

READ AND SAVE THESE INSTRUCTIONS

VAPOR-LOGIC[®]

MICROPROCESSOR BASED HUMIDIFIER CONTROL SYSTEM

**Installation, Start-Up,
and Operations Manual**

**For Toll-free Customer Support,
Call: 1-800-328-4447**

DRISTEEM[®]
HUMIDIFIER COMPANY

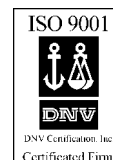

TABLE OF CONTENTS

TO THE PURCHASER AND THE INSTALLER

Thank you for purchasing the VAPOR-LOGIC® microprocessor based humidifier control system. We have designed and developed this system to give you total satisfaction and many years of trouble-free service. Proper installation and operating practices will assure you of achieving that objective. We urge you to become familiar with the contents of this manual.

DRI-STEEM Humidifier Company

VAPOR-LOGIC Program Code Nomenclature	3
VAPOR-LOGIC® Microprocessor Installation Checklist	4
Placement and Wiring of Sensing Devices	
Sensing Device Placement	5
Control Precautions	5
Humidistats and Transmitters	6
Placement and Wiring of Optional Sensing Devices	7
Proper Wiring Procedures	8
VAPOR-LOGIC Control Cabinet Installation	9
VAPOR-LOGIC Key Pad / Digital Display Installation	10
Start-up Instructions	11
Start-up Trouble-Shooting Checklist	12
Introduction to VAPOR-LOGIC	13
VAPOR-LOGIC Control Board Connections	14
VAPOR-LOGIC Control Board Operation	16
VAPOR-LOGIC Function Keys Self-Test Procedure	18
VAPOR-LOGIC Key Pad / Digital Display Operation	20
Key Pad Description	20
Accessing VAPOR-LOGIC Sub-Menu Information	21
Sub-Menu Instructions for V2.04 Firmware	22
Activating Digital Meter for V2.04 Firmware	23
VAPOR-LOGIC Control Schemes	24
VAPOR-LOGIC P.I.D. Control Loop: Terminology	27
VAPOR-LOGIC P.I.D. Control Loop: Tuning	29
Main Menu / Auto Scroll Information	31
Digital Display Read Outs	33
Digital Display / Key Pad Trouble Shooting Guide	34
Fault Indicator Codes	36
Trouble-Shooting Guide	40
Replacement Parts	47
Glossary	48
Notes	50
Two-Year Limited Warranty	51

VAPOR-LOGIC® PROGRAM CODE NOMENCLATURE

An eleven digit VAPOR-LOGIC program code appears on the front of the control cabinet and on the wiring diagram inside of the control cabinet. The program code specifies the parameters necessary for the VAPOR-LOGIC microprocessor to control your system. An explanation of the program code is detailed below.

VAPOR-LOGIC PROGRAM CODE

- A. VAPOR-LOGIC board classification:
 Single tank system = 1
 Double tank system = 2
 Triple tank system = 3
 Quad tank system = 4
- B. Digital Display/Key Pad features:
 N = None L = Local
 B = Local & Remote
- C. Type of outputs (0-4) _____
 0 = Steam valve/ 100% SCR Multiple Units
 1 = One heater 3 = Three heater
 2 = Two heater 4 = Four heater
- D. Output size _____
 Steam valve = 00/ 100% SCR Multiple Units
 2KW Heater = 02 9KW Heater = 09
 3KW Heater = 03 10KW Heater = 10
 4KW Heater = 04 12KW Heater = 12
 5KW Heater = 05 14KW Heater = 14
 6KW Heater = 06 16KW Heater = 16
 7KW Heater = 07 18KW Heater = 18
 8KW Heater = 08 20KW Heater = 20
 25KW Heater = 25
- E. Type of water level control:
 VSDI w/manual drain = D
 Probe w/manual drain = M
 Probe w/auto drain = A
 EOS/DI drain = E
- F. Operating mode:
 Single staged = 1 Steam Valve (ANALOG) = 6
 Externally staged = 2 TP/PID = 7
 Zone valve = 3 SCR/PID = 8
 TP = 4 SV/PID = 9
 SCR (DIGITAL) = 5
- G. VAV options:
 V = Option
 O = Otherwise
- H. Temp. comp. options:
 T = Option
 O = Otherwise
- I. Aquastat options:
 A = Option
 O = Otherwise
- J. Type of humidity sensing device:
 N = None, for off-on
 C = 0-135 ohms humidistat
 D = 6-9 VDC humidistat
 E = 4-20 MA humidistat
 X = 4-20 MA transmitter
 S = Special

Example: Code number: 1L110A7000X

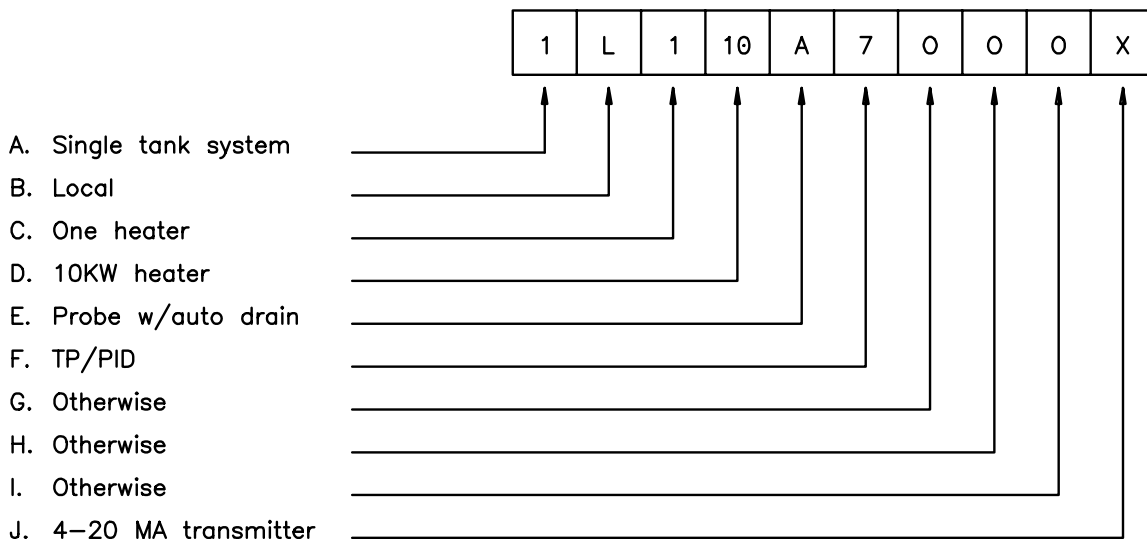

Code number for typical VAPOR-LOGIC slave control board 1N110A7000N
 Revised 5/10/96

VAPOR-LOGIC® INSTALLATION CHECKLIST

IMPORTANT: Before installing your VAPOR-LOGIC control system, review this checklist to ensure proper installation of the product. Failure to follow the recommendations listed below could result in failure or damage to the humidifier or microprocessor.

- 1. Read this manual and information before starting.
- 2. Wiring diagram and information are located inside the control cabinet door. All information should remain with the control cabinet after installation.
- 3. Locate the control cabinet so that the wire length from the **control cabinet to the humidifier is 50 feet or less.**
- 4. Connect an approved electric earth ground to the earth ground lug in the control cabinet.
- 5. Never route the low voltage field control wires near the line voltage section of the control cabinet or in the same conduit as line voltage wires.
- 6. Never use shielded cable for water level probe wiring.
- 7. For proper humidifier operation, the heater/machine ground lug in the junction box must be attached to the sub-panel machine ground lug with the appropriate wire, sized per equipment grounding section of National Electric Code.
- 8. All humidity and temperature sensor wiring be a 2-wire, #18 gauge shield plenum non-conduit-rated cable with drain wire. (Belden Company cable #88760 or equivalent; see wiring diagram for appropriate connections.)
- 9. A "shield" grounding lug is provided on the control cabinet sub-panel to ground the cable shielding. **Do not ground shield at sensor end.**
- 10. Digital Display Module/(key pad) Installation Precautions
 - a. Do not locate key pad inside control cabinet.
 - b. Route modular cable within control cabinet separated from line voltage circuits.
 - c. Do not connect or disconnect the modular cable while power is applied to the VAPOR-LOGIC board.
- 11. **Verify that VAPOR-LOGIC program code** which is detailed on page 3 of this manual matches field requirements.
- 12. Follow the recommended control cabinet field conduit knockout locations. (See diagram 4-1.)

Figure 4-1: Control Cabinet

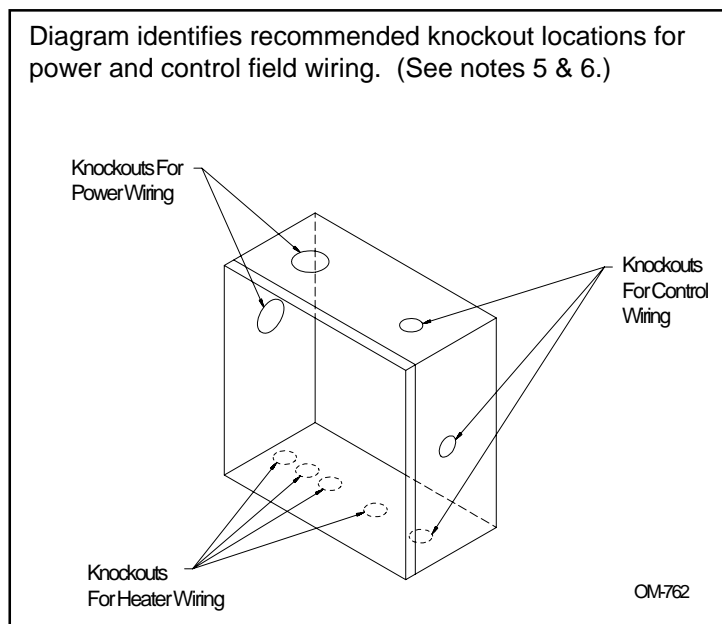

CAUTION - When providing holes and knockouts in the control cabinet, protect all internal components from debris and vacuum out cabinet when finished. Failure to comply with this warning may damage sensitive electronic components and void the DRI-STEEM warranty.

PLACEMENT OF SENSING DEVICES

Sensing Device Placement

The location of the humidity sensing devices is very important to achieve accurate humidity control. A drawing of a typical small air handling system is shown below (figure 5-1). For the best control, place the humidity sensing device in the center of room, or just inside of the return air duct (location "A"). This will provide the least amount of variation caused by air flow patterns and room temperature. Placement of the duct humidity sensing device within outlet of air handler (location "D") is ideal for duct high limit control, but the actual placement must be downstream from dispersion tubes a sufficient distance to ensure steam absorption in room and ducts is also very important to improve control of relative humidity.

Control Precautions

Unsatisfactory results from humidifying control may involve more than just the controller's capability to control the system. Other factors that plays an important role in overall system control are:

- Size of the humidification system relative to load.
- Overall system dynamics associated with moisture migration time lags.
- Accuracy of humidistats and humidity transmitters and their location.
- Dry bulb temperature accuracy in space or duct.
- Velocities and air flow patterns in ducts and space environments.
- Electrical noise or interference.

Figure 5-1: Recommended Placement of Humidistat Control or Humidity and Temperature Transmitters

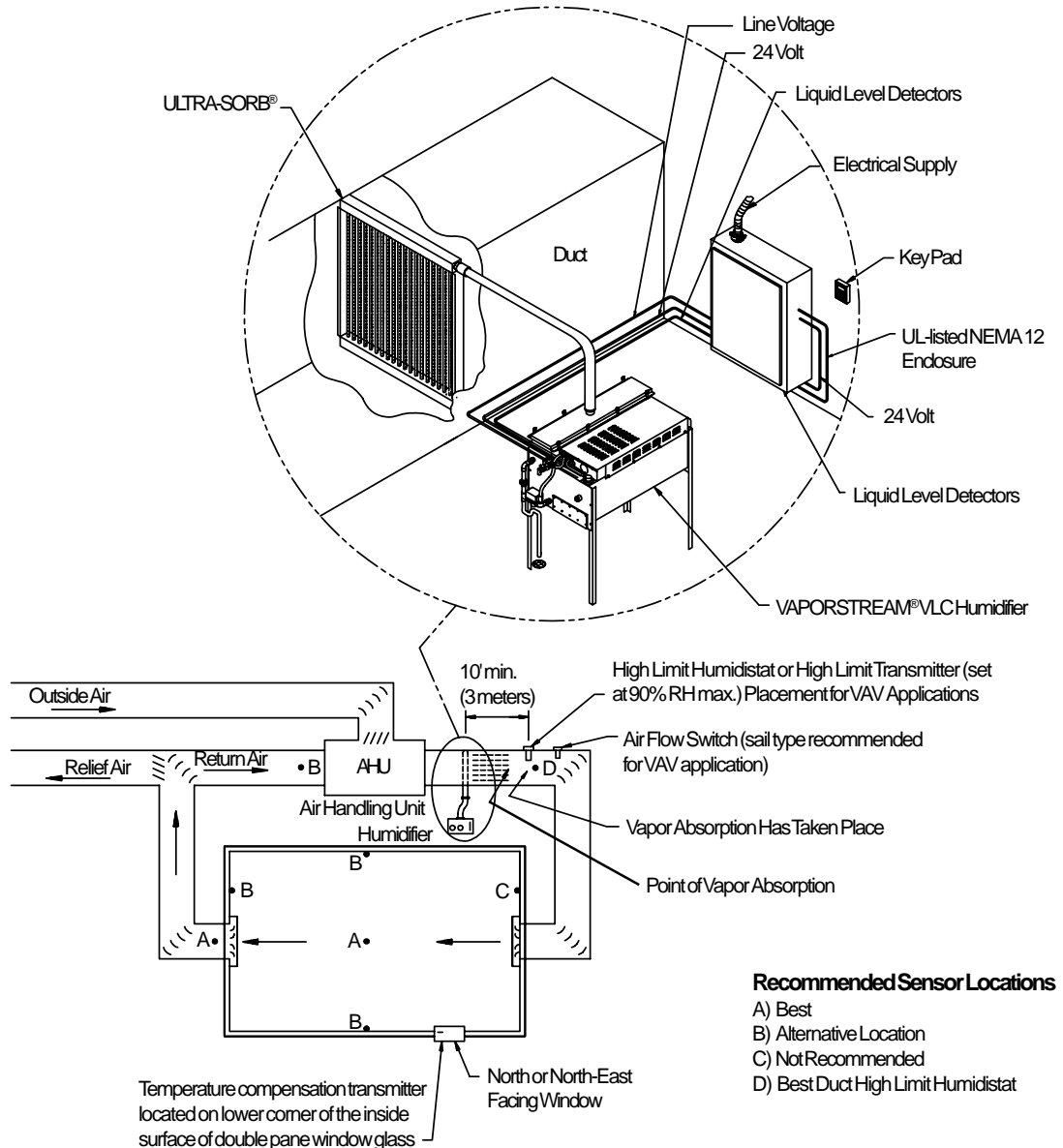

WIRING OF SENSING DEVICES

Wiring On-Off Humidistats

DRI-STEEM may provide three types of on-off controls: wall mounted, duct mounted or pneumatic/electric relay. The wiring diagram (found on the inside of the humidifier control cabinet) will show proper wiring for these controls.

Wiring Modulating Humidistats

The standard modulating humidistat controllers DRI-STEEM provides either duct or wall mounted humidistats.

The humidistats are powered by 21 VDC supply provided by the VAPOR-LOGIC® control board. A 6-9 VDC control signal is returned to provide the modulating function.

Using a pneumatic modulating signal, DRI-STEEM may provide a transducer to accept a 3-20 psi pneumatic input range.

A two-wire 0-135 ohm humidistat is also adaptable to the VAPOR-LOGIC control board.

Wiring Modulating Humidity or Temperature Transmitters

All transmitters provided by DRI-STEEM are two-wire devices. (See your wiring diagram for proper connections.) The humidity transmitters have a range of 0-100% RH with an output of 4-20 mA. The temperature transmitter has a range of -20° to 160°F with a 4-20 mA output.

Figure 6-1: Example of Proper Shielding Techniques When Connecting Humidity or Temperature Devices to VAPOR-LOGIC Control Inputs

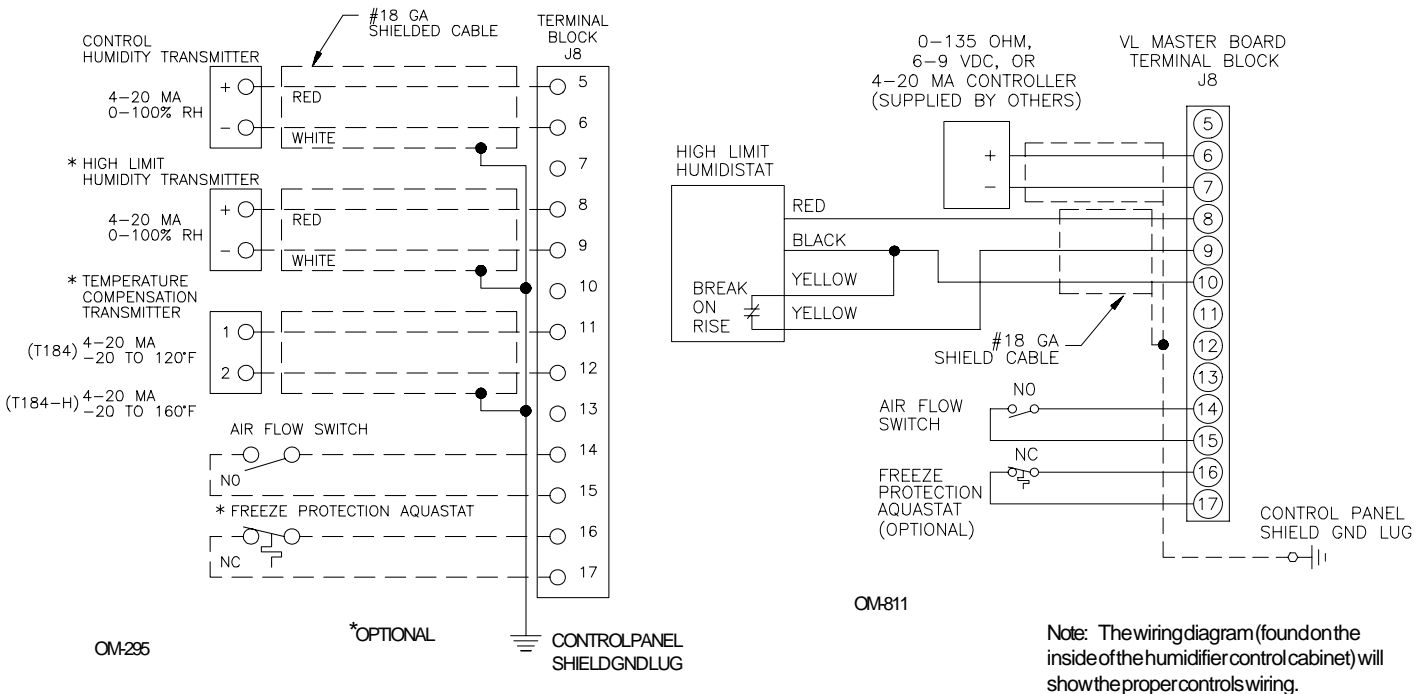

Note: The wiring diagram (found on the inside of the humidifier control cabinet) will show the proper controls wiring.

Important: Consult control cabinet wiring diagram. Control changes require wiring and programming changes.

PLACEMENT AND WIRING OF OPTIONAL SENSING DEVICES

OPTION: Variable Air Volume (VAV) (Shielded cable recommended, see note.)

When the VAV control option is requested, DRI-STEEM will provide, in addition to the room control transmitter, a duct mounted humidity transmitter (4-20 mA output over 0-100% RH range).

The modulating high limit transmitter signal operates in conjunction with the "Room or Duct" controlling transmitter signal through the VAPOR-LOGIC control system to prevent over humidification in the duct work. VAPOR-LOGIC will start lowering the humidifier output when the duct relative humidity is within 6 percent of the duct high limit set point.

When this occurs, the digital key pad will display the message "VAV Output Limit". If necessary, the reduction of the humidifier output will continue until maximum high limit set point has been reached, shutting off the humidifier completely.

When the high relative humidity starts to decrease in the duct, VAPOR-LOGIC will slowly start to increase the production of steam vapor. When the duct relative humidity decreases to a point greater than 6 percent below the duct high limit set point, the control transmitter will be restored as the primary controller and the key pad will remove the "VAV Output Limit" text, returning the control system to normal operation.

Figure 7-1: Shielded Cable

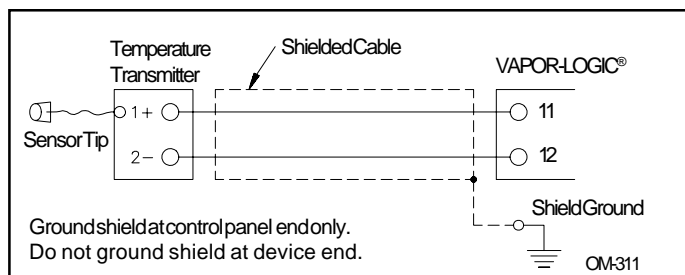

OPTION: Cold Snap RH Offset (Shielded cable recommended, see note). When selected as an option, DRI-STEEM provides a cold snap temperature transmitter.

The cold snap temperature transmitter continually monitors the interior window glass temperature and transmits this temperature to VAPOR-LOGIC. VAPOR-LOGIC then compares the glass temperature to the desired RH set point in the humidified area and calculates the dew point (°F) for the space. VAPOR-LOGIC will lower (offset) the desired RH set point to a safe condition, where condensation will not

form on windows. The key pad will display the amount of offset that has taken place, "OFFSET RH=___%". As the interior window glass temperature increases, VAPOR-LOGIC will reduce the offset and restore system control to the normal RH set point for the space.

The transmitter provided with VAPOR-LOGIC firmware V2.01 and higher is calibrated for -20° F to 160° F with output from 4-20 mA. A temperature reading of 70° F should produce a measurement of 12 mA.

Note: DRI-STEEM recommends using an #18 gauge plenum rated shielded cable for transmitter wiring and grounding shield at a common point in the control cabinet (see figure 7-1).

Cold Snap Transmitter Placement (See figure 7-2.)

1. Position the cold snap transmitter control box on a wall adjacent to window frame.
2. Place flat surface of temperature sensor tip on lower corner of glass surface.
3. Temporarily hold the sensor tip in place with strips of masking tape.
4. Apply a small amount of clear RTV silicone adhesive over and around the sensor tip (making sure the sensor tip is in contact with the window glass).
5. After adhesive has cured, remove masking tape.

Figure 7-2: Cold Snap Transmitter Placement

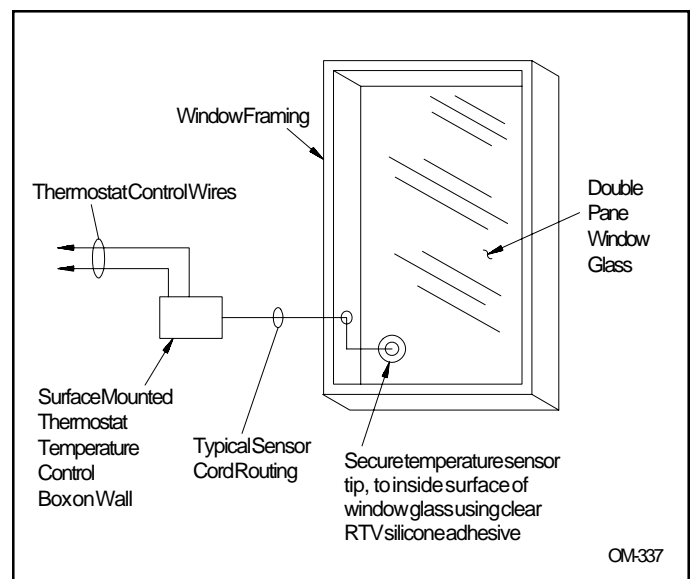

PROPER WIRING PROCEDURES

Electrical noise can produce undesirable effects on the electronic control circuits that can affect controllability. Electrical noise is generated by electrical equipment, such as resistive loads, electric motors, solenoid coils, welding machinery, fluorescent light circuits, etc. The electrical noise or interference generated from these sources (and the effects on controllers) is very difficult to define, but most common symptoms are erratic operation or intermittent problems.

However, most noise problems can be prevented by using wiring practices and techniques which prevent coupling or inducing of electrical interference into control circuits. Some simple wiring practices associated with DRI-STEEM humidifier equipment should minimize interaction of noise and controls:

- Humidifier and control cabinets must be connected to a code approved earth ground.
- When routing electrical wiring inside the control cabinet, separate the line voltage wiring from low voltage control circuit wiring.
- Use separate electrical conduits for line and low voltage control wiring from the humidifier to humidity sensors, airflow switches, etc.

- Do not use chassis or safety grounds as current carrying commons. No safety grounds should ever be used as a conductor or neutral to return circuit current.
- The preferred method of external electrical connections to humidistats, room/duct humidity and temperature transmitters, and control signal input connections from building control systems is minimum #18 gauge plenum rated wire cable of twisted pair type, BELDEN #88760, including cable shielding and drain wire for grounding.
- All grounding of shielded cable connections should be returned to the control cabinet and tied to the shielded cable ground lug. Do not ground shield at the device end.
- **IMPORTANT: Locate the control cabinet so that wire lengths are 50 feet or less to the humidifier.**
- Probe and low water cut off wiring must be individual 18 gauge stranded wire run in conduit (see figure 8-1). Do not use shielded cable for probe wiring.

Figure 8-1: Probe Wiring

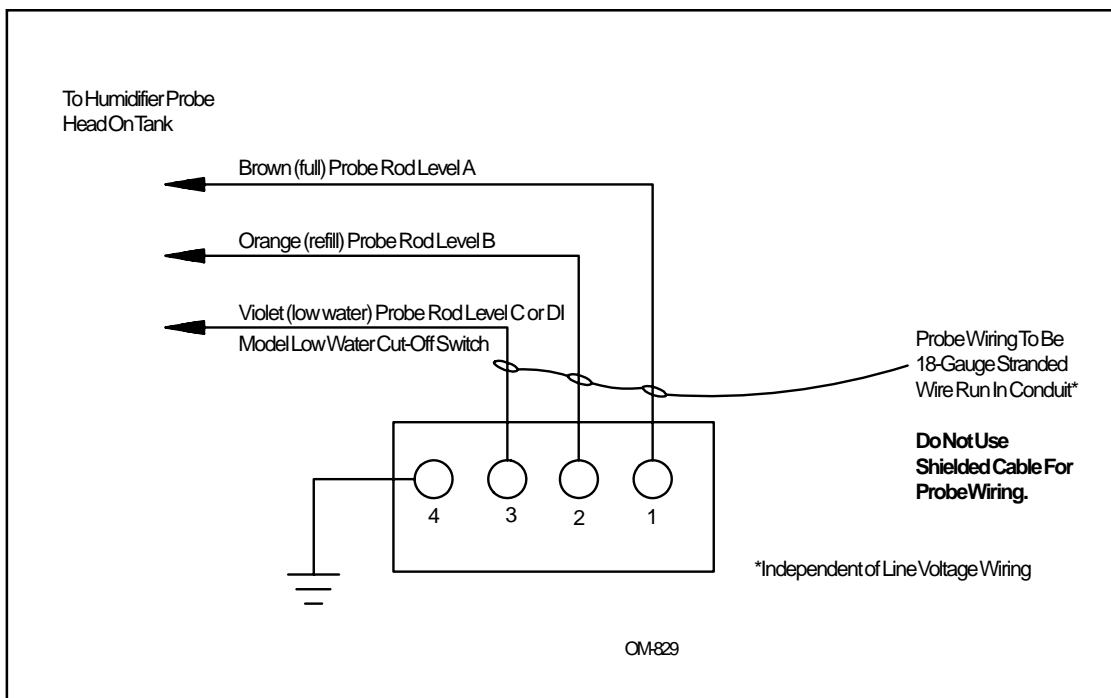

VAPOR-LOGIC® CONTROL CABINET INSTALLATION

The VAPOR-LOGIC control board is shipped mounted with all internal wiring completed within a control cabinet. All software has been custom programmed into your VAPOR-LOGIC system according to the original order requirements. Refer to the VAPOR-LOGIC control board drawing for detail of the board and connection points. (See figure 13-1 on page 13.)

The VAPOR-LOGIC control board should always be wired following local and national electric codes. VAPOR-LOGIC is powered by a low voltage class 2 control transformer. The transformer provides a 24 VAC supply, and is protected by an integral manual reset circuit breaker.

All humidifier power wiring is represented on the humidifier wiring diagram.* Follow field wire torque requirements shown on the humidifier wiring diagram when connecting the power and control wiring inside the humidifier control cabinet. Additional precautions about VAPOR-LOGIC control board connections are:

- Use 1/8" straight blade screwdriver on VAPOR-LOGIC control board terminal blocks.
- DRI-STEEM recommends a single #18 gauge pre-tinned wire in each terminal at the VAPOR-LOGIC terminal block. Torque to 5 inch pounds.
- When terminating multiple wires to VAPOR-LOGIC control board terminal blocks, DRI-STEEM recommends securing the multiple wires and one additional wire with appropriately sized wire nut. Use the single additional wire's opposite end to connect to the VAPOR-LOGIC terminal block.
- Never run control system wires bundled with, or in the same conduit as, power wires.
- Pick a location that will allow for easy access to the control cabinet and internal electrical components. Mount control cabinet using the mounting tabs.

IMPORTANT: Locate the control cabinet so that wire lengths are 50 feet or less to the humidifier.

***A wiring diagram and installation guide is attached to the inside of control cabinet door. All instructions should remain with the control cabinet after installation.**

VAPOR-LOGIC® KEY PAD / DIGITAL DISPLAY INSTALLATION

Installing Modular Cable

Important: To properly identify the second remote key pad to the master VAPOR-LOGIC microprocessor, a shunt connection is provided and installed by DRI-STEEM across a connector pin. Refer to the digital module printed circuit board in figure 18-1 or 18-2 on page 18 to confirm location and placement.

Align the front section over the two top finger hooks on the back section, rotate down, and snap front section onto the back section. Route modular cable as needed to control cabinet and drill necessary hole for appropriate cable strain relief fitting. **Note: Do not wrap cable around the key pad.** When routing modular cable inside the control cabinet, route cable away from all power wiring and connect the male modular plug into either VAPOR-LOGIC printed circuit board-mounted female modular receptacles, J1 or J2. Push male plug in until you hear a “click.” (The cable may be plugged into either J1 or J2 on the keypad as well.) The 4-wire cable provides the DC power to the digital module and completes the RS485 type digital communication between the local and/or remote modules and the VAPOR-LOGIC control board.

Caution: When fabricating longer modular cables, electrical polarity is very important in securing the type RJ11 male plugs to cable. Both ends of cable polarity connections must be identical. (See figure 10-1.)

Installing the Key Pad

Do not locate the module inside the control cabinet. The hardware is pre-mounted in a thermoplastic case with front access to the digital display and key pad. DRI-STEEM also provides 26-gauge, 4-wire pre-connected modular cables with male modular plugs attached. The modular plugs are 6-position 4-wire type RJ11 arrangement. Position case in a convenient location for easy access. **The ambient temperature range for modules is 32° to 122°F. Exceeding these limits will result in a poor reading, or no reading at all.**

The digital display key pad case is fabricated in two sections; light pressure at the base of the back of the case will separate the two sections. The front half includes the electronic display module control board and key pad, which are secured by four screws. DRI-STEEM

recommends the back section of enclosure be secured to a standard electrical switch box with modular cable routed out the rear of the case. (See figure 10-2.) A second choice is a direct mount to any surface using field supplied screws. Route modular cable out the bottom of enclosure. Because of various mounting possibilities, first provide the necessary clearance holes for the hardware you are using by opening the two pilot mounting holes on the back of enclosure. Mount the back of enclosure to a flat surface and secure as necessary.

Caution: Overtightening will distort the back of the case.

Figure 10-1: Cable Polarity Connections

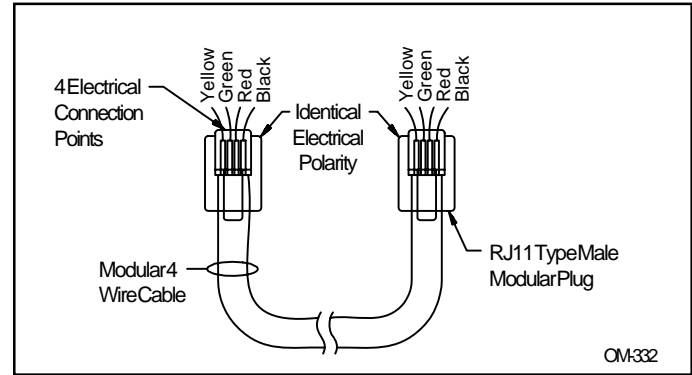
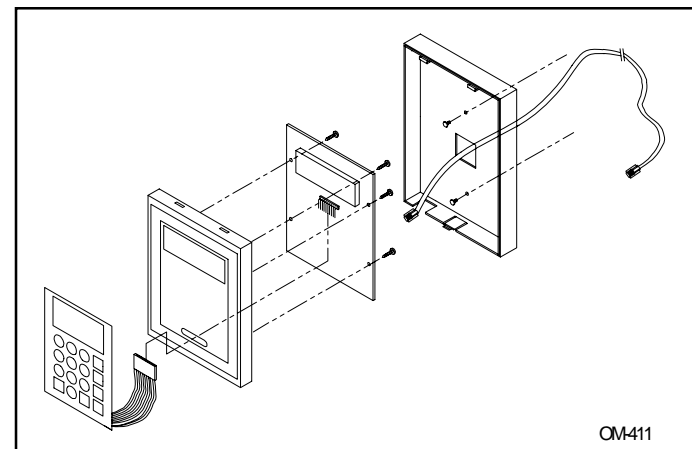

Figure 10-2: Exploded View of Key Pad/Digital Display



START-UP INSTRUCTIONS

1. Confirm that the control signal being connected to the VAPOR-LOGIC® system is compatible with the VAPOR-LOGIC program. Identify the VAPOR-LOGIC program code on the wiring diagram or on the outside of control cabinet door. Refer to the VAPOR-LOGIC Manual to decipher the code using the nomenclature description on page 3.
2. Confirm all wiring is correct per wiring diagram.
3. Confirm that proper grounding and an approved earth ground are provided.
4. Confirm J9, J10, J11 shunt connectors on VAPOR-LOGIC board are in their correct position per wiring diagram. See page 13 for the physical locations.
5. Confirm four position slide switch on VAPOR-LOGIC board is in "AUTO" position.
6. Confirm that the digital key pad is mounted on the outside of the control cabinet with modular cable routed away from the high voltage circuits and connected to either J1 or J2 female connector on control board.
7. Turn water supply on, confirm drain valve is closed.
8. Turn power on, the key pad will display the introduction of "VAPOR-LOGIC", transfer into **INITIALIZING**, and the enter into AUTO mode. In AUTO mode, the system will continuously scroll system operations status (see pages 31 and 32).
9. In normal operation, the red LED lamp on VAPOR-LOGIC board will blink off-on like a heart beat. (In fault mode, the red LED lamp will blink a pulse code.)
10. System will initiate filling of the tank with water, key pad will display "low water" as part of auto scroll text.
11. Airflow switch input must be closed.
12. High limit humidistat input must be closed or Variable Air Volume (VAV) control system high limit transmitter must be connected.
13. If aquastat option is furnished, connections to terminals #16 and #17 are necessary.
14. With sufficient water in tank, (on some newer models a green LED lamp on the control board will be illuminated), airflow switch closed, high limit humidistat closed, and a call for humidity, the heater outputs will be energized. If the tank does not contain water and the heaters are energized by the VAPOR-LOGIC control system, a serious failure will result. Immediately remove power from the system and verify that all wiring is done per the wiring instructions in this manual and the unit wiring diagram.
15. During normal operation, the key pad will display auto scroll features of humidifier operating status. See pages 31 and 32 for descriptions.
16. To change any of the operating parameters, depress the "MODE" key on key pad to activate the VAPOR-LOGIC main menu. Use the up-down arrow keys to select a main menu item. Press ENT key to allow you to change the operating parameters. Refer to pages 20 and 21 for a complete description and pages 31 and 32 for all the other possible main menu items.
17. If necessary to re-start VAPOR-LOGIC, depress the reset button on the electrical sub-panel, hold for a few seconds, then release.

START-UP TROUBLE-SHOOTING CHECK LIST

When starting up your system, please refer to the following:

- 1. Verify that wiring is done per instructions in this manual and the unit wiring diagram.
- 2. Make sure the key pad is not inside the control cabinet.
- 3. Check water level control voltages, the reading should be 2.5 VAC without water; 0 VAC with water from ground (pin 4-J12) to probe inputs (pins 1, 2 & 3-J12).
- 4. Check the throttling range on the Main Menu of the keypad (default is 11%).
- 5. Check cycle setting on the Main Menu of the keypad (default is 60 seconds; default is 4 seconds with SCR).
- 6. Check delay setting on the Main Menu of the keypad (default is 20 seconds).
- 7. Check time to auto drain (default is 50 hours).
- 8. Check drain duration (default is 8 minutes).
- 9. Check drain and flush sequence (default is 8 minutes).
- 10. Check RH setting.
- 11. Check control signal.
- 12. Perform test cycle of the system.
- 13. Check amp draw of heater(s); refer to wiring diagram for proper rating.

If you experience difficulties, have the above information available with the model number(s) of the humidifier, the VAPOR-LOGIC program code, the VAPOR-LOGIC board revision, and the VAPOR-LOGIC software revision and call DRI-STEEM for help.

Note: Your humidification system may not have all of the options listed above. If an item does not appear, skip to the next item and continue the process.

INTRODUCTION TO VAPOR-LOGIC

This section explains the operation, installation, and use of the VAPOR-LOGIC® controller.

VAPOR-LOGIC is a custom microprocessor based humidifier control system developed to be compatible with the DRI-STEEM humidifiers. The versatile microprocessor firmware is configured to meet the needs of a multitude of humidifier applications. The advanced technology of VAPOR-LOGIC is paired with simple operating procedures to make the control system easy to use.

VAPOR-LOGIC features include a self-diagnostic test during initialization, end of season auto-drain, and a full-function digital display key pad which allows you to monitor and adjust humidifier performance parameters as necessary. VAPOR-LOGIC also offers a variety of control modes:

- On-off operating mode controls single or multiple electric staged outputs and multiple zone valve humidification applications.
Expected accuracies: $\pm 5-7\%$ RH

- Time proportioning modulation function controls humidifier outputs via cyclic actions on electrical contactors or a modulated pulsed signal to our solid state zero cross-fired SCR power controllers.

Expected accuracies:
 - Contactor Action: $\pm 2-4\%$ RH
 - SCR Action: $\pm 1-3\%$ RH

- Proportional Action controls modulating steam or hot water valves by providing a linear analog D.C. signal voltage to the valve motors. (For STS or LTS humidifiers.)
Expected Accuracies: $\pm 2-5\%$ RH

- VAPOR-LOGIC controls with a P.I.D. (proportional, integral, derivative) function.
Expected accuracies: $\pm 1-3\%$ RH

VAPOR-LOGIC can control humidifier systems with up to four steam generators.

Figure 13-1: VAPOR-LOGIC Printed Circuit Board

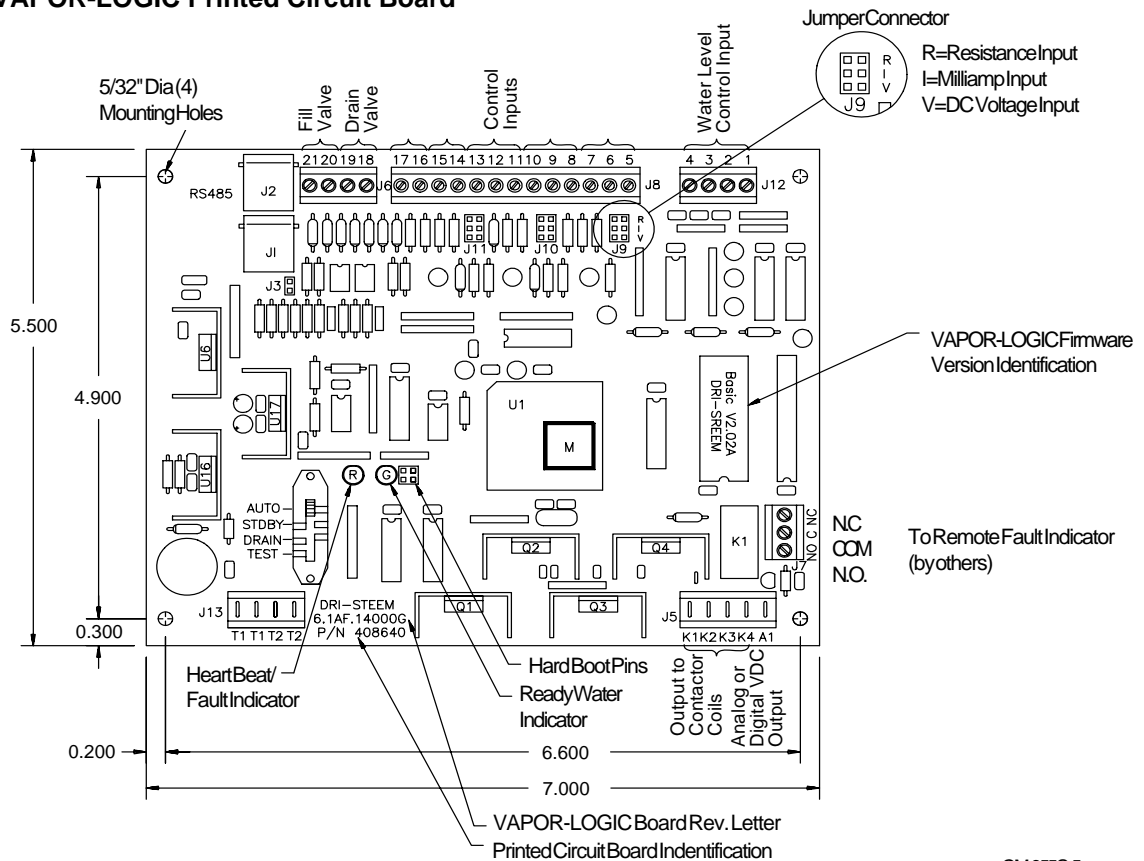

OM-355G-5

VAPOR-LOGIC® CONTROL BOARD CONNECTIONS

Control Board Connections (See figure 13-1 on page 13.)

J1, J2 Two parallel wired type RJ11 (6 position, 4 wire) female modular jack connections for supply voltage and VAPOR-LOGIC communication to digital key pad. When multiple humidifier systems are combined using RS485 communication format, J1 and J2 also provide communication to additional VAPOR-LOGIC control slave boards.

J3 End of line communication terminator pins require a jumper connector across J3 pins when VAPOR-LOGIC supports a "Remote" digital key pad.

J5 Wire terminal connection supplies output signal to electric contactor coils and/or modulating SCR control.

- Terminal K1: 24 VAC signal to heater number 1 contactor
- Terminal K2: 24 VAC signal to heater number 2 contactor
- Terminal K3: 24 VAC signal to heater number 3 contactor
- Terminal K4: 24 VAC signal to heater number 4 contactor
- Terminal A1: A time proportioned positive polarity 0-15 VDC signal to the input of a slave SCR power controller, 0-15 VDC to the input steam or hot water valve. The negative polarity from SCR is connected to terminal #4 of wire connector J12.

J6 Wire terminal connector supplies 24 VAC voltage with terminals 20 and 21 to the fill valve and with terminals 18 and 19 to the drain valve.

J7 Wire terminal connection allows for remote fault indication. Relay closure is provided. (1AMP MAX)

J8 Wire terminal connector receives the necessary input signal from external device:

- a. Humidity Control uses Control Input 1.
- Terminal 5: Positive polarity 21 VDC supply max. 25 mA
 - Terminal 6: Control signal
 - Terminal 7: Signal ground
- Input selector pin J9 configures Input 1.

- b. Optional high limit humidity control uses Control Input 2.
- Terminal 8: Positive polarity 21 VDC supply max. 25 mA
 - Terminal 9: Control signal
 - Terminal 10: Signal ground
- Input selector pin J10 configures Input 2.

- c. Optional temperature compensation sensor uses Control Input 3.
- Terminal 11: Positive polarity 21 VDC supply max. 25 mA
 - Terminal 12: Control Signal
 - Terminal 13: Signal ground
- Input selector pin J11 configures Input 3.

- d. Air flow proving switch uses optically isolated Control Input 4. Terminal 14 supplies 24 VAC to proving switch circuit, SPST, which closes when air flow is present. Terminal 15 is the return connection from the proving switch into the VAPOR-LOGIC control.

- e. Optional freeze protection aquastat uses optically isolated Control Input 5. Terminal 16 supplies 24 VAC to aquastat, SPST, which closes when aquastat calls for heat. Adjustable temperature range 40°-180°F, but 40°F setting preferred. Terminal 17 is return connection from aquastat into VAPOR-LOGIC control.

J9 Selection pins control the configuration of the type of input control into Control Input 1 (Terminals 5 through 7) of wire terminal connector J8.

- a. R = Resistance 0-135 ohms range
- used with on-off humidistats, staging switches, PE switches
 - used with analog 0-135 ohm input device (pneumatic transducer or humidistat)

- b. I = Milliamp 4-20 mA range
- used with any humidity sensor with output 4-20 mA
 - used with any computer or energy management system with 4-20 mA output
 - internal resistance 250 ohms, terminal #6 proportional signal, terminal #7 signal ground

VAPOR-LOGIC® CONTROL BOARD CONNECTIONS

- c. V = Volts D.C. 1-15 volt range (6-9 VDC control span)
- used with any control humidistat 0-15 VDC
 - Terminal #5 provides positive 21 VDC supply, terminal #6 proportional signal, terminal #7 signal ground

J10 Identical to J9 input selector pins except configures Control Input 2 (Terminals 8 through 10) of wire terminal connector J8. Typically used for high limit humidistat.

J11 Identical to J9 input selector pins except configures Control Input 3 (Terminals 11 through 13) of wire terminal connector J8. Typically used for on-off staging or 4-20 mA input for optional temperature compensation.

Important: All connection diagrams show connector shunts on J9, J10 and J11. The connector shunts and appropriate computer software have been selected by DRI-STEEM based on original customer orders. **Field changing the input connector shunts will require software modification.**

J12 Connector receives necessary continuity input signals from water detection devices.

- a. Probe system water level detection
- Terminal 1 detects maximum water level from top probe rod and brown plug wire.
 - Terminal 2 detects water level at refill point from middle probe rod and orange plug wire.
 - Terminal 3 detects water level at its lowest point from lower probe rod and purple plug wire.
 - Terminal 4 is the common return path for all water detection rods from the humidifier tank ground back to VAPOR-LOGIC control.
- b. DI system detection
- Terminals 1 & 2 are not used.
 - Terminal 3 is connected to the humidifier tank low water float switch (normally open).
 - Terminal 4 is the return signal from float switch to VAPOR-LOGIC control.

J13 Wire terminal connector supplies 24 VAC to power the VAPOR-LOGIC control board.

- Double terminal T1 - 24 VAC +, 7 VA maximum load.
- Double terminal T2 - 24 VAC-comm.

VAPOR-LOGIC® CONTROL BOARD OPERATION

Figure 16-1: Four Position Slide Switch

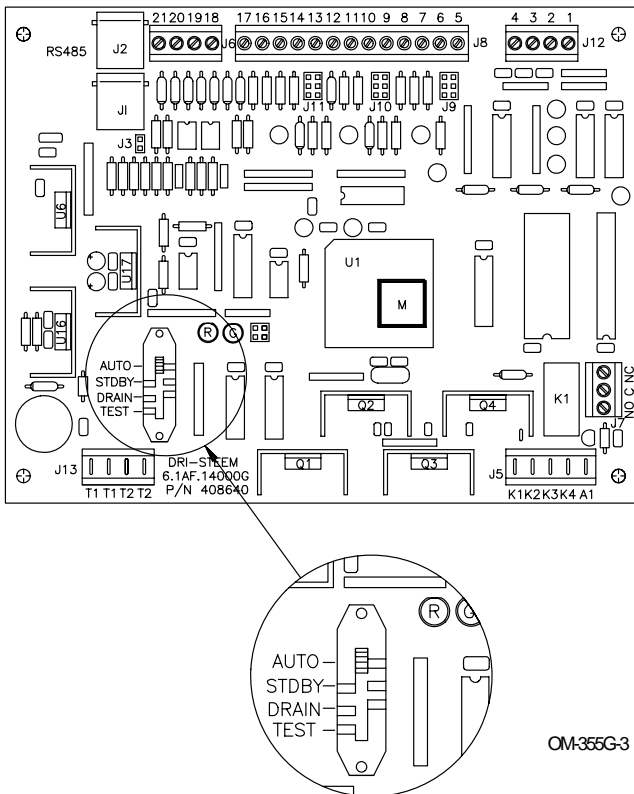

AUTO When the slide switch is in “AUTO” position, the humidifier is in full operation, maintaining the water level and capable of generating steam upon a call for humidity.

STDBY When the slide switch is in the “STDBY” (stand-by) position, it interrupts the control system and turns the humidifier off. “STDBY” is used for regular humidifier inspection. (In a multiple tank system, only the board placed in "STDBY" will shut down, the other boards will remain operational.)

DRAIN When the slide switch is in the “DRAIN” position, it deactivates the heating function and the fill valve. The electric drain valve is then activated, and the water drains from the evaporating chamber. The drain valve also has a manual drain lever. If the humidifier needs to be drained during an electrical power outage, this function can be used. (A “DI” model humidifier will have a “DRAIN” mode only with special option End of Season Drain.) (In a multiple tank system, only the board placed in "DRAIN" will drain, the other boards will remain operational.)

TEST When the slide switch is moved to the “TEST” position, it activates the test cycle. All electrical devices that are on when the test cycle is initiated are deactivated. During this cycle the fill valve and all electrical contactors will be cycled on-off individually. The drain valve will then be held open for 30 seconds. At the completion of the test cycle, VAPOR-LOGIC will revert to stand-by mode. (The “TEST” mode is not functional on Slave Boards.)

On-Board Fault Indicator Light

The indicator light has dual functions. One function is to present a continuous heartbeat (cycling on-off), indicating a normal operation control by the VAPOR-LOGIC micro-processor. The second function is for indication of a FAULT condition, done by changing from the normal heartbeat to a series of long and short pulses. The different pulse patterns indicate the type of fault detected. The chart of fault code descriptions can be found on pages 36-39.

To have an indication of a humidifier fault at a remote location, VAPOR-LOGIC has a pre-wired fault relay (SPDT contact arrangement) wired to the control terminal block J7. This will allow for field connection of a low voltage (24 VAC, 1 amp max.) circuit for remote indication that a fault condition exists. The remote fault indication does not indicate which fault has occurred, only that VAPOR-LOGIC has detected a fault. You must return to the humidifier VAPOR-LOGIC control board to read the on-board fault indicator light code in order to determine what type of fault was detected.

On-Board Ready Water Indicator Light

When the humidifier has sufficient water in the evaporating tank the "Green" LED light on the control board will be illuminated.

VAPOR-LOGIC® CONTROL BOARD OPERATION

Auto Drain Sequence

VAPOR-LOGIC is pre-programmed to enter an automatic drain, flush, and refill cycle to help keep mineral concentrations in the tank to a minimum, based upon the actual time the humidifier has produced steam. VAPOR-LOGIC is factory-set for a 50 hour (accumulated "ON" time) drain interval, with 8 minute drain and 8 minute flush durations. When VAPOR-LOGIC initiates the auto drain sequence, all energized heaters are turned off. The drain valve is then opened to allow the tank to drain. The drain valve remains open during the flush sequence for drainage while the fill valve is open. At the completion of the flush cycle, the drain valve closes, allowing the fill valve to refill the tank. The VAPOR-LOGIC timers are then reset and the humidifier returns to normal "AUTO" operation. For multiple tank systems, only one tank at a time goes into the Auto Drain Sequence in order to keep as much capacity available as possible.

End of Season Drain

If there is not a call for humidity for a 72 hour period, (72 hours option on DI humidifiers) VAPOR-LOGIC automatically drains the evaporating chamber. The drain valve is held open for one hour. The humidifier then switches into "STDBY" mode until there is a call for humidity, at which time VAPOR-LOGIC automatically refills the evaporating chamber and resumes normal operation.

Probe System

A conductivity probe system allows VAPOR-LOGIC to control water levels for optimum operating efficiency. The three-probe system is monitored by the VAPOR-LOGIC control, which performs all the necessary logic

Figure 17-2: Conductivity Probe System

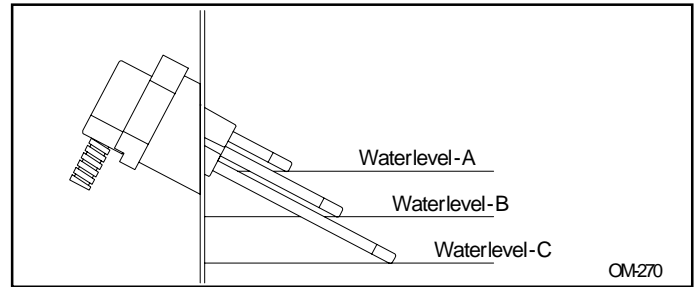

and timing functions to provide total water level control and safety shutdown.

VAPOR-LOGIC automatically maintains the water level between the upper two probes A and B. When the water level falls below probe B, the fill valve is opened until the water level reaches the upper probe A. A minimum two second delay is incorporated in the skim time software to ensure that turbulence does not cause an incomplete fill. Each time the fill valve is energized, the probe system is tested by the VAPOR-LOGIC system. If the signal from the probe assembly is beginning to deteriorate, the message "REPLACE PROBES" will appear. Once the probe system has reached its maximum usable life, the humidifier will shut down and the message "PROBE FAULT" will appear (VAPOR-LOGIC firmware V2.04 and higher). An adjustable skim time allows for an extended skim period (2-60 seconds) to reduce surface mineral accumulation. The fill valve remains energized for the designated delay time. Access this adjustment through the key pad sub-menu. (See pages 21 and 31.) Probe C provides low water protection for the heating elements. If the water level falls below probe C, the heaters are de-energized. (See figures 17-1 and 17-2.)

In addition to controlling the water level, VAPOR-LOGIC determines when the heaters are turned on. If there is a call for humidification, even during the fill cycle, the heating elements will stay on to provide continuous output.

Figure 17-1: Conductivity Probe System (VLC)

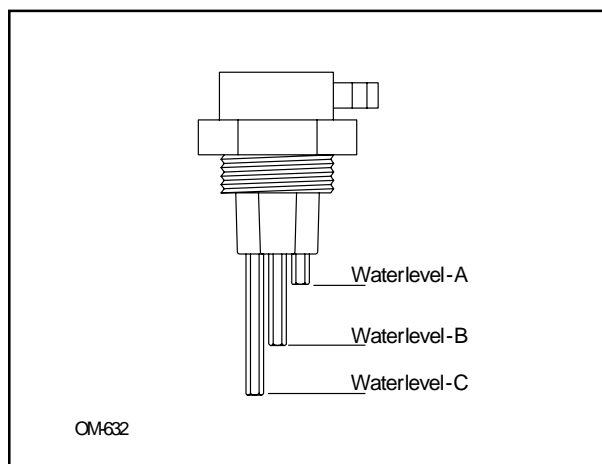

VAPOR-LOGIC® FUNCTION KEYS SELF-TEST PROCEDURE

The key pad/digital display completes the advanced VAPOR-LOGIC system. The key pad with the digital LCD read-out provides descriptions of any faults detected by VAPOR-LOGIC, continuous scrolling of all functions and conditions, and access to VAPOR-LOGIC main and sub-menus in order to change operating parameters.

The standard key pad/digital display is identified as the "Local" module by the VAPOR-LOGIC microprocessor.

Important: When a second key pad is supplied, a jumper must be set so VAPOR-LOGIC will identify it as "Remote."

Digital Display Printed Circuit Board Rev "A" through "D"

(See figure 18-1)

J1, J2 Same as VAPOR-LOGIC control board. (See page 14 in the VAPOR-LOGIC O & M.)

J4 A plastic connector shunt placed over J4 pins will terminate the end of line communication.

J5 A plastic connector shunt or jumper placed over J5 pins will initiate self test of key pad function keys in conjunction with J6.

J6 A plastic connector shunt placed over J6 pins will identify the key pad/digital display as the second, or remote operating device, to the VAPOR-LOGIC microprocessor. Also part of self test of key pad associated with J5.

DRI-STEEM does this on Rev "E" by attaching a connector shunt across location 1 of J3 connector pins on the digital display printed circuit board. (See figure 8-2 for location.)

Figure 18-1: Digital Display Printed Circuit Board Connections (Rev "A" through "D")

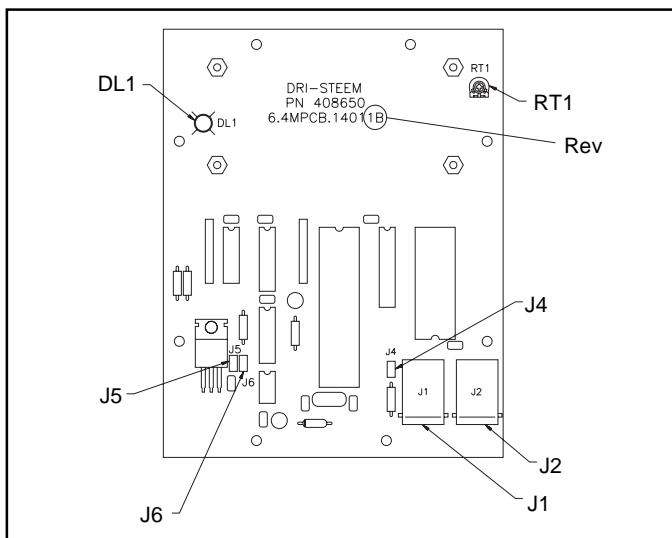

RT1 You may adjust the visual vertical angle at which the display reads using this control. Turning in a clockwise direction will direct the angle of view above center. (Later models have wide angle displays and use fixed resistors to set viewing angle.)

DL1 The indicator light will blink on and off at a constant heartbeat rate to indicate that all system controls are operating properly.

CAUTION: Do not connect or disconnect modular cable on key pad/digital display from VAPOR-LOGIC control board while power is applied. A communication failure will most likely take place.

Digital Display Printed Circuit Board Rev "E"

(See figure 18-2)

J1, J2 Same as VAPOR-LOGIC control board. (See page 14 in the VAPOR-LOGIC O&M.)

J3 Four connector shunt locations
Location 1 - Identifies local or remote key pad.
Location 2, 3, 4 part of self test function of key pad see figure 8-2.

J4 A plastic connector shunt placed over J4 pins will terminate the end of line communication.

DL1 The indicator light will blink on and off at a constant heartbeat rate to indicate that all system controls are operating properly.

Figure 18-2: Digital Display Printed Circuit Board Connections (Rev "E")

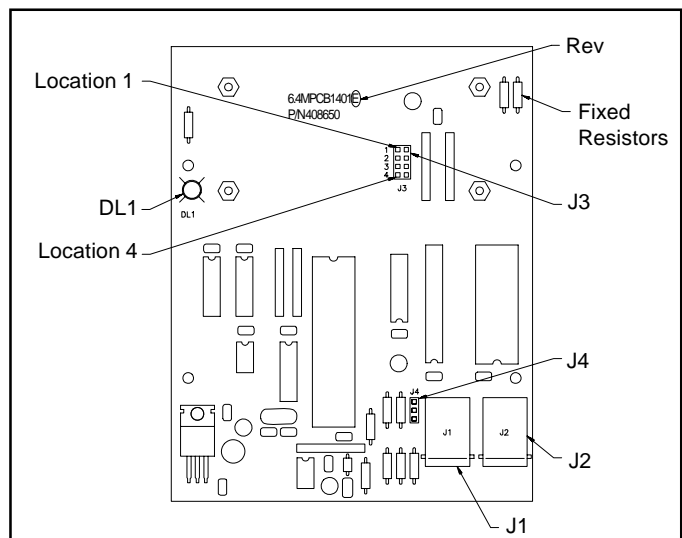

VAPOR-LOGIC® FUNCTION KEYS SELF-TEST PROCEDURE

Key Pad Rev "A" through "D" (See figure 18-1 on page 18, to identify Rev.)

To perform the operation test on the function keys:

1. Turn power off.
2. To access the printed circuit board, remove the front section of the key pad. (Apply pressure to tab at the bottom of the keypad.)
3. Remove the connector shunt from the single pin of J5 and reposition it across the pair of J5 pins.
4. Restore power.
5. The display will read: "DISPLAY DIAG. TEST" on the top line of the display, while alternately flashing "ADJUST CONTRAST" and "SHORT J6 TO CONT" on the bottom line. Display has triview RTI, on key pad P.C. board can be adjusted for optimal contrast or viewing angle (see figure 18-1).
6. Place the second connector shunt across J6 pins. This will initiate the self-test of key pad function keys.
7. The prompt, "PRESS <1>" will appear on the bottom line. Press key number "1." If key number "1" operates satisfactorily, the key pad will bring up the next prompt: "PRESS <2>." This process will continue, from left to right, top row to the bottom row, until all the keys have been tested.
8. Remove connector shunt J5 and reposition to a single pin of J5 and verify Heart Beat Led is blinking.
- 8a. At this point, the test is complete. Set Jumper J6 to its original position. **IMPORTANT:** If the key pad was identified as a "Local" display, remove connector shunt from the pair of J6 pins and reposition to a single pin of J6.
9. Re-connect front section of the key pad to the back section.
10. Press the "RESET" button on the sub-panel inside the control cabinet and hold for a few seconds to restart VAPOR-LOGIC.

Key Pad Rev "E" (See figure 18-2 to identify Rev.)

To perform the operation test on the function keys:

1. Turn power off.
2. To access the printed circuit board, remove the front section of the key pad. (Apply pressure to tab at the bottom of the key pad.)
3. Remove the four connector shunts from the single pins of J3 and reposition the shunts across each pair of pins in location 1 through 4.
4. Restore power.
5. Key pad display will present "DISPLAY DIAG. TST. TOGGLE JUMPERS." This text is the initial start for the self test of the key pad.
6. Disconnect shunt connector from J3, location 1, and re-connect. If connector made positive electrical connection VAPOR-LOGIC display will state "J1 OKAY."
7. Repeat test as stated in item 6 for locations 2-4.
8. If all shunt connectors pass their test VAPOR-LOGIC will prompt you to self test the key pad.
9. The first display, "PRESS <1>" will appear. Press key number "1." If key number "1" operates satisfactorily, the key pad will bring up the next prompt: "PRESS <2>." This process will continue, from left to right, top row to the bottom row, until all the keys have been tested.
10. VAPOR-LOGIC will self test SRAM, if operation is proper the display will state "SRAM OKAY," Press "ENT" key. The last test will signal if all functions are operating properly by blinking off-on the LED lamp on the board. The display will read "CHECK LED," press "CLR" key.
11. At the completion of the test, remove all four connector shunts J3 and reposition to a single pin of J3, **IMPORTANT:** If the key pad was identified as a "Remote" display, leave connector shunt across the pair of J3 pins at location 1.
12. Test complete.
13. Re-connect front section of the key pad to the back section.
14. Press the "RESET" button on the sub-panel inside the control cabinet and hold for a few seconds then release to restart VAPOR-LOGIC.

VAPOR-LOGIC® KEY PAD / DIGITAL DISPLAY OPERATION

Key Pad Key Descriptions

(See figure 20-1.)

MODE

The “mode” function transfers VAPOR-LOGIC from the automatic scrolling mode into the Main Menu format. You may then scroll through the main menu using the arrow keys to find the item of interest. After selecting the item, press the “ENT” key. VAPOR-LOGIC will take you into the sub-menu and display the present data held in memory for that item. To change the data in memory, enter the new information using the 0-9 keys. After new information is keyed in, press the “ENT” key to have VAPOR-LOGIC read the new information and store it in the microprocessor memory. Press “mode” to return to the automatic scrolling mode.

ARROWS

The “up” and “down” arrows will allow you to scroll through the VAPOR-LOGIC main menu one step at a time.

ENT

The “enter” function will display the information held in VAPOR-LOGIC sub-menu memory and will also enter new data into the sub-menu memory.

CLR

The “clear” function will clear any new data presented to VAPOR-LOGIC sub-menu. Pressing this key will also return you to the VAPOR-LOGIC main menu from the sub-menu. Pressing <“CLR”> a second time will place you into “AUTO” mode.

0-9

The number keys allow you to enter new data into a VAPOR-LOGIC sub-menu.

TEST or *

On systems running VAPOR-LOGIC firmware V1.01 through V1.10., pressing this button will initiate self-test cycle on the humidifier which can be monitored for correct operation. The test mode will perform an on-off cycle of fill and drain valves and all electrical contactors.

Figure 20-1: Key Pad

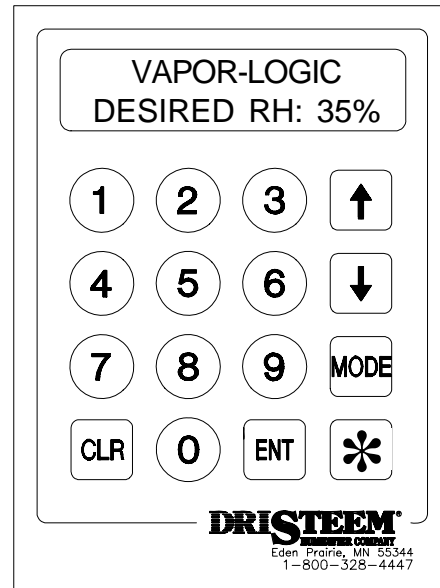

OM-335-3

(When multiple humidifiers are incorporated, each humidifier’s fill and drain valves and contactors are cycled on-off, one humidifier at a time.) No other functions are accessible during a “test” cycle. If the humidifier is in operation at the time the “test” function is initiated, all humidifier electrical devices are turned off before the cycle begins.

On the key pad/digital displays with firmware V2.01 and higher. The “*” function will transfer one of the automatic scrolling items on the lower line to the upper line for review. The item selected will be updated every few seconds if a change is detected by VAPOR-LOGIC and will remain isolated on the upper line while the remaining functions continue scrolling on the lower line. Typical items that may be selected from Auto Scroll for review are: Actual RH, Actual High Limit RH, Glass Temperature, System Demand, and System Output.

VAPOR-LOGIC® KEY PAD / DIGITAL DISPLAY OPERATION

Accessing VAPOR-LOGIC Sub-Menu Information

To access any sub-menu from the main menu, press <"MODE"> and then use the up and down arrow keys to scroll through the available menu options until the menu item you want is shown. Press <"ENT."> As an example, this is how you would access the first sub-menu item and change the parameters:

1. Press <"MODE.">
 1. Set % RH will be displayed.
2. To view present set point, press <"ENT"> and VAPOR-LOGIC will bring up the current information:
 1. Set % RH
_: 35% RH
3. You may now either return to the Main Menu (press <"CLR">) or enter a different set point. To enter a new set point, press the numerical keys that correspond. For instance, if you want to enter a set point of 50%, press <"5"> followed by <"0."> The display will read:
 1. Set % RH
50: 35% RH
4. Press <"ENT"> to instruct VAPOR-LOGIC to replace the old set point with the new information you just entered. The key pad should now display :
 1. Set % RH
_: 50% RH

Note: If you exceed the range limits of any sub-menu (see chart on pages 29 and 30), VAPOR-LOGIC will prompt: "Out of Range." Press <"CLR">. This will allow you to enter a new value within range.

5. Scrolling up and down (using the arrow keys) will allow you to choose another sub-menu. Press <"CLR"> again to return VAPOR-LOGIC to <"AUTO"> mode. (Press <"MODE"> at any time while in the Main Menu or Sub-Menu items to return to "AUTO" mode.)

Sensor Trim Calibration

VAPOR-LOGIC can compensate for differences in sensing device accuracies caused by sensor placement, environment, aging, etc. By accessing the VAPOR-LOGIC sub-menu (press <"MODE"> key) and scrolling to the appropriate sensor trim menu (using arrow keys), pressing the <"ENT"> key will allow you to input a two-digit trim factor to the sensor input. (Note: As long as the adjusted value does not exceed the range limits for each sensor, the trim value will allow you to compensate for small variances in the readings.)

Example: The desired room RH is 50%, the display shows 48% RH, and the actual value measured by some other means is 51%.

1. Access the trim % RH sub-menu as directed above.
2. Key in the RH value: 51
3. Press "ENT." VAPOR-LOGIC will then enter the value into memory.
4. Press "CLR" twice to complete the adjustment.

Note: To clear any trim value, enter "00" into the sub-menu. This will return you to the actual value being sensed.

VAPOR-LOGIC® KEY PAD / DIGITAL DISPLAY OPERATION

Sub-Menu Instruction for Changing Control Input Signal on Version Advanced V2.04 Firmware Only

1. Power On, VAPOR-LOGIC in Auto Scroll Mode, press <"MODE"> key.
2. Press the <"DOWN"> key. VAPOR-LOGIC will display:
 1. Change RH IN.
3. Press the <"ENT"> key.
4. VAPOR-LOGIC will display the present input that the system is programmed for.
Four choices:
 - 1) "4-20ma XMTR", Room or Duct humidity transmitter by DRI-STEEM.
 - 2) "4-20ma STAT", 4-20ma signal by others.
 - 3) "1-15 VDC STAT", 1-15 VDC range signal by others.
 - 4) "0-135 OHM STAT", 0-135 OHM range signal by others.
5. Press the <"UP"> arrow until you index to the input you desire.
6. Press the <"ENTER"> key; VAPOR-LOGIC asks if you **"are sure you want to change"**. If you do not want to change, press <"CLEAR"> key, then press <"MODE"> key returning you to Auto Scroll. If you want to change, press <"ENTER"> key.
7. VAPOR-LOGIC will display three functions and continues to repeat the functions until they are completed:

First - Will request you to move J9 Shunt Connector to "I", "V", or "R" pins.

Second - Will request you to wire to J8 Terminal Block terminals +6, -7 for signal by others or +5, -6 for transmitter connections.

Third - Push and hold Reset for 5 seconds, then release.
8. Change is completed.

VAPOR-LOGIC® KEY PAD / DIGITAL DISPLAY OPERATION

Instruction to Activate Digital Meter for Version Advanced V2.04 Firmware Only

1. Power on, VAPOR-LOGIC in Auto Scroll Mode
2. Push <"RESET"> push-button. Hold for 3 seconds, release.
3. When the word "INITIALIZING" appears across the keypad display, enter code 11201929. If done correctly, the word DRISTEEM will be spelled out one letter at a time.
4. Press the <"ENT"> key.
5. VAPOR-LOGIC will prompt you for an address - enter "ADDR._____". Press the <"STAR"> or <"ASTERISK"> key.
6. VAPOR-LOGIC will display a double star or asterisk "***".
7. Press the <"ENT"> key.
8. You have now entered into the VAPOR-LOGIC digital reading meter. Depending on your program features, some of the meter readings listed below

will be displayed. Use the "UP" arrow to index through the available items.

RH Sensor - ?? %RH and ? milliamperere Reading
HL Sensor - ?? %RH and ? milliamperere Reading
Temp. Sensor - ?? °F. and ? milliamperere Reading
Off-On High Limit - open or closed State
Air Flow Switch - open or closed State
Aquastat - open or closed State
Single Stage In- open or closed State
Multi Stage 1- open or closed State
Multi Stage 2- open or closed State
Multi Stage 3- open or closed State
Multi Stage 4- open or closed State
Water level - Volts A.C. reading on all three water probes, left to right read Top, Center, Bottom.

Probe Signal 2.5 VAC, **without** water in contact with probe rods.

Probe Signal 0.0 VAC **with** water in contact with probe rods.

Water Level (DI) - open or closed state.

Power Supply - ?? VDC, normal 20-21 VDC

Signal by other readings

RH Stat - ? milliamperere reading, 4-20 ma normal range
RH Stat - ? volts D.C. reading, 0-15 VDC normal range
RH Stat - ? OHMs resistance reading, 0-135 OHMs normal range

9. After review of the metered values, press the <"MODE"> key to return keypad to "AUTO" Scroll Mode.

VAPOR-LOGIC® CONTROL SCHEMES

Off-On Control

The first and simplest control scheme, this operation does what its name implies: the output device turns fully on then fully off. The off-on humidistat differential is designed into the control action between off-on switching points. The differential is established at a range sufficient to prevent output short-cycling. See figure 24-1. VAPOR-LOGIC offers single output control or multiple output control on larger humidifiers by using integral PE switches or external stage or step control switches by others. Off-on control may also be used in multiple-zone humidifying applications by controlling the opening and closing of area zone valves.

Time Proportioning Modulation

For more precise control, the time proportioning system operates in the same way as off-on control when the controlled relative humidity is far enough away from set point. But when controlled relative humidity approaches set point, the system enters a control range which provides proportional control called the throttling range, which is positioned symmetrically around set point. In

this range, the output device is switched on and off inversely proportional to the actual RH relative to the setpoint at an established cycle rate. This cycle rate is adjustable from 15 to 99 seconds; for TP modulation the VAPOR-LOGIC default is 20 seconds.

Because of the limitations of mechanical contactor cycling rate design, to increase the effective control potential of time proportioning, a solid state SCR power control is also offered. The SCR cycle rate is reduced to one second; this provides a shorter interval of output modulation.

The TP modulating control operates as follows, at the lower limit or below set point, within throttling range, the *on time* is greater than the *off time*. As the process relative humidity approaches set point and just above, the amount of *on time* decreases as the *off time* increases. This action, in effect, is time proportioning modulation. The power delivered to the humidifier over time is reduced. This on and off cyclical action continues until a stable relationship is achieved around set point. See figure 25-1.

Figure 24-1: On-Off Differential

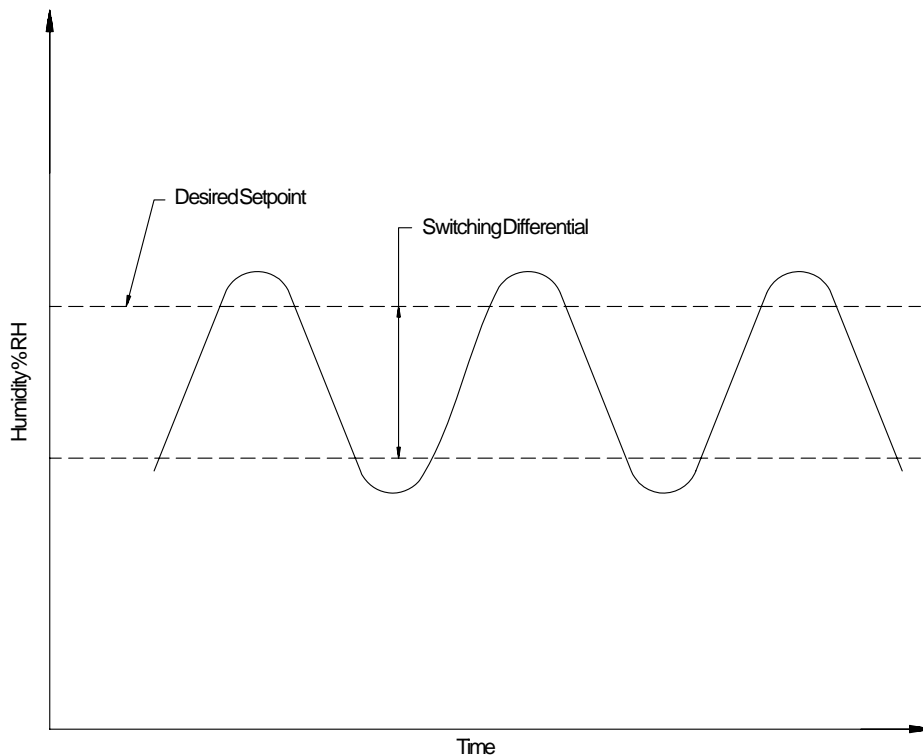

OM587

VAPOR-LOGIC® CONTROL SCHEMES

For a large humidification load, when the application dictates a single humidifier with multiple outputs and/or multiple humidifiers electrically tied together in a very large common system, the time proportioning action is still the same as the humidifying single output, except that the additional electrical humidifying outputs are sequenced on or off as demand signal dictates. The additional outputs are turned on (100%) and off (0%) at a rate equal to the delay time. The delay time has a range of 4 to 99 seconds. The VAPOR-LOGIC default is 20 seconds. See figure 25-1.

Example of Operation

Cycle Rate: 30 seconds
 Delay Rate: 20 seconds
 Control Span: 6-9 VDC
 Input Signal: 1-15 VDC controller or humidistat

Time proportioning of the humidifier load takes place only when the humidistat output signal is within 6 to 9 VDC range. As the signal drops below 6 VDC, the time proportioning heater turns off and stages any additional

heaters off, one heater for every 20 second delay period the signal remains below 6 VDC. As the humidifier signal increases to 9 VDC, the time proportioning heater will increase to 100% output; on multiple heater applications at the point where the demand exceeds 9 VDC, the time proportioned heater will reset to zero output and turn on the first staged output to 100%. For every 20 second delay period that the signal is above 9 VDC, an additional staged output will be energized, with the time proportioned output re-energized as the last stage when a full output demand is requested. As the humidistat signal stabilizes within the throttling range (6-9 VDC), the modulated output will continue to humidify on single output humidifiers and will also continue to modulate with any combination of additional staged outputs on multiple heater systems.

Standard Control Input Signals

- 4-20 mA (throttling range or control span 5-19 mA)
- 1-15 VDC (throttling range or control span 6-9 VDC)
- 0-135 ohms (throttling range or control span 17-117 ohms)

Figure 25-1: Time Proportioned On-Off (control signal by others)

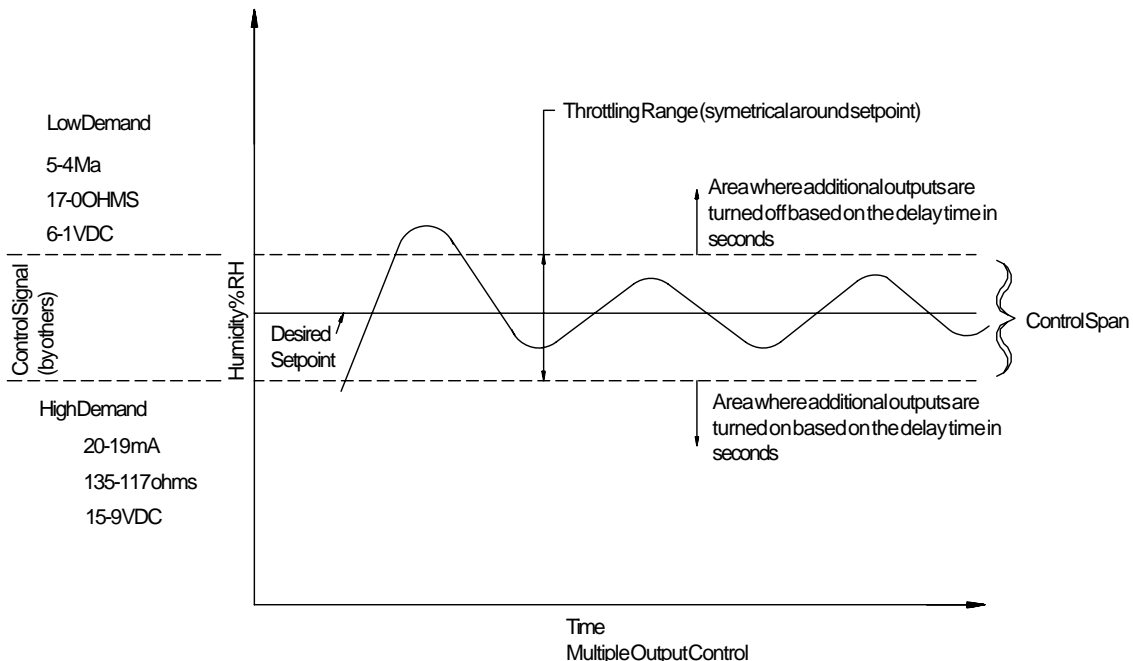

OM-589

VAPOR-LOGIC® CONTROL SCHEMES

VAPOR-LOGIC also has the capability of being the primary humidity controller when a humidity duct or room transmitter is furnished. The digital key pad display module allows you to monitor actual set point and to change desired set point when necessary.

The time proportioning function operates when actual % RH is within the throttling range. When the actual % RH falls below set point and out of throttling range 100% output demand is necessary. If the actual % RH increases above and out of throttling range, humidifier turns off completely. See figure 26-1.

DRI-STEEM Offers Five Forms of Time Proportioning:

- TP Modulation for single electrical output humidifiers
- TP/Sequencer Modulation for multiple electrical output humidifiers
- SCR/Sequencer Modulation using solid state power controller with sequence of multiple electrical humidifier outputs
- 100% SCR Modulation is total modulation of all the electrical outputs together through a SCR power control system without sequencing
- Varying 6-9 VDC or 1-10 VDC analog signals to modulate steam or hot water valves

Figure 26-1: VAPOR-LOGIC Time Proportioned Controller

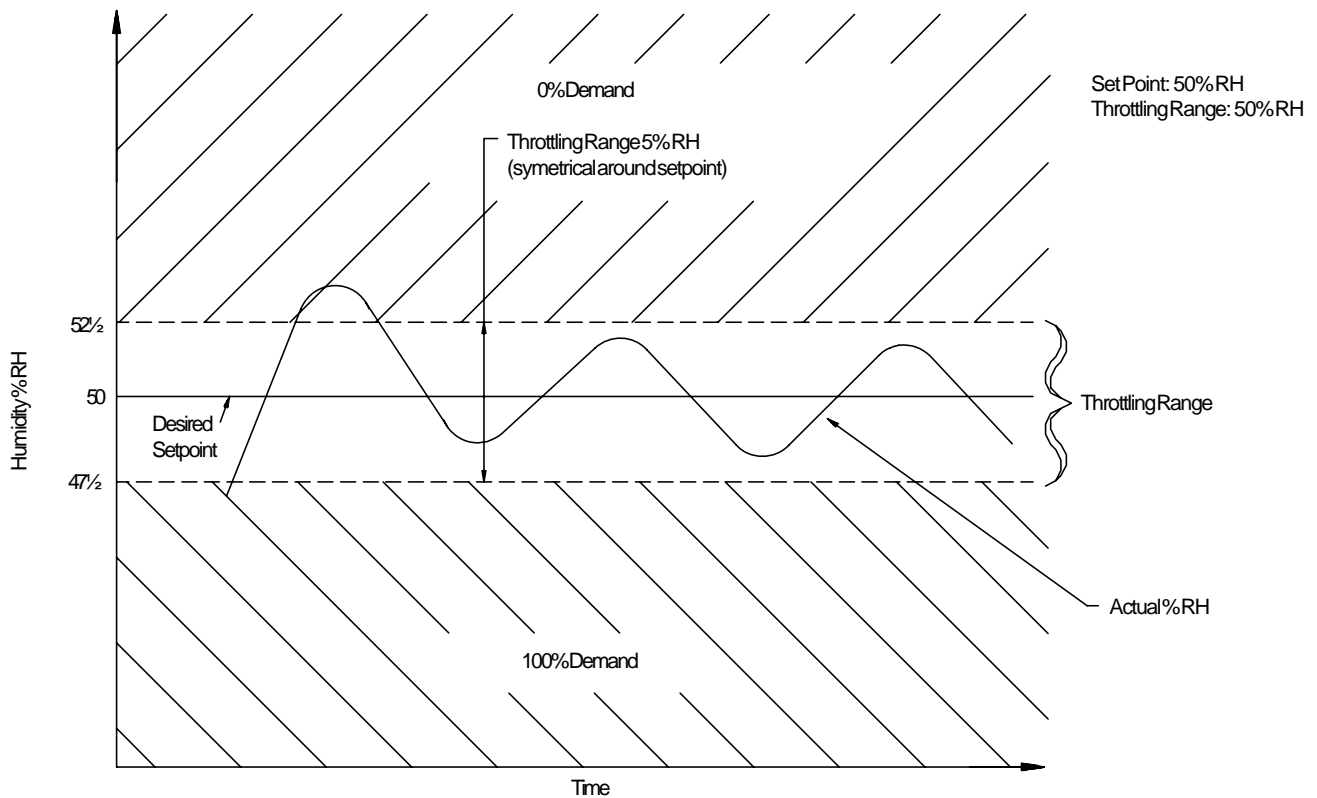

OM-590

VAPOR-LOGIC® PID CONTROL LOOP: TERMINOLOGY

Optional Feature

Using the PID control loop in conjunction with VAPOR-LOGIC gives you the potential for unprecedented control accuracies. You are able to fine-tune the control system to meet your specific humidification needs. Understanding the terminology of PID, and the purpose for each inclusion, will greatly assist you in using VAPOR-LOGIC PID to its full potential.

Proportional Band (P)

Adjustable range: 100, or 20% RH, to 1000, or 2% RH.

The proportional band is the % RH band below the set point where the control will time-proportion the output via a contactor or solid state SCR preset at 10% RH. Or, it is the % RH band below the set point where the control will provide a steady state analog VDC signal to a steam or hot water valve.

If the proportional band is too narrow, on-off control action hunting will be evident. There will be minimal

proportional action.

If the proportional band is too wide, proportional action will be present, but there will be slow response to change. The greatest potential in this situation would be for control to drift away from the desired set point. (See figure 27-1.)

Integral Term (I)

Adjustable range: 50 to 500 factor, with default of 250. Higher factor number greater the integral effect.

The integral, or reset, term will reduce the actual set point droop from the desired set point when added to the proportional band control.

To do this, the integral term algorithm actually shifts the proportional band around the desired set point to increase or decrease the output as needed.

If the integral term is too little, droop will be evident.

If the integral term is too large, on-off cycling, or hunting, will be evident. (See figure 27-2.)

Figure 27-1: Proportional Band

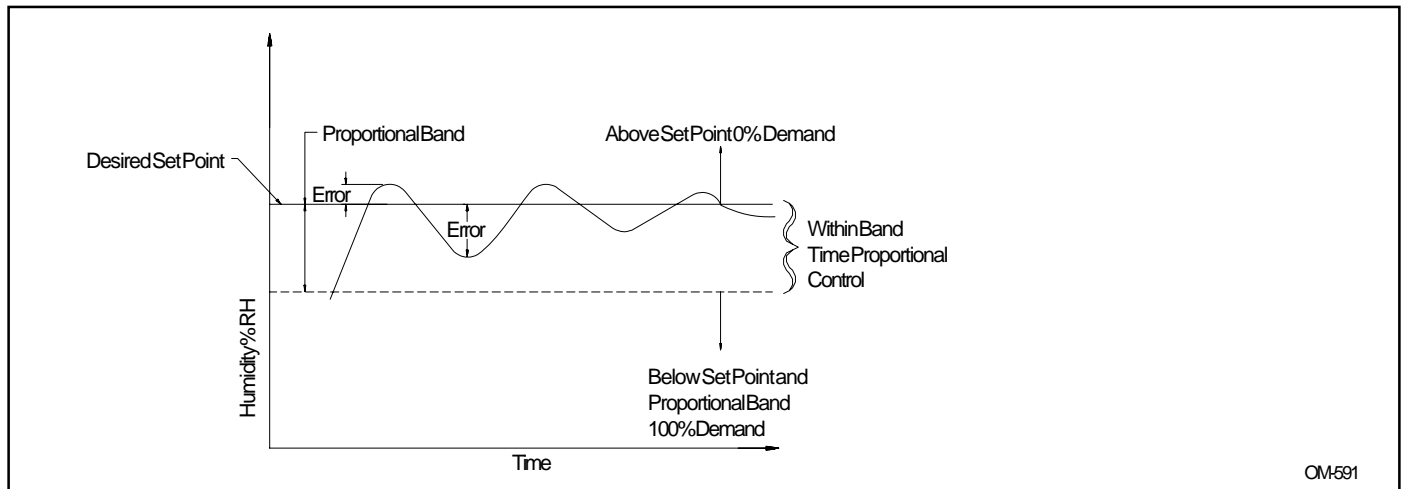
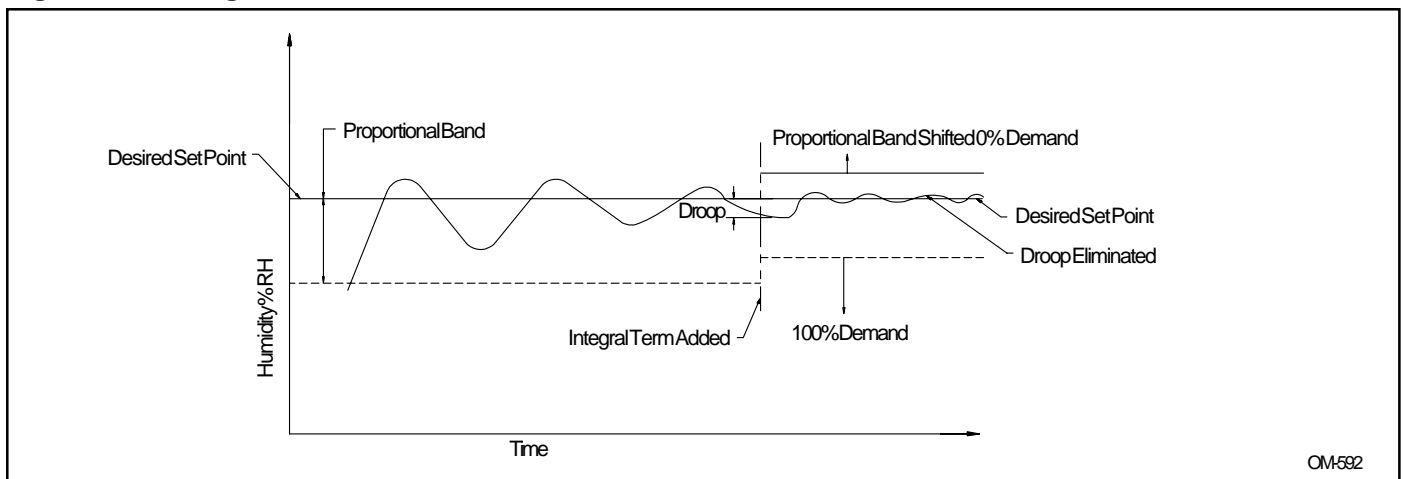

Figure 27-2: Integral Term



VAPOR-LOGIC® PID CONTROL LOOP: TERMINOLOGY

Derivative Term (D)

Adjustable gain factor range: 0 to 500, with default of zero. Increase in numerical value increase gain.

The derivative, or rate (anticipatory), term reduces the potential for overshoot and undershoot around the desired set point when added to the proportional band and Integral control functions. The derivative algorithm measures the rate of % RH change that is taking place over time and forces the control into the proportioning actions on an accelerated basis to slow the change.

As the rate of change diminishes, the derivative term becomes less effective on the proportional band. (See figures 28-1 and 28-2.)

Important: In 80% of the humidification applications, the derivative term is not necessary, which explains why the default value is zero.

If there is too little derivative term, overshoot is evident.

If there is too much derivative term, there will be very poor control, frequent system disturbances, or increased time to reach the desired set point.

Sample Interval

Adjustment range: 5 to 1200 seconds; the default value is 30 seconds.

The sample interval is the time interval (in seconds) during which VAPOR-LOGIC reviews all the controlling parameters (desired and actual RH set points, PID terms, and output percentage) and then makes the necessary adjustments to the control output to achieve the desired set point.

If the sample interval is too short, over control and system on-off hunting will be evident.

If the sample interval is too long, there will be poor response to changes and large errors from the desired set point.

Figure 28-1: Proportional Action Without Derivative Gain

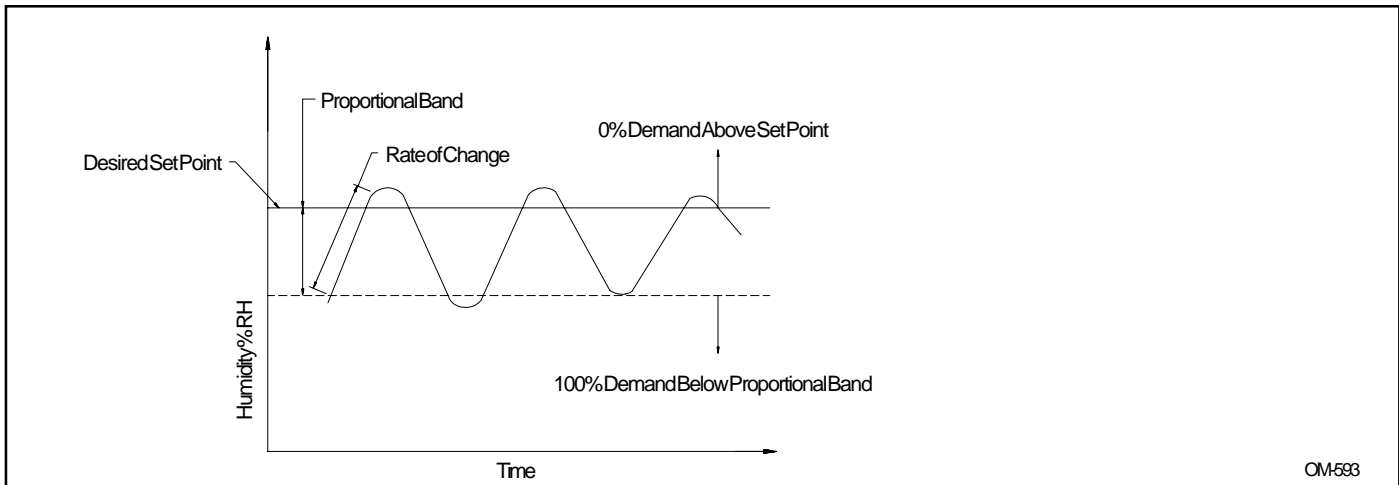
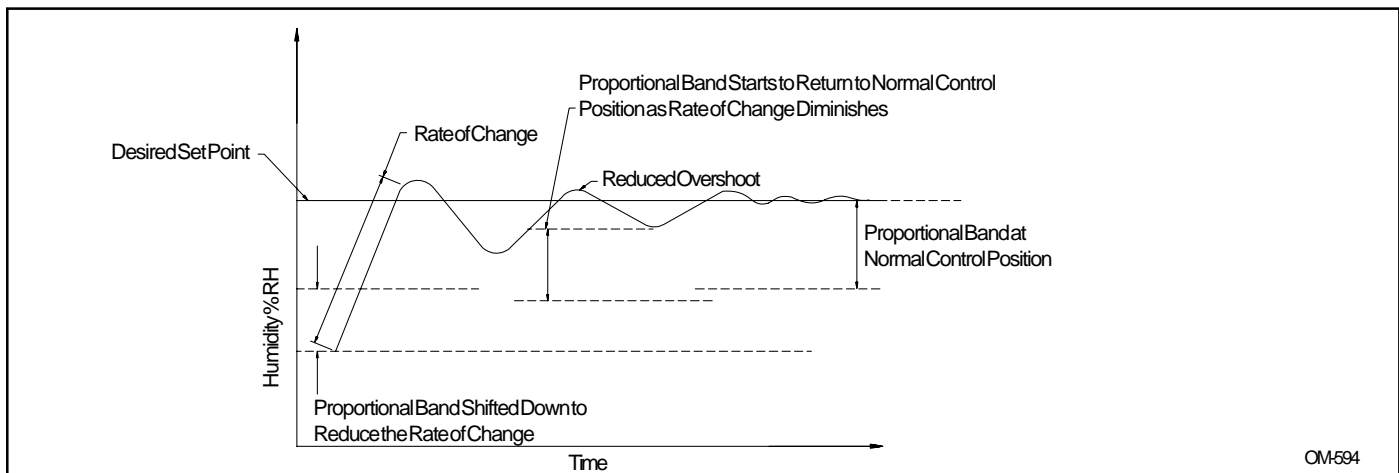

Figure 28-2: Proportional Action With Derivative Gain



VAPOR-LOGIC® PID CONTROL LOOP: TUNING

In this section, we will focus on the VAPOR-LOGIC P.I.D. controller as the primary control in a closed loop system that needs to be tuned for optimum performance. The availability of these adjustments provide a means to work with different humidification applications.

The following steps are general and applicable to most humidification situations. Each setting is described in sequence: proportional band, integral, derivative, and sample interval rate.

Precautions

- Take your time when tuning the VAPOR-LOGIC system.
- Evaluate the system dynamics: slow changes in large humidification areas or humidification for comfort, medium changes for most applications, and fast changes for system RH's that can change in seconds, controlling within a duct or controlling downstream from the humidifier.
- Do not change more than one control adjustment at a time, allowing the system to settle down and reach a state of equilibrium before making another change.
- Remember that the time you spend tuning the VAPOR-LOGIC system is in direct proportion to the accuracy of control you need.

Potential Accuracies

- TP modulation (contactor): $\pm 2-5\%$ RH
- TP modulation (SCR): $\pm 2-4\%$ RH
- 100% SCR modulation: $\pm 1-3\%$ RH
- 100% SCR modulation (DI/RO water systems): $\pm 1-2\%$ RH
- Modulated steam and hot water valves: $\pm 1-4\%$ RH

The P.I.D. controls are listed in the sequence in which they should be adjusted.

Proportional Band Adjustment

The proportional band adjustment is the means of selecting the response speed (gain) or sensitivity of the VAPOR-LOGIC controller to achieve stability in the system. The proportional band is measured in the percent RH span that must be wider than the natural dynamics of the system and yet not wide enough to dampen the system response. (Time Proportioning Output.)

The internal cycle time is pre-set to switch faster than the natural dynamics of the system.

The tuning procedure is very simple if a humidity recorder is available to monitor the actual % RH variable. If a recorder is not available, observe the process response and record readings over a defined time period using a wet/dry bulb psychrometric sling.

If there are oscillations with the proportional band at its narrowest setting (not zero), the adjustment of the proportional band should be increased in small increments until the offset (droop) starts to increase. When the proportional band has been tuned properly, you will see system stability, but an offset (droop) from the set point should be evident. At this point in tuning the system, the % RH variable should be in a state of equilibrium, but not right at the desired set point. (Refer to figures 29-1, 29-2 and 29-3.)

Figure 29-1:

If the system response looks like this, decrease the proportional band by a factor of two.

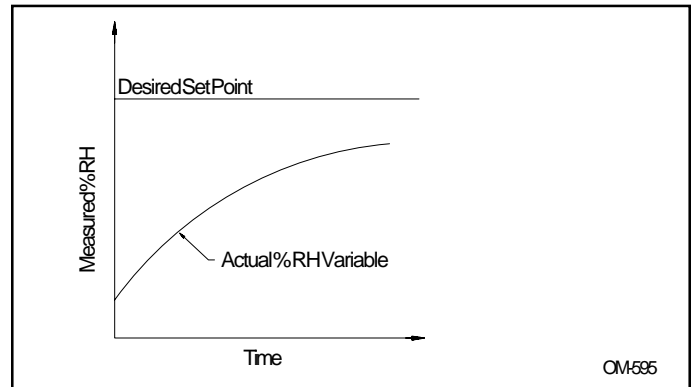

Figure 29-2:

If the system response looks like this, increase the proportional band by a factor of two.

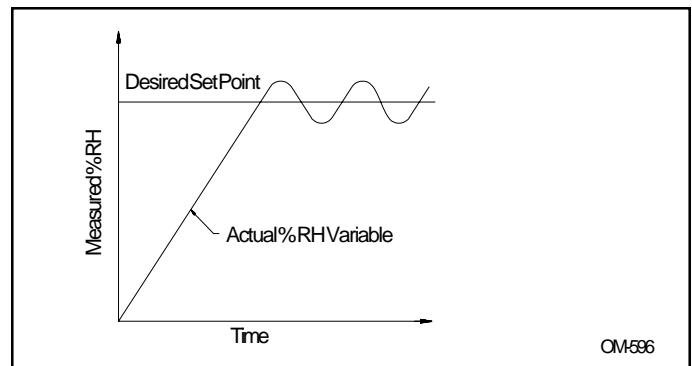
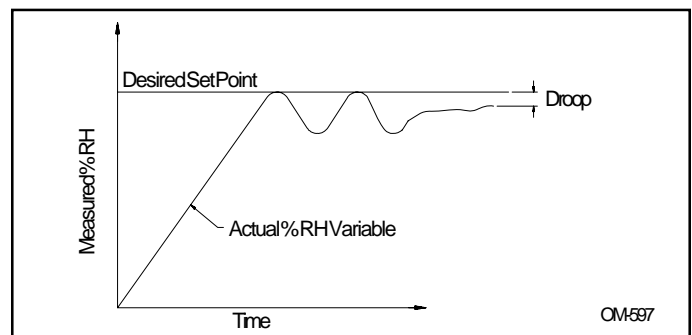

Figure 29-3:

If the system response looks like this, the proportional band is very close to the correct setting for this system. Increase the proportional band in small increments until the % RH stabilizes.



VAPOR-LOGIC® PID CONTROL LOOP: TUNING

Integral Adjustment

The VAPOR-LOGIC integral adjustment is tuned at this point in time to adjust for the droop that is caused by the proportional output. (VAPOR-LOGIC default is 250 derivative adjustment for integral term.) The operator will make small integral adjustments in the proper direction (increase or decrease) to bring about the alignment of the actual % RH and the desired % RH set point.

Please make small changes in the integral adjustment (range 0 to 1000) and allow the system to return to a state of equilibrium before making additional changes. This may take several system cycle times. Also, the integral will have to be changed if the % RH set point or other dynamic characteristics are changed substantially.

Derivative Adjustment

The derivative adjustment is the last control parameter adjustment to be made. In 80% of the humidity control applications, the default value of zero is sufficient. The derivative adjustment functions to reduce or eliminate overshoot (excursions above or below desired % RH set point). It has an adjustment factor (range 0 to 500) which must be tuned to work with the overall system dynamics.

The initial setting for the derivative adjustment should be at the smallest integer possible (least corrective action). Increase the integer in small increments and increase the % RH set point moderately after each adjustment. Observe the actual process of the approach of the % RH to the set point. If it overshoots, continue to increase the rate integer in small increments. Then increase the set point % RH moderately until the optimum approach to the desired set point is achieved. If at some point the system becomes very sluggish, or doesn't reach the new set point at all, excessive derivative action has been adjusted in the control system. The amount of derivative value must be decreased to reduce the "dampening" effect.

Sample Interval Adjustment

The sample interval default setting is at 30 seconds, and this will perform satisfactorily in most applications. The range of interval time is from 4 to 1200 seconds. Too short an interval will cause over control, while too long an interval will cause sluggish control.

Important: Any dramatic set point changes or system dynamic variations will require a re-tuning of the control parameters (P.I.D.).

MAIN MENU/AUTO SCROLL INFORMATION

The following pages contain information about the digital read-outs that VAPOR-LOGIC® communicates. Not all the scrolled information appears in every system. This is dependent on the system configuration. A variety of preset system conditions and programmable parameters that ultimately control the humidification system, as well as a trouble-shooting guide to help you with operational procedures. The charts are organized based upon when or why the information is communicated.

MAIN MENU READ-OUT	MAIN MENU DESCRIPTION	RANGE	DEFAULT	AUTO SCROLL	AUTO SCROLL READ-OUT
"SET % RH SP"	Room Set Point (1)	20-80% RH	35%	yes	"DESIRED RH: %" "ACTUAL RH: %"
"TRIM % RH"	Trim Range (1)	±10% from present set point reading	No trim.	no	
"SET RH TR"	Throttling Range (1)	2-20% RH	11% RH	no	
"SET HL RH SP"	Duct Set Point (VAV Option) (2)	50-90% RH	70% RH	yes	"MAX. HL RH: %" "ACT. HL RH: %"
"TRIM HL %RH"	Trim High Limit Range (2)	±10% from present high limit set point reading	No trim.	no	
"TRIM TEMP"	Trim Temperature Range (3)	±11°C from present glass temperature reading	No trim.	no	
"SET ADS INTERVAL"	Auto Drain Sequence Interval (4)	1-99 hours	50 hours	no	
"SET ADS DUR"	Auto Drain Sequence Duration (4)	1-30 minutes	8 minutes	no	
"SET AFS DUR"	Auto Flush Sequence Duration (4)	1-30 minutes	8 minutes	no	
"SET SKIM DUR"	Skim Time Duration	2-60 seconds	2 seconds	no	
"TIME TO ADS"	Time Until Auto Drain Sequence (in hours, minutes, seconds) (4)	1-99 hours	50 hours	no	
"TIME TO SRVE"	Time Until Recommended Service (in hours, minutes, seconds) (4)	Counts down from 2000 hours.	2000 hours	no	

MAIN MENU/AUTO SCROLL INFORMATION

MAIN MENU READ-OUT	MAIN MENU DESCRIPTION	RANGE	DEFAULT	AUTO SCROLL	AUTO SCROLL READ-OUT
"SET CYC TIME" (TP Type Control)	Cycle Time (1)	15-99 seconds	60 seconds	no	
"SET CYC TIME" (SCR Type Control)	Cycle Time (1)	4-99 seconds	4 seconds	no	
"SET DLY TIME"	Multiple Heater Delay Time (1)	4-99 seconds	20 seconds	no	
"SET KP"	Proportional Band (5)	100-1000	10% (200)	no	none
"SET KI"	Integral Gain Factor (5)	50-500	5% (250)	no	none
"SET KD"	Derivative Gain Factor (5)	0-500	0 (000)	no	none
"SET SMPL INT"	Sample Interval (5)	5-1200 seconds	0030 (30 seconds)	no	none
AUTO SCROLL DESCRIPTION				AUTO SCROLL	AUTO SCROLL READ-OUT
Heater One Demand %				yes	"K1 DEMAND: %"
Heater Two Demand %				yes	"K2 DEMAND: %"
Heater Three Demand %				yes	"K3 DEMAND: %"
Heater Four Demand %				yes	"K4 DEMAND: %"
Total System Demand %				yes	"SYS DEMAND:%"
Steam Ouput (lbs/hr)				yes	"SYS OUT: #/HR"

- (1) Modulation type control
- (2) Modulation type control with VAV option
- (3) Modulation type control with % RH offset option
- (4) VPC Series with Auto-Drain feature
- (5) Modulation type control with PID control option feature

DIGITAL DISPLAY READ-OUTS

READ-OUT DISPLAYED	DESCRIPTION
*"SERVICE"	Humidifier has reached the point where the review of humidifier operations for possible servicing is recommended.
"END OF SEASON"	Humidifier has not had a call for humidity over a 3-day period. All water drains from the tank and VAPOR-LOGIC goes into end of season mode until the next call for humidity.
"DISABLED BY HL"	High limit humidistat has opened.
"DISABLED BY AFPS"	Air flow proving switch has opened.
"STANDBY"	VAPOR-LOGIC is in stand-by mode.
"AUTO DRAIN"	VAPOR-LOGIC is in drain mode.
"AUTO FLUSH"	VAPOR-LOGIC is in flush mode.
"LOW WATER"	VAPOR-LOGIC has detected low water condition in tank.
"FILLING"	VAPOR-LOGIC has instructed fill valve to open to fill tank with water.
"GLASS TEMP °C"	Metric notation of glass temperature.
"SYS OUT KG/H"	Metric notation for kilogram/hour steam output.
"AQUASTAT"	Aquastat control option has activated to heat water for freeze protection.
"VAV OUTPUT LIMIT"	The VAV control package detects high limit condition in duct and begins to limit humidifier output.
"OFFSET RH: __%"	The cold snap offset package detects low glass temperature. The setpoint has been offset to ensure that no frost forms on the glass.
"REPLACE PROBES"	The system has detected the need to replace the probe rod assembly.
"PROBE FAULT"	The system has detected deteriorations of the probe rod assembly to a point that replacement is necessary.

*To clear service message, press "MODE" key to enter into sub-menu, using up-down arrow scroll to "RESET SERVICE" prompt. Press "ENT" key. VAPOR-LOGIC will reset service and establish a new 2000 hour service period. Press "MODE" key to return to "AUTOMODE".

DIGITAL DISPLAY/KEY PAD TROUBLE SHOOTING GUIDE

PROBLEM	POSSIBLE CAUSE	RECOMMENDED ACTION
VAPOR-LOGIC RED INDICATOR LIGHT IS OFF	No control voltage present	Check for proper supply voltage.
	Heater fuses open	Check heater fuses for voltage present at transformer.
	Transformer secondary circuit breaker tripped	Check wiring for shorts; reset breaker.
	Disruption in microprocessor logic	Verify proper control cabinet wiring. Press "RESET" button to reset VAPOR-LOGIC control board.
VAPOR-LOGIC RED INDICATOR LIGHT ON CONTINUOUSLY	VAPOR-LOGIC microprocessor disrupted	Verify proper control cabinet wiring. Press "RESET" button to reset VAPOR-LOGIC control board.
VAPOR-LOGIC RED INDICATOR LIGHT BLINKING ON-OFF (heartbeat)	Normal operation	
VAPOR-LOGIC GREEN INDICATOR LIGHT OFF	Low water in evaporating tank	Check water supply valve is open. System in end of season drain. Low conductivity water (probe system). DI float switch defective or incorrect wiring.
VAPOR-LOGIC GREEN INDICATOR LIGHT ON	Normal operation	Sufficient water in tank.
	Caution	If light is "on" without water in tank, turn off, check wiring, and consult DRI-STEEM.
INDICATOR LIGHT BLINKING ON-OFF (long/short pulses)	Indicates fault condition	See Fault Chart beginning on page 36 for more information. Identify the fault, turn power off, repair, restart.
NO REMOTE FAULT INDICATION	Field wiring not installed	Provide field wiring to a remote fault indicator from VAPOR-LOGIC terminal block J7.
	Field supplied remote fault indicator lamp burned out	Check if lamp is burned out and replace.
	Remote fault VAPOR-LOGIC relay not switching	Check relay continuity (VAPOR-LOGIC terminal J7) for contact closure.
NO READABLE INFORMATION DISPLAYED ON KEYPAD (Continued on next page.)	No power to VAPOR-LOGIC board	Check main supply power. Check control transformer secondary manual reset circuit breaker.
	Modular communication cable disconnected	Connect modular cable.

DIGITAL DISPLAY/KEY PAD TROUBLE SHOOTING GUIDE

PROBLEM	POSSIBLE CAUSE	RECOMMENDED ACTION
NO READABLE INFORMATION DISPLAYED ON KEY PAD (con't.)	Reverse polarity between modular cable and plugs	See page 11 for correct polarity of the modular cable connection to cable plugs.
	Digital key pad lock-up	Press "RESET" button on panel.
READ-OUT NOT AUTO SCROLLING	Digital display in main or sub-menu format	Press "MODE" key.
CANNOT ENTER NEW PARAMETERS INTO MICRO-PROCESSOR THROUGH KEY PAD	Digital display in "AUTO" or main menu format	Press "MODE" key to enter main menu. Press "ENT" key to access data in the main menu item selected.
	New parameters out of range	Press "CLR" key to start over, and enter new parameters within range.

FAULT INDICATOR CODES

FAULT	MASTER (CODE)	SLAVE 1 (CODE)	SLAVE 2 (CODE)	SLAVE 3 (CODE)	DIGITAL DISPLAY READ-OUT
COMMUNICA-TION FAILURE	SSSSS	LSSSS	SLSSS	LLSSS	"1) LOCAL COMM" (Master to local key pad communication failure) "21) REMOTE COMM" (Master to remote key pad communication failure) "2) SLAVE 1 COMM" (System B control board to Master control board failure) "3) SLAVE 2 COMM" (System C control board to Master control board failure) "4) SLAVE 3 COMM" (System D control board to Master control board failure)
LEVEL CONTROL (PROBE FAILURE)	SSLSS	LSLSS	SLLSS	LLLSS	"5) MASTER WATER" (Main humidifier probe and low water failure) "6) SLAVE 1 WATER" (System B humidifier probe and low water failure) "7) SLAVE 2 WATER" (System C humidifier probe and low water failure) "8) SLAVE 3 WATER" (System D humidifier probe and low water failure)
DRAIN VALVE FAILURE	SSSLS	LSSLS	SLSLS	LLSLS	"9) MASTER DRAIN" (Main humidifier water drain failure) "10) SLAVE 1 DRAIN" (System B humidifier water drain failure) "11) SLAVE 2 DRAIN" (System C humidifier water drain failure) "12) SLAVE 3 DRAIN" (System D humidifier water drain failure)
FILL VALVE FAILURE	SSLLS	LSLLS	SLLLS	LLLLS	"13) MASTER FILL" (Main humidifier water fill failure) "14) SLAVE 1 FILL" (System B humidifier water fill failure) "15) SLAVE 2 FILL" (System C humidifier water fill failure) "16) SLAVE 3 FILL" (System D humidifier water fill failure)

FAULT INDICATOR CODES

POSSIBLE CAUSE	RECOMMENDED ACTION
Modular cable to local and/or remote key pads or VAPOR-LOGIC boards not connected	Connect modular cables.
Reversed polarity of modular cable connection to cable plugs	See page 11 for correct polarity of the modular cable connection to cable plugs.
Remote key pad missing J6 cable jumper	Add jumper. (See page 15.)
Modular plug and/or cable connected or removed with power on	Reconnect with power "off" and reset VAPOR-LOGIC.
Improper water level changes inside tank	<p>Verify proper wiring of probe system.</p> <p>Clean probe rod assembly.</p> <p>Probe wiring routed with high voltage wiring.</p> <p>Wiring between control cabinet and humidifier exceeds the recommended 30-foot limit.</p> <p>Check plumbing problems.</p>
<p>When in auto drain sequence, end-of-season, or manual drain, VAPOR-LOGIC allows 20 minutes for the water level to drop from the top probe to below the lowest probe.</p> <p>If the tank does not drain to this level in the time allotted, a fault will be indicated.</p>	<p>Check drain valve wiring.</p> <p>Check for voltage present at the valve. If present, clean or replace valve.</p> <p>Check if the tank drain outlet is plugged. Clean outlet if needed.</p> <p>Reset VAPOR-LOGIC.</p>
<p>When in the fill sequence, VAPOR-LOGIC allows 40 minutes for the water to reach the maximum proper level.</p> <p>If the water does not reach the designated level, and the probe system is not satisfied, a fault will be indicated.</p>	<p>Check water supply shut-off valve. If it is closed, open the valve.</p> <p>Check if the in-line strainer or valves are plugged. Clean them as needed.</p> <p>Check for proper wiring of humidifier cover interlock switch.</p> <p>Check if there is 24 VAC present at control board terminals 20 & 21. If yes, replace valve.</p> <p>Verify proper fill valve wiring.</p>

FAULT INDICATOR CODES

FAULT	MASTER (CODE)	SLAVE 1 (CODE)	SLAVE 2 (CODE)	SLAVE 3 (CODE)	DIGITAL DISPLAY READ-OUT
EEPROM FAILURE	SSSSL	LSSSL	SLSSL	LLSSL	"17) MASTER EEPROM" (Master control board programming failure) "18) SLAVE 1 EEPROM" (System B control board programming failure) "19) SLAVE 2 EEPROM" (System C control board programming failure) "20) SLAVE 3 EEPROM" (System D control board programming failure)
TRANSMITTER FAULT (Control)	LSLSL	none	none	none	"22) RH XMTR" (Control % RH humidity transmitter failure)
HUMIDISTAT OR SIGNAL BY OTHERS (Fault)	LSLSL	none	none	none	"22) RH STAT" (Humidistat or signal failure)
INPUT SIGNAL FAULT	LSLSL	none	none	none	"RH OUT OF RANGE"
TRANSMITTER FAULT (High limit)	SLLSL	none	none	none	"23) HL XMTR" (Control duct high limit % RH humidity transmitter failure)
TRANSMITTER FAULT (temperature)	LLLSL	none	none	none	"24) TMP XMTR" (Temperature compensation transmitter failure)
PROBE FAULT	SSSLL	none	none	none	"25) PROBE FAULT" (Water detection probe defective)
LOCAL DIGITAL DISPLAY FAULT	SSSSS	none	none	none	"1) LOCAL DISPLAY" (Communication failure to Local Digital Key Pad)
REMOTE DIGITAL DISPLAY FAULT	SSLSL	none	none	none	"21) REMOTE DISPLAY" (Communication failure to Remote Digital Key Pad)

FAULT INDICATOR CODES

POSSIBLE CAUSE	RECOMMENDED ACTION
Internal program changed (VAPOR-LOGIC detected a change from its previous program check)	Consult DRI-STEEM, for re-programming instructions
Incorrect placement of control boards, resulting in a switch of master and control boards (The system can only have a single "Master.")	Verify that the boards are placed correctly in the system.
Open, shorted, or incorrect wiring of transmitter or humidistat. Signal by others. Incorrect, out of range, or miswired.	Check D.C. supply voltage terminals: 5+, 7- (21 VDC)
	If there is no output 4-20 mA, replace.
	Recalibrate if there is a calibration error: Normal Range 4-20 mA = 0-100% RH 12 mA = 50% RH (Refer to Trim Adjustment on page 10 for further information.)
	Measure for normal 1-5 VDC range on Control RH transmitter or 4-20 mA by others: 6+, 7-.
	Measure for normal 1-5 VDC range on Duct High Limit transmitter: 9+, 10-.
	Measure 1-15 VDC: 6+, 7- signal by others.
	Measure 0-135 ohms, resistance: 6+, 7- signal by others.
Improperly located	Transmitter must be on inside window glass only. (See page 8 for correct placement.)
Incorrect transmitter wiring	Check D.C. supply voltage terminals 11+, 13- (21 VDC)
	Temperature transmitter -29°-71°C should have 12 mA = 21°C part #405889.
	Refer to Trim Adjustment on page 21 for further information.
Modular cable disconnected	Connect modular cables.
Reversed polarity of modular cable connection to cable plugs	See page 11 for correct polarity of the modular cable connection to cable plugs.
Key pad not configured as a remote	See page 19.
Electrical interference induced into key pad Control signal by others has exceeded the range limits. Correct control signal 4-20 mA, 0-135 ohms, 1-10 VDC	High voltage interference. Check routing of modulation cable.
	Remove key pad from within control cabinet.
	Noise spike induced into VAPOR-LOGIC board, check grounding of system, cabinet, humidifier, sensors.
Deterioration of probe rod assembly	Replace probe rod assembly.

TROUBLE-SHOOTING GUIDE

PROBLEM	POSSIBLE CAUSE	RECOMMENDED ACTION
CONTROL DOES NOT ENERGIZE	Non-existent supply voltage to unit	<p>Check main line fuse.</p> <p>Check main line safety switch.</p> <p>Check heater fuses.</p>
	Non-existent control voltage	<p>Check for proper supply.</p> <p>Verify proper transformer voltage characteristics.</p> <p>Verify proper wiring of transformer.</p> <p>Check for control circuit voltage, 24 VAC. If voltage is not present, check transformer circuit breaker. Reset if needed.</p>
	Heater over-temperature thermostat open (optional)	Reset manual switch located above heater.
UNIT DOES NOT FILL WITH WATER	Malfunctioning fill valve	<p>First, disconnect brown wire and then the orange wire from VAPOR-LOGIC board terminals 1 & 2 of terminal block J12. Fill valve should open.</p> <p>If fill valve does not open, verify proper 24 VAC (terminals 20 & 21) to fill valve. If voltage is present and valve does not open, replace valve or valve coil.</p> <p>Verify that coil is 24 VAC.</p> <p>Verify that valve stem moves freely.</p>
	No water supply to fill valve	<p>Check if water supply line strainer is plugged.</p> <p>Verify that manual water line shut-off valve is open and that pressure exists.</p>
	Improper slide switch setting on VAPOR-LOGIC control board	Set slide switch to "AUTO" mode.
	VAPOR-LOGIC control is in "end of season" drain mode	Check for humidity demand. (VAPOR-LOGIC control board terminals 5, 6 & 7 - Control Input 1 of terminal block J8.)
	Malfunctioning level control system	Verify that unit has new probe head design. If probe head does not have skirt extensions surrounding probe rods, it is an obsolete model and DRI-STEEM recommends replacement of probe assembly.

TROUBLE-SHOOTING GUIDE

PROBLEM	POSSIBLE CAUSE	RECOMMENDED ACTION
UNIT DOES NOT FILL WITH WATER (con't.)	Malfunctioning level control system (con't.)	<p>Disconnect brown and orange wires connected to VAPOR-LOGIC board terminals 1 & 2 of terminal block J12. If fill valve does not open, check for proper 24 VAC (terminals 20 & 21) to fill valve coil. If proper voltage is not present, the control board is defective.</p> <p>Check terminals 1, 2, 3 & 4 on VAPOR-LOGIC control board terminal block J12 for correct voltage: 3 (purple) to 4 (yellow), no water present > 2 VAC. 3 (purple) to 4 (yellow), water present < 1/4 VAC. 2 (orange) to 4 (yellow), same readings as above. 1 (brown) to 4 (yellow), same readings as above.</p>
FILL VALVE DOES NOT CLOSE	Open drain valve	<p>If automatic drain valve is locked in manual open position, reset to automatic.</p> <p>Replace valve if there is a broken return spring on the drain valve.</p> <p>Clean or replace drain valve if an obstruction in the valve will not allow complete closure.</p> <p>Close manual drain valve, if it is open.</p> <p>If VAPOR-LOGIC shorted output to fill valve coil, replace board.</p>
	Malfunctioning level control system	<p>Check if probe head is fully plugged in.</p> <p>If needed, clean probe rod tips.</p> <p>Verify that VAPOR-LOGIC control board terminal 4 is grounded.</p> <p>If there is low water conductivity, add salt to tank water. (If this solves the problem, consult DRI-STEEM for further advice.)</p> <p>Replace board if VAPOR-LOGIC control board is defective.</p> <p>Verify that slide switch is set to "AUTO" mode.</p> <p>Verify that probe is wired correctly.</p> <p>Check terminals 1, 2, 3 & 4 on VAPOR-LOGIC control board terminal block J12 for correct voltage: 3 (purple) to 4 (yellow), no water present > 2 VAC. 3 (purple) to 4 (yellow), water present < 1/4 VAC. 2 (orange) to 4 (yellow), same readings as above. 1 (brown) to 4 (yellow), same readings as above.</p>

TROUBLE-SHOOTING GUIDE

PROBLEM	POSSIBLE CAUSE	RECOMMENDED ACTION
FILL VALVE DOES NOT CLOSE (con't.)	Fill valve is stuck	<p>Check if fill valve is installed backwards. If yes, re-pipe.</p> <p>If there is a faulty internal spring or diaphragm in the fill valve, replace valve.</p> <p>Check if there is an obstruction that will not allow valve to seat properly. Clean or replace valve as needed.</p> <p>Check for control voltage across fill valve coil. (Check wiring and controls.)</p>
REDUCED OUTPUT OR NO OUTPUT (even though water level is proper)	Heater malfunctioning	<p>Verify that proper voltage is being applied to heaters.</p> <p>Check heater amperage.</p>
	Malfunctioning control system	<p>If heater contactor is not functioning, replace.</p> <p>Check if heater fuses are blown and replace if required.</p> <p>Check if auxillary limit controls are not allowing system to operate (i.e.: duct humidistats, air flow proving switch, etc.). Reset, replace or calibrate as needed. (Air flow switch, terminals 14 & 15, measures 24 VAC if open. On-off high limit, terminals 9 & 10, measures 21 VDC if open.)</p> <p>Check if the (optional) heater overtemperature thermostat has been tripped. Reset if necessary.</p> <p>Replace zone valve, if end switch is not closing.</p>
FILL VALVE CYCLES ON & OFF FREQUENTLY (several times per minute)	Malfunctioning level control system	<p>Verify that unit has the new probe head design. If probe head does not have skirt extensions surrounding probe rods, it is an obsolete model and DRI-STEEM recommends replacement of probe assembly.</p> <p>If needed, clean probe tips.</p> <p>Check water conductivity. (Minimum conductivity for proper operation of level control system is 100 micromhos per centimeter or 2 grains per gallon.)</p> <p>Verify that probe wiring is correct.</p>

TROUBLE-SHOOTING GUIDE

PROBLEM	POSSIBLE CAUSE	RECOMMENDED ACTION
FILL VALVE CYCLES ON & OFF FREQUENTLY (con't.)	Drain valve not fully closed	<p>If an obstruction will not allow drain valve to fully close, clean valve.</p> <p>If there is a broken or weak return spring on drain valve, replace the valve.</p> <p>Check if 24 VAC is present at valve. If so, reset VAPOR-LOGIC control board terminals 18 & 19.</p>
HEATER BURNOUT	Water level too low	<p>Check probes and clean tips if necessary.</p> <p>Clean probe still-well area in tank.</p> <p>Verify that unit has new probe head design. If probe head does not have skirt extensions surrounding probe rods, it is an obsolete model and DRI-STEEM recommends replacement of probe assembly.</p> <p>Check drain valve and clean, repair, or replace as needed.</p>
	Improper wiring	<p>Verify proper voltage applied to heater.</p> <p>Verify proper electrical connections.</p>
	Mineral build-up impeding heat transfer to water	<p>Inspect tank for severe mineral build-up on or around heater. Increase skimming quantity, frequency of drain cycle, and/or frequency of cleaning. Use softened make-up water.</p>
	Heater corrosion	<p>Inspect heater for surface corrosion or pitting. If evident, consult DRI-STEEM.</p>
NOISY OPERATION	"Thunder" type noise coming from tank during refill	<p>Normal on larger units, caused by the cold fill water collapsing steam in the tank. Reduce psi (minimum of 25 psi) if inlet water pressure is too high.</p>
	Contactor noise	<p>Contactors normally make a "clunk" as they pull in. A continuous chattering noise is not normal and is symptomatic of a failing contactor or malfunctioning controls. Replace contactor or troubleshoot the control system.</p>
	Fill valve noise	<p>A clicking sound as fill valve opens or closes and a hissing sound during fill are normal. A slamming sound as fill valve closes is "water hammer" and can be minimized by installing a shock arrester.</p> <p>A loud buzzing sound indicates poor alignment of valve stem. Replace valve.</p>

TROUBLE-SHOOTING GUIDE

PROBLEM	POSSIBLE CAUSE	RECOMMENDED ACTION
HUMIDITY BELOW DESIRED LEVEL	Unit operating but fails to meet required humidity output	<p>Unit undersized; replace with a larger unit or add additional humidifier.</p> <p>Skimmer rate is too high.</p> <p>If drain valve will not close fully, determine the cause and clean, repair or replace as needed.</p> <p>If drain pipe water seal is allowing steam to go down the drain, repair as needed.</p> <p>If there is an improper water seal height, increase to recommended height. (See humidifier O&M manual)</p> <p>If there is excessive internal steam pressure, determine the cause of the high pressure (i.e.: high duct static pressure, undersized orifices in dispersion tubes, water, or crushed vapor hose, etc.) and repair as required.</p> <p>Replace leaking gasket or vapor hose.</p> <p>Recalibrate if controls are out of calibration.</p> <p>If fill valve is stuck open, repair or replace.</p> <p>If zone valve will not open, repair or replace.</p>
	No call for humidity from humidistat or control and high limit humidity transmitters	<p>Low or no signal strength from humidistat.</p> <p>Check for proper wiring.</p> <p>Check humidity transmitters. (4-20 mA output)</p> <p>Adjust set point if VAPOR-LOGIC set point is too low.</p>
	Excessive outside air volume	<p>Verify proper operation of fans, dampers, VAV systems, etc.</p>
	Heating elements not operating	<p>If heaters are burned out, refer to previous section on HEATER BURNOUT.</p> <p>Humidistat calling for humidity (out of calibration.)</p> <p>Check for control voltage if limit controls (air flow proving switch, zone valves, etc.) are not allowing unit to operate.</p> <p>Check fuses and replace if they are blown.</p> <p>Check if the (optional) heater overtemperature has been tripped. Reset if necessary.</p>

TROUBLE-SHOOTING GUIDE

PROBLEM	POSSIBLE CAUSE	RECOMMENDED ACTION
HUMIDITY ABOVE DESIRED LEVEL (con't.)	Humidity control input type not the same as VAPOR-LOGIC software	Check VAPOR-LOGIC control board connections J9, J10 and J11. Consult DRI-STEEM.
HUMIDITY ABOVE SET POINT	High entering relative humidity	Dehumidify.
	Unit oversized	Consult DRI-STEEM.
	Reduced air flow	Check fans, dampers, VAV systems, etc.
	Improperly located humidistat or humidity transmitters	Relocate using guidelines established in this manual. (See page 5.)
	Malfunctioning controls	<p>Check for incorrect supply voltage.</p> <p>Check for incorrect control signal.</p> <p>Check for improper wiring hook-up.</p> <p>If humidity controller or transmitter are out of calibration or malfunctioning, repair or recalibrate.</p> <p>If zone valve end switch is not opening, repair or replace.</p> <p>If aquastat is malfunctioning and heaters are locked in, check for 24 VAC return from aquastat.</p> <p>Check if SCR shorted. Repair or replace as needed.</p>
HUNTING (humidity swings above and below desired set point)	Malfunctioning control system	<p>If there is a faulty or inaccurate humidity controller or transmitter, repair or replace.</p> <p>Check for proper VAPOR-LOGIC control settings: RH set point, HL set point, throttling range, cycle rate, delay time settings, PID tuning, etc.</p> <p>Relocate poorly located control components. (See humidity control placement drawing on page 5 for recommendations.)</p> <p>If inappropriate control components are being used, change components.</p> <p>If inappropriate control components are being used, change components.</p> <p>On SCR units: Control wire and power wires must be physically separated from each other. If they are not, an induced control voltage may occur, causing erratic operation.</p>

TROUBLE-SHOOTING GUIDE

PROBLEM	POSSIBLE CAUSE	RECOMMENDED ACTION
HUNTING (con't.)	Malfunctioning control system (con't.)	Verify that 4 wire modular cable is isolated from power wiring.
	Air volume varying rapidly	Stabilize.
	Air temperature varying rapidly	Stabilize $\pm 1^{\circ}\text{C}$.
UNIT DOES NOT PERFORM AUTO-DRAIN SEQUENCE	System may not have automatic drain system	Inspect unit to verify that automatic drain valve was furnished.
	Drain fault, plugged drain valve or plugged drain pipe	Clean drain valve piping.
	Malfunctioning auto drain sequence	Check VAPOR-LOGIC main menu settings and reset if necessary.
	No power to automatic drain valve	Check if 24 VAC is present at VAPOR-LOGIC control board terminals 18 & 19, and drain valve.
	Defective automatic drain valve	Valve should be replaced if voltage is present at valve and it still does not open.

REPLACEMENT PARTS

Figure 47-1:

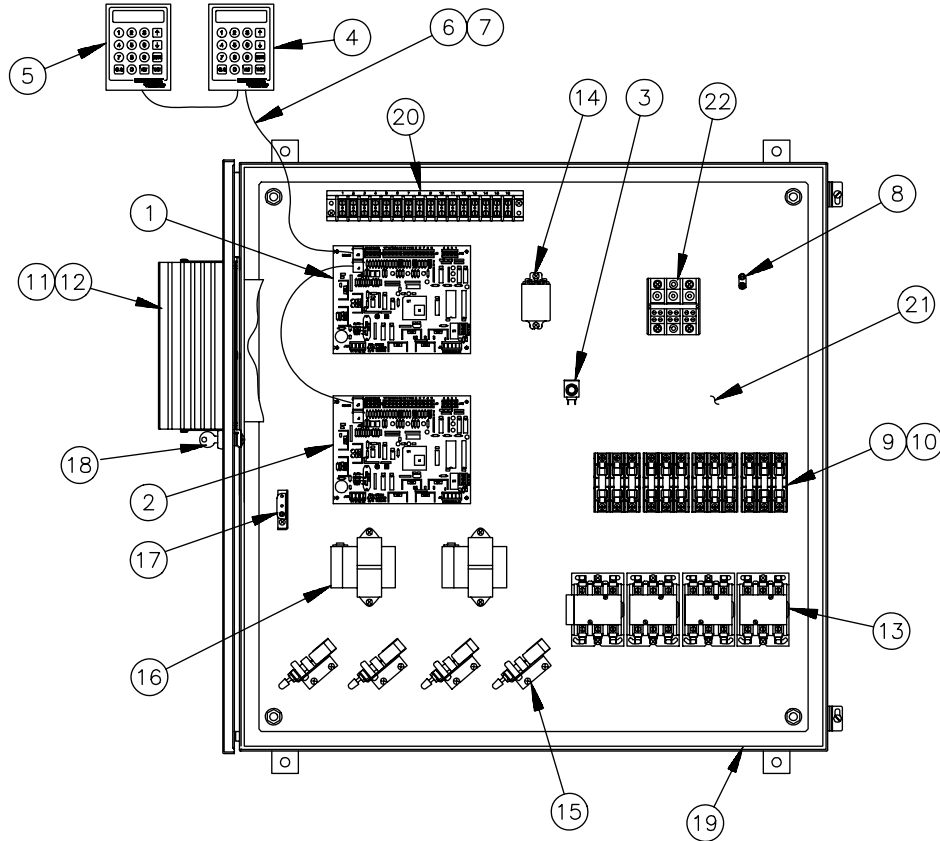

Table 47-1:

OM-347

No.	Description	Qty.	Part No.
1	Master Control Board	1	408640
2	Slave Control Board	1	408640
1 & 2	*Rebuilt Master/Slave Control Boards	1	408640-001
3	Reset Pushbutton (SPDT)	1	405888
4	Key Pad Digital Display Assembly "Local"	1	405890
5	Key Pad Digital Display Assembly "Remote"	1	405890
4 & 5	**Rebuilt Key Pad Display Assembly	1	405890-001
6	Cable 4 Wire		405885
7	Modular Cable Plug RJ11	1	405886
8	Ground Lug L-35	1	409250-017
8	Ground Lug L-70	1	409250-018
8	Ground Lug L-125	1	409250-019
9	Fuse Block 30 amp	1	407500
9	Fuse Block - 60 amp	1	406750-004
10	Fuse - 10 amp	1	406700-010
10	Fuse - 15 amp	1	406700-015
10	Fuse - 20 amp	1	406700-020
10	Fuse - 30 amp	1	406700-030
10	Fuse - 35 amp	1	406720-035
10	Fuse - 40 amp	1	406720-040
10	Fuse - 45 amp	1	406720-045
10	Fuse - 50 amp	1	406720-050
10	Fuse - 60 amp	1	406720-060

No.	Description	Qty.	Part No.
11	Slave SCR 50 amp, 480 V	1	408671-001
11	Slave SCR 50 amp, 600 V	1	408671-002
11	Slave SCR 70 amp, 480 V	1	408673-001
11	Slave SCR 70 amp, 600 V	1	408673-002
12	SCR Gasket - 50 amp	1	308411
12	SCR Gasket - 70 amp	1	308412
13	Contactors - 30 amp	1	407001-tab
13	Contactors - 50 amp	1	407001-tab
14	Relay DPDT	1	407900-001
15	Pneumatic/Electric Switch	1	408100
16	Transformer, 75VA, 230V/24V	1	408960-tab
16	Transformer, 75VA, 400V	1	408965-tab
17	Interlock Door Switch	1	408470
18	Keylock	1	700700
19	NEMA Cabinet	1	408150-tab
20	Terminal Block	1	408250-tab
21	Subpanel	1	
22	Power Block (310A)	1	407920
22	Power Block (175A)	1	407600
22	Power Block (85A)	1	408300-002
	2% Room Transmitter		405883-002
	2% Duct Transmitter		405884-002
	High Temp. Transmitter #T184H -29° to 71°C		405889

* Specify VAPOR-LOGIC program code when ordering control boards.

** Specify key pad advanced Firmware number, example - V2.04.

GLOSSARY

Algorithm: A series of computer software equations which instruct decisions to be made and calculation to be performed.

Alphanumeric: Pertaining to a character set that contains both letters and numbers and usually other characters.

Cable (Plenum Rated): A plenum or duct rated interconnecting electrical cable with twisted pairs of wires, including shielding and grounding wire. Cable used to reduce electrical interference into sensitive electronic components.

Cold Snap: See Temperature Transmitter.

Connector Shunt: A small plastic connector used to select type of control input on VAPOR-LOGIC® P.C. board.

Control Span: An output signal range where proportional action takes place. 6-9 VDC range typical for DRI-STEEM. An input signal range by others where proportional action takes place. (6-9 VDC range, 17-117 ohm range or 5-19 mA range typical for DRI-STEEM.)

Cycle Time: The time necessary (seconds) to complete a full on - through - off period in a time proportioning control system with contactors on solid state SCR power controller.

Delay Time: Time in seconds to energize or de-energize additional output stages.

Derivative: The control action to compensate for the rate or anticipatory change of the % RH.

Droop: A term used with proportioning controls. Refers to the difference between % RH (set point) and actual % RH values once the system stabilizes.

Digital Display: An alphanumeric Digital Display / Key Pad assembly allows user to review and change the control parameters.

EEPROM: Electronically Erasable Programmable Read Only Memory chip.

Error: The difference between the desired % RH (set point) and the actual % RH value reading.

Fault Relay: A SPDT relay mounted on VAPOR-LOGIC printed circuit board, energized when a fault condition is detected.

Firmware: Software programs and instructions that are stored in memory type IC chips.

Heartbeat/ Fault Indicator: An indicator lamp mounted on VAPOR-LOGIC printed circuit board to give visual information of system operating status.

High Limit Humidistat: A controlling humidistat that is mounted in a duct to prevent a high humidity level.

Humidistat: A controlling device that regulates and maintains a degree of humidity in % RH.

Humidity Transmitter: A monitoring device that senses the humidity level and provides an output signal based on humidity level and provides an output signal based on humidity level.

Integral: The control action that allows the proportional controller to adjust the % RH to the desired set point after the system has stabilized, eliminate droop.

Local Digital Display: Digital display / key pad identified as "LOCAL" module to VAPOR-LOGIC, no connector shunt on J6.

Main Menu: The main list of items to review or change the control parameters.

Microprocessor: The control and processing portion of VAPOR-LOGIC that handles arithmetic and logic.

P.I.D.: Proportional, Integral, Derivative. A control mode with three functions. Proportional action dampens system response, integral corrects for droop, derivative seeks to prevent overshoot and undershoot.

PE Switch: Pneumatic/Electric off-on switch, pneumatic input range 3-20 psi, preset pneumatic setting for electrical switch closure.

Prompt: An alphanumeric instruction displayed on the digital read-out directing you to perform an action to proceed with the VAPOR-LOGIC software.

GLOSSARY

Proportional Band: The range in which the VAPOR-LOGIC® system controls the proportioning function, expressed in percent of RH span.

Rate: See Derivative.

Reset: See Integral.

Remote Digital Display: Digital display / key pad identified as “REMOTE” module to VAPOR-LOGIC board and digital display / key pad.

Sample Interval: The specified time in seconds that the input/output values are sampled to evaluate and adjust the control function of P.I.D. control terms.

SCR Power Controller: A power regulating device that controls voltages and current to the heaters and includes a command signal board.

Scrolling: When VAPOR-LOGIC is in “Auto” mode, the digital module continually moves information across the digital display screen.

Software: The entire set of programs, procedures and related documentation associated with VAPOR-LOGIC system.

Sub-Menu: The point in the main menu where the parameters are reviewed and changed.

Temperature Transmitter: A monitoring device that senses the window glass temperature and provides an output signal based on the temperature level.

Range: -20 to 120°F part #405882 (model T184) used with firmware V1.01 thru V1.10.

Range: -2- to 160°F part #405889 (model T184-H) used with firmware V2.01 and higher.

Throttling Range: The span in % RH symmetrically around set point using digital display module and humidity transmitter or the control signal span from a humidistat where VAPOR-LOGIC time proportioning control action takes place.

VAV: Variable Air Volume system notation.

NOTES

TWO-YEAR LIMITED WARRANTY

DRI-STEEM Humidifier Company ("DRI-STEEM") warrants to the original user that its products will be free from defects in materials and workmanship for a period of two (2) years after installation or twenty-seven (27) months from the date DRI-STEEM ships such product, whichever date is the earlier.

If any DRI-STEEM product is found to be defective in material or workmanship during the applicable warranty period, DRI-STEEM's entire liability, and the purchaser's sole and exclusive remedy, shall be the repair or replacement of the defective product, or the refund of the purchase price, at DRI-STEEM's election. DRI-STEEM shall not be liable for any costs or expenses, whether direct or indirect, associated with the installation, removal or re-installation of any defective product.

DRI-STEEM's limited warranty shall not be effective or actionable unless there is compliance with all installation and operating instructions furnished by DRI-STEEM, or if the products have been modified or altered without the written consent of DRI-STEEM, or if such products have been subject to accident, misuse, mishandling, tampering, negligence or improper maintenance. Any warranty claim must be submitted to DRI-STEEM in writing within the stated warranty period.

DRI-STEEM's limited warranty is made in lieu of, and DRI-STEEM disclaims all other warranties, whether express or implied, including but not limited to any IMPLIED WARRANTY OF MERCHANTABILITY, ANY IMPLIED WARRANTY OF FITNESS FOR A PARTICULAR PURPOSE, any implied warranty arising out of a course of dealing or of performance, custom or usage of trade.

DRI-STEEM SHALL NOT, UNDER ANY CIRCUMSTANCES BE LIABLE FOR ANY DIRECT, INDIRECT, INCIDENTAL, SPECIAL OR CONSEQUENTIAL DAMAGES (INCLUDING, BUT NOT LIMITED TO, LOSS OF PROFITS, REVENUE OR BUSINESS) OR DAMAGE OR INJURY TO PERSONS OR PROPERTY IN ANY WAY RELATED TO THE MANUFACTURE OR THE USE OF ITS PRODUCTS. The exclusion applies regardless of whether such damages are sought based on breach of warranty, breach of contract, negligence, strict liability in tort, or any other legal theory, even if DRI-STEEM has notice of the possibility of such damages.

By purchasing DRI-STEEM's products, the purchaser agrees to the terms and conditions of this limited warranty.

DRI STEEM[®] **HUMIDIFIER COMPANY**

14949 Technology Drive • Eden Prairie, MN 55344
Telephone: 1-800-328-4447 • In MN: (612) 949-2415
Fax: (612) 949-2933 • E-Mail: sales@dristeem.com

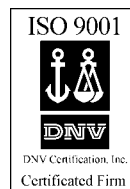

Printed on recycled paper with agribased inks minimum 10% post-consumer waste

