

DRISTEEM®

Vapor-logics®
Humidifier Control System

**Installation and
Operation Manual**



from the Humidification Experts

Table of contents

Overview

Product overview	1
Summary of features	2
Control input signals	3
TP modulation	5
SSR modulation	6
Valve and burner modulation	7
Water level control — standard water models	8
Water level control — DI/RO models	9

Installation

Installing the keypad/display	10
Main control board connections	11
GTS expansion board connections	15
Vaporstream expansion board connections	17
Installation checklist	18
Typical installation	19
General wiring procedures	20
Control cabinet connections	22
Sensor device placement and humidity control overview	25
Wiring sensor devices	26
Configuration string programming	32
Interoperability using LonTalk	34

Operation

Using the keypad	42
Menu structure overview	44
Main menu screens:	
Idle screen	45
Status screen	47
Control modes screen	48
Alarms screen	49
Fault messages	50
System Set Up screen	53
Adjusting set point	55
PID tuning	56
VAV, temp comp control operation	60
Dew point control, tank preheat operation	61
Aquastat, freeze protection operation	62
SDU/fan operation, sensor offsets	63
Automatic drain sequence (ADS)	64
End-of-season drain	66
Service interval, setting date and time	67
Diagnostics screen	68
Reports screen	69
Start-up checklist	71
Troubleshooting	74
Replacement parts	91
Warranty	Back cover

IMPORTANT

Read and save these instructions.

Product overview

Accurate, responsive microprocessor control

Vapor-logic3 provides comprehensive control for DRISTEEM humidifiers. With extensive capabilities and easy-to-use keypad, the Vapor-logic3 efficiently controls all humidifier functions.

Navigating the keypad to adjust or review humidifier functions is an intuitive process of walking through easily read screen menus.

You will find no other controller in the humidifier market able to provide such functionality, ease of use, and accurate relative humidity (RH) control.

Control options

- **On-off control:** Vapor-logic3 uses a humidistat to enable single-staged or multiple-staged electric outputs.
Expected accuracies: $\pm 5\%$ to 7% RH
- **Time proportioned (TP) control:** Vapor-logic3 directly reads space RH and uses a proportional, integral, derivative (PID) loop to vary the duty cycle of humidifier outputs to the solid state relay (SSR) power controllers or contactors.
Expected accuracies:
 - Contactor action: $\pm 2\%$ to 4% RH
 - SSR action: $\pm 1\%$ to 3% RH
- **Modulated control:** Vapor-logic3 directly reads space RH and uses a PID loop to control modulating steam or hot water valves (on STS or LTS) or GTS burners by providing a linear analog signal to the combustion air blowers.
Expected accuracies: $\pm 2\%$ to 5% RH
- **Control signal by others:** Vapor-logic3 accepts an analog control signal from another controller that directly determines the output of the humidifier.
Expected accuracies: Determined by external control system
- **LonTalk® interoperability:** Allows communication with a LonTalk building automation system using Standard Network Variable Types (SNVTs or “snivits”).

Summary of features

Summary of features

- **Self-diagnostic test at startup**
- **End-of-season autodrain**
- **Real-time clock** allows time-stamped alarm tracking and three ways to program drain and flush cycles:
 1. Usage (unit drains after a set number of pounds [kg] of water cycle through)
 2. Usage and interval (time) (unit drains at a preset time after a set number of pounds [kg] of water cycle through)
 3. At a preset interval (time)
- **Keypad** has a backlit display and features:
 - Intuitive menu-driven access to all system functions
 - Default screen for quick viewing of status and set points
 - Data reports to track performance and efficiency
 - System diagnostics and alarm tracking for troubleshooting
 - Password protection of setup parameters
 - Easy viewing in low light environments
 - Three ways to mount the keypad:
 1. Hand held (shipped with a 5' [1.5 m] cable)
 2. Mounted on the side of the control cabinet or humidifier shroud
 3. Mounted remotely using a standard telephone plate. The keypad can be located up to 500' (152 m) — the maximum length of the keypad cable — from the controller board and control cabinet.
- **Tank temperature sensor**, mounted on the evaporating chamber, allows Vapor-logic3 to provide:
 - Over-temperature protection (on some models)
 - Freeze protection
 - Tank preheating, allowing rapid response to a call for humidity
- **Sensitivity to low conductivity water** (important when using a standard humidification system with low mineral content water)
- **Single-controller platform; modular design**

The Vapor-logic3 controller is standard on most DRISTEEM humidifiers. The base configuration includes a main controller board and keypad. Expansion modules increase capability and allow DRISTEEM humidifier systems to use the same controller platform and keypad interface.

Control input signals

DRISTEEM offers three control options for all its humidification systems controlled by Vapor-logic3: on-off control, demand signal control, and transmitter control.

On-off control

On-off control—the simplest control scheme—does exactly what its name implies: the output device turns fully on, then fully off. Most residential furnaces use this type of control.

The humidistat that controls the humidifier has a differential between the on and off switch points. The differential is established at a range sufficient to prevent output short cycling. In other words, the humidity level has to fall below set point before the humidistat closes and energizes the humidifier. Once the humidifier is energized, the humidistat stays closed until the humidity is above set point. This creates an operating range that prevents the humidifier from running for very short periods of time.

In applications where there are multiple contactor outputs, such as a Vaporstream humidifier, contactors for each heat stage are pulled in one at a time with a one-second delay between them to prevent a brownout condition. In applications with a variable output stage, such as a GTS humidifier, the outputs are ramped up until they reach 100%.

Demand signal control

With demand signal control, the Vapor-logic3 controller provides the output level that a master control signal calls for. This signal can be generated either by a humidistat or by a building automation system. The signal sent to the Vapor-logic3 board is a modulating signal (typically 4 to 20 mA or 0 to 10 VDC). Vapor-logic3 responds to this signal by producing a direct proportional output. In other words, with a 4 to 20 mA signal, a command of 4 mA produces no output. A command of 12 mA runs the humidifier at 50% demand, and a command of 20 mA runs the humidifier at 100% demand. With a humidistat provided by DRISTEEM producing this signal, the humidity set point is set at the humidistat. The keypad/display then is used for maintaining and troubleshooting the humidification system, with humidifier control stemming from the humidistat itself. With a building automation system (BAS) providing the signal, the humidity set point is established by the BAS, and the humidifier responds to the BAS commands.

Control input signals, continued

Transmitter control

With transmitter control, the Vapor-logic3 board receives a linear signal that corresponds to the actual humidity level measured in the space being controlled. (With a transmitter provided by DRISTEEM, the signal is 4 to 20 mA, which corresponds to 0 to 100% RH). The Vapor-logic3 controller employs an internal PID loop that uses this humidity measurement along with a user-defined humidity set point to calculate a demand level. This demand level is the level at which the humidifier will run. For more information on the PID control loop, refer to Page 56.

TP modulation

TP modulation (electric humidifiers)

The standard form of modulation with an electric humidifier is time proportioning (TP) modulation. With TP modulation, the outputs cycle on and off at a certain rate to approximate humidifier demand as the example below illustrates. To calculate the example, imagine that each contactor represents 25% of the output of the humidifier. With a 55% system demand, you need two full contactors plus 5/25 of a third contactor. Therefore, two contactors are full on and a third contactor is on for 5/25 of 60 seconds, or 12 seconds.

Example

If a Vaporstream humidifier has four heat output stages (four contactors) and a demand of 55%, two of the contactors are energized all of the time; one contactor cycles on and off at a certain rate, and one contactor is off. The rate at which the third contactor cycles is determined by the demand and the heater cycle time. Continuing with the example, if you have a heater cycle time of 60 seconds and a demand of 55%, the third contactor cycles at a rate of 12 seconds on and 48 seconds off.

To minimize wear on cycling contactors, Vapor-logic3 keeps track of the number of cycles on all contactors, and rotates the TP cycling contactor to ensure that all contactors get equal wear. In addition, to prevent short cycling, no contactor has a cycle time less than two seconds or greater than the heater cycle time minus two seconds.

If system demand dictates that a contactor is on for less than a second, the contactor does not energize. If the contactor is on for between one and two seconds, the contactor energizes for the minimum two-second period. Also, if a contactor is de-energized for less than one second, it stays on. If a contactor is de-energized for between one and two seconds, the contactor de-energizes for the minimum two-second period.

These measures prevent short cycling of the contactors and extend their life. On a TP system with contactors, the heater cycle time is user adjustable and can be set from 30 seconds to 99 seconds (default is 60 seconds) via the Vapor-logic3 keypad/display.

TP modulation (gas humidifiers)

GTS burners provide TP modulation control when system demand is low. See Page 7 for more information about gas burner modulation.

SSR modulation

DRISTEEM electric humidifiers are available with two basic types of solid state relay (SSR) modulation: SSR modulation with contactors and 100% SSR modulation.

SSR modulation with contactor sequence

On systems that employ SSR modulation with contactors, the operation of the unit is the same as with TP modulation. In this scenario, one of the cycling contactors is replaced with an SSR. The SSR now is the device that carries out all of the cycling duties. The contactors are always either on or off. Any needed TP cycling is handled by the SSR stage.

This provides two distinct advantages over standard TP modulation. First, an SSR can turn on and off much faster than a contactor can. Therefore, as the unit modulates around a demand signal, tighter control is achieved because the cycle time on an SSR system can be as low as one second (factory set at two seconds). This means that every two seconds, the controller can adjust the on and off times of the SSR to closely track desired demand.

The second major advantage over standard TP modulation is reliability. With a solid state device like an SSR, component wear is almost nonexistent compared with an electromechanical device such as a contactor. Therefore, with the SSR doing all of the heavy cycling work, the life expectancy of the contactors is extended.

100% SSR modulation

The ultimate in electric humidifier modulation is 100% SSR modulation. With this type of control, all heat stages are controlled by SSRs. This allows the output of the humidifier to track the actual demand closely because all heat stages now can cycle on and off at the rapid SSR cycle rate.

With 100% SSR modulation, a contactor is wired in series with the SSR devices as an additional safety feature. If an SSR fails, the controller will de-energize the contactor, which will de-energize the heaters.

Valve and burner modulation

STS and LTS valve modulation

With a valve system, the demand signal simply determines how far the valve strokes. In other words, if the system demand is 25%, the valve strokes 25%.

GTS burner modulation

A GTS burner assembly consists of a variable speed blower, a constant air/gas ratio modulating gas valve, and a burner. The burner output modulates from its minimum capacity up to its full-rated capacity. To modulate the output, Vapor-logic3 controls the combustion air blower's speed. As the blower speed varies, the gas valve automatically adjusts the amount of gas introduced into the burner to maintain a constant air/gas ratio. This variable combination of gas and air results in clean combustion over the entire range of the burner capacity.

When system demand dictates that an individual burner must operate below its minimum output capability, burner operation changes from modulated to time proportioned (TP), meaning that the burner output is kept constant while it is on, but is cycled on and off. The burner cycle time is two minutes, and the burner on time is determined by the system demand.

To ignite the burner, the blower is run at a speed optimized for ignition to provide the smoothest, quietest, most reliable ignitions. If the tank is cold, the unit runs at 100% capacity to preheat the tank. Once the tank temperature rises above 190 °F (88 °C), the burner output is determined by system demand. In a multiple burner system, one burner is always operating when there is demand, while the other burners may or may not be operating depending on system demand. Once all burners are off, the ignition order reverses upon re-ignition to maintain even wear on combustion system components.

Water level control — standard water models

Figure 8-1:
Water level control for standard water systems

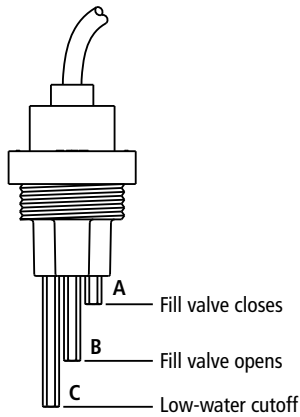

Systems using tap or softened water control water levels electronically using a three-rod probe. The controller responds with the above actions when the water level reaches each rod.

VLC-OM-030

Figure 8-2:
Water level control for standard water systems (on some older models)

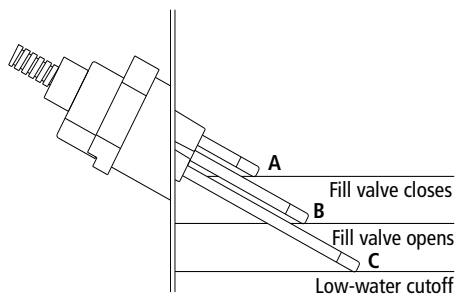

Systems using tap or softened water control water levels electronically using a three-rod probe. The controller responds with the above actions when the water level reaches each rod.

VLC-OM-030

Probe system

Standard or softened water systems use conductivity probes to measure and control water levels for optimum operating efficiency. Water conductivity must be at least 100 $\mu\text{S}/\text{cm}$ for the probe system to operate. The three-probe system is monitored by the Vapor-logic3 board, which performs all the necessary logic and timing functions to provide total water level control and safety shutdown.

Vapor-logic3 automatically maintains the water level between the upper two probes A and B (see Figures 8-1 and 8-2). When the water level falls below probe B, the fill valve opens until the water level reaches the upper probe A. Water must remain in contact with the probe surface for three seconds for Vapor-logic3 to determine that the water is at the probe's level.

Conversely, water must stay out of contact with the probe surface for three seconds for Vapor-logic3 to determine that the water is below the probe's level. This three-second delay ensures that turbulence does not cause an incorrect level reading.

Each time the fill valve energizes, the Vapor-logic3 system tests the probe system. If the signal from the probe assembly begins to deteriorate, the message "Clean Probes and Tank" appears on the keypad/display. Once the probe system reaches its maximum usable life, the humidifier shuts down and the "Probe Assembly fault" message appears.

An adjustable skim time allows for an extended skim period (0 to 120 seconds) to reduce surface mineral accumulation. When skimming, the fill valve remains energized after the water level reaches the upper probe A for the amount of time specified by the Skim Duration. The Skim Duration is adjustable in one-second intervals through the Set Up screen.

Probe C provides low water protection for the heating outputs. If the water level falls below probe C, the heating outputs are disabled.

Water level control — DI/RO models

Float valve system

DI/RO water systems (except for steam injection) use a float valve system to control water levels for optimum operating efficiency. DI/RO systems are used where water/steam purity is important, where demineralized water is needed to improve performance or lessen maintenance requirements, or where a potable water source has minimal or no conductivity, thus requiring a float rather than a probe to sense water levels.

The float valve system consists of a fill float and a low water cutoff float.

The fill float regulates how much water is added to the tank via a float ball, float arm, and mechanical valve. The valve is adjusted to fill the evaporating chamber within $\frac{1}{4}$ " (6 mm) of the overflow port allowing heated, and therefore expanded, water at startup to fill the external P-trap.

The low water cutoff float has an electrical switch that closes when a ready water condition is reached. A low voltage (0–2.3 VAC) current runs from the Vapor-logic3 controller to the switch allowing the controller to sense a ready water condition. This float switch provides low water protection for the heating outputs. If the water falls below the float, the heating outputs are disabled.

Vapor-logic3 uses the same three-second delay that is used with the probe system to determine whether water is in contact with the float.

CAUTION:

Damage caused by chloride corrosion is not covered by your DRISTEEM warranty.

Figure 9-1:
Water level control for DI/RO water systems

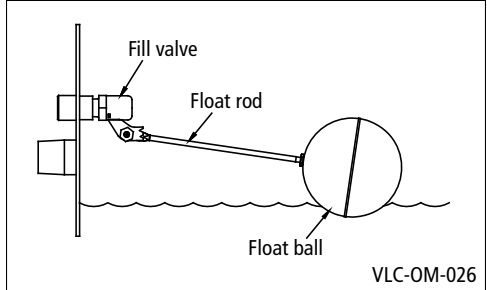

Figure 9-2:
Low water cutoff switch for DI/RO water systems

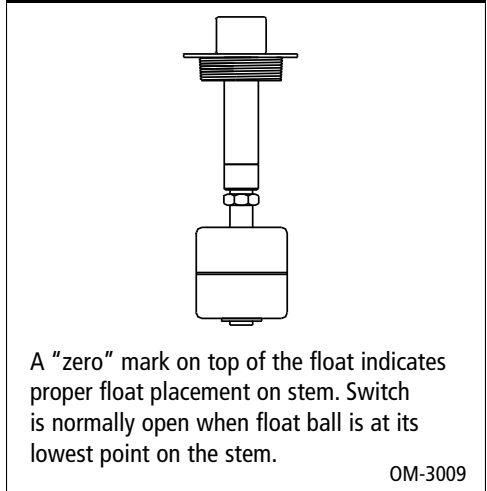
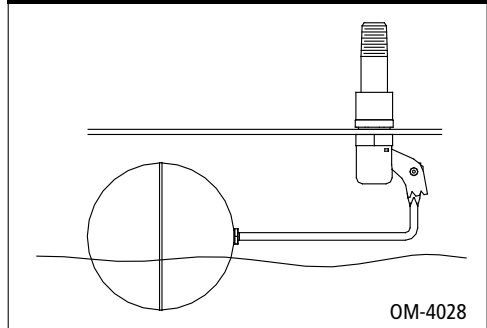

Figure 9-3:
Water level control for DI/RO water systems (Vapormist, Humidi-tech, CRUV)



Installing the keypad/display



IMPORTANT:

When routing modular cable inside the control cabinet, route cable away from all power wiring and connect the male modular plug into the Vapor-logics printed circuit board-mounted female modular receptacle, J2. Push the male plug in until you hear a "click." (The cable should be plugged into the keypad/display as well.)

CAUTION:

If a longer keypad cable is needed, do not fabricate one. Improper wiring can permanently damage the Vapor-logics board, keypad, or display. Contact your local DRISTEEM representative for longer cable options. The keypad cable can be up to 500' (152 m) in length.

Keypad/display installation

- **Installing modular cable**

The six-wire RJ-11 plug/cable provides AC power to the keypad/display and completes the FTT-10A digital communication between the keypad/display and the Vapor-logics control board.

- **Installing the keypad/display**

Note that the keypad/display requires an ambient temperature range of 32 °F to 122 °F (0 °C to 50 °C) to operate properly. Exceeding these limits can result in poor display performance and/or damage to the unit.

We recommend mounting the keypad/display to a surface using a field-supplied network phone wall plate (DRISTEEM part number 408490-017). To mount, slide the keypad/display onto the tabs on the phone plate.

Note: The Vapormist and Humidi-tech humidifiers ship with the keypad/display installed. An optional remote mount is available (DRISTEEM part number 4080491-007).

Main control board connections

**Figure 11-1:
Vapor-logic3 main control board**

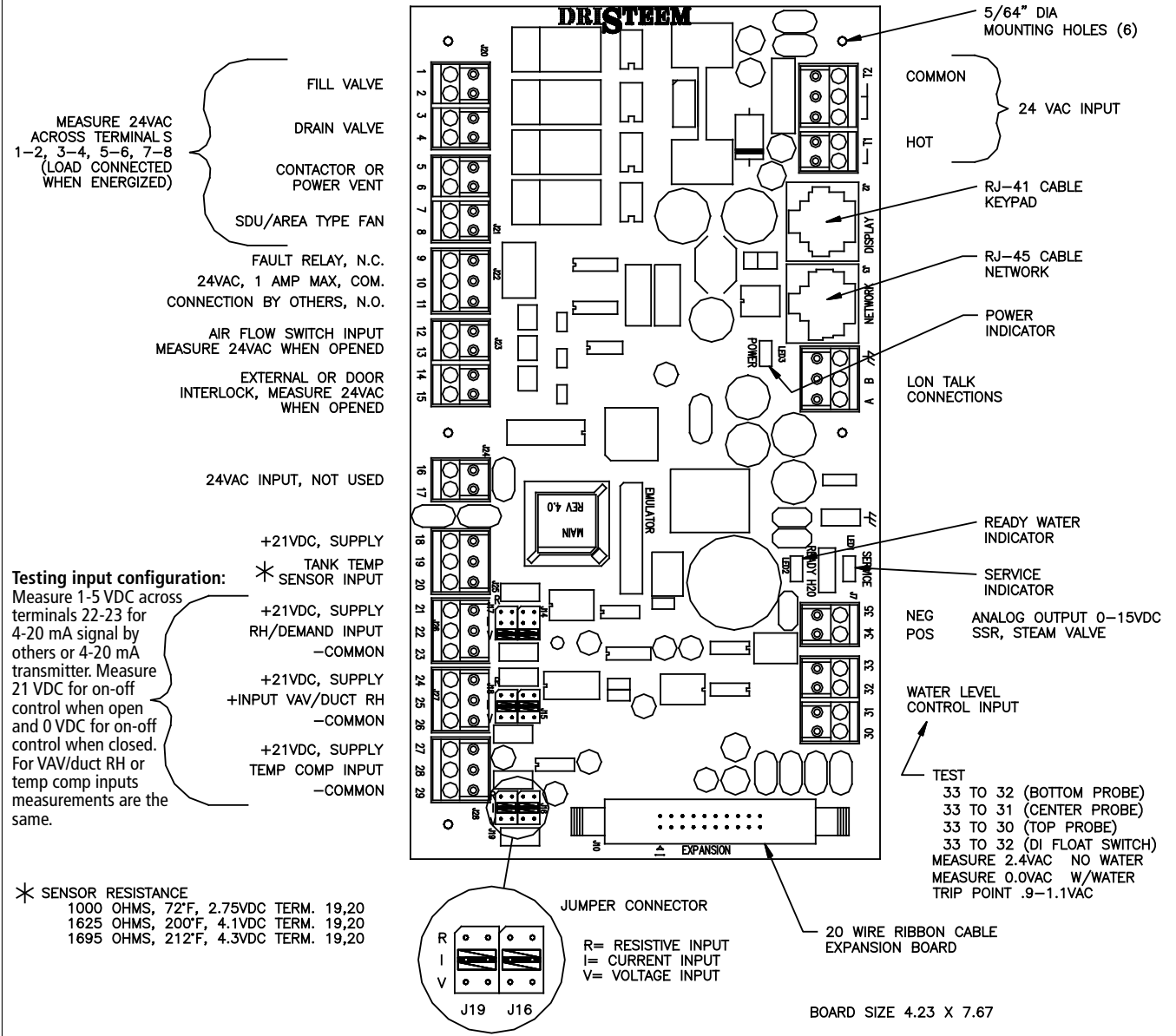

VL3-OM-010-2

Main control board connections

Vapor-logic3 main control board connections

- J1** Wire terminal supplies 24 VAC to power the Vapor-logic3 control board.
- Double terminal T1 to 24 VAC, 10 VA maximum load
 - Triple terminal T2 to 24 VAC common
- J2** RJ-11 female modular jack connection for supply voltage and FTT-10A communication to keypad/display
- J3** RJ-45 female modular jack connection for FTT-10A communication
- J4** Wire terminal connection for FTT-10A communication to LonTalk network. Terminals A and B provide the communication lines. The last terminal is earth ground for twisted pair wire shield.
- J5** End-of-line communication terminator pins
- J6** ¼" (6.4 mm) push-on connector for earth ground
- J7** 0 to 15 VDC analog output, typically connected to the input of a steam or hot water valve and 0 to 10 VDC digital output to solid state control (SSR). Terminal 34 is the positive output signal and terminal 35 is common.
- J8** Connector receives necessary continuity input signals from water detection devices:
- Standard water level detection (probe system)
 - Terminal 30 detects maximum water level from top probe rod and brown or black plug wire.
 - Terminal 31 detects water level at refill point from middle probe rod and orange or white plug wire.
 - Terminal 32 detects water level at its lowest point from lower probe rod and purple or red plug wire.
 - Terminal 33 is the common return path for all water detection rods from the humidifier tank machine ground back to Vapor-logic3 control.
 - DI/RO water level (float valve system)
 - Terminals 30 and 31 are not used.
 - Terminal 32 is connected to the humidifier tank low water float switch (normally open).
 - Terminal 33 receives the return signal from the float switch to Vapor-logic3 control via machine ground.
- J9** Not used
- J10** Ribbon cable connector for Vapor-logic3 expansion modules

Main control board connections, continued

Important note about J14/J17, J15/J18, and J16/J19

All external wiring connection diagrams show shunts on J14/J17, J15/J18, and J16/J19. The shunts and appropriate software are configured by DRISTEEM based on original customer orders. Field modification of these shunts requires control input modification: See Page 31, “Changing control input.”

J14/J17 These jumper pins determine the type of analog input signal that is read at the RH sensor input (terminals 21 through 23, terminal block J26). The three jumper positions are summarized below:

- R = Resistance, 0 to 150 ohm range
 - Used with on-off humidistats, staging switches, PE switches
 - Used with analog 0 to 150 ohm input devices (pneumatic transducer or humidistat)
- I = Current, 0 to 20 mA range
 - Used with any humidity sensor with 4 to 20 mA output
 - Used with any computer or building automation system with 4 to 20 mA output
 - Internal resistance is 249 ohms
- V = Volts DC, 0 to 15 volt range
 - Used with any DC voltage control signal, the default input signal is 0 to 10 VDC

J15/J18 These jumper pins determine the type of analog input signal that is read at the duct high limit RH input (terminals 24 through 26, terminal block J27). The jumper positions (R, I, and V) are identical to those specified for J14/J17.

J16/J19 These jumper pins determine the type of analog input signal that is read at the window temperature sensor input (terminals 27 through 29, terminal block J28). The jumper positions (R, I, and V) are identical to those specified for J14/J17.

J20 Wire terminal connector supplies 24 VAC control voltage to the fill valve via terminals 1 and 2 and to the drain valve via terminals 3 and 4.

J21 Wire terminal connector supplies 24 VAC control voltage to the power contactor (power vent relay on GTS) via terminals 5 and 6 and to the SDU or Area-type fan relay via terminals 7 and 8.

Figure 13-1:
Vapor-logics main control board detail

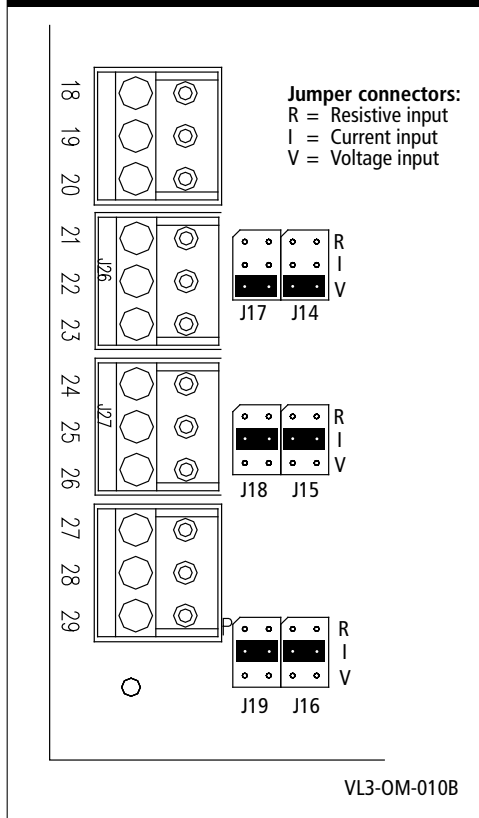

Main control board connections, continued

- J22** Wire terminal connection allows for remote fault indication via isolated relay contacts (1 amp max.). Terminal 10 is the isolated common connection; terminal 9 provides the normally closed connection, and terminal 11 provides the normally open connection.
- J23** Wire terminal connection provides optically isolated input connections for the airflow proving switch and safety interlock circuit. Terminal 12 supplies 24 VAC to the airflow proving switch (single pole, single throw [SPST]), which closes when airflow is present. Terminal 13 is the return connection from the switch into the Vapor-logic3 controller. Terminal 14 supplies 24 VAC to the safety interlock circuit (SPST), which is closed under normal operating conditions. Terminal 15 is the return connection from the safety circuit into the Vapor-logic3 controller. The humidifier is disabled when the safety interlock circuit is open.
- J25** Wire terminal connector provides input for the tank temperature sensor. The sensor is connected between terminals 19 and 20. Terminal 18 supplies 21 VDC and is not used.
- J26** Wire terminal connector reads the analog input signal from the controlling RH sensor or external demand source.
- Terminal 21: Positive polarity 21 VDC supply (25 mA max.)
 - Terminal 22: Control signal input
 - Terminal 23: Signal ground
 - Input selector pin J14/J17 configures J26 input
- J27** Wire terminal connector reads the analog input signal from the duct high limit RH sensor.
- Terminal 24: Positive polarity 21 VDC supply (25 mA max.)
 - Terminal 25: Control signal input
 - Terminal 26: Signal ground
 - Input selector pin J15/J18 configures J27 input
- J28** Wire terminal connector reads the analog input signal from the window temperature sensor.
- Terminal 27: Positive polarity 21 VDC supply (25 mA max.)
 - Terminal 28: Control signal input
 - Terminal 29: Signal ground
 - Input selector pin J16/J19 configures J28 input

GTS expansion board connections

**Figure 15-1:
GTS expansion board**

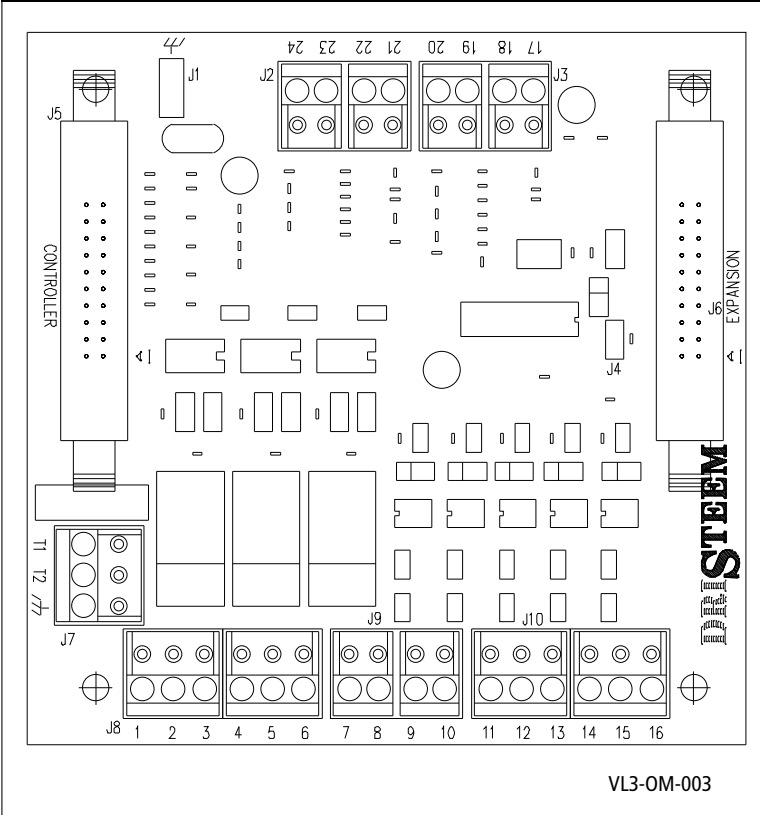

- J1 ¼" push-on connector for earth ground
- J2 Combustion air blower 2 control
 - Terminal 21: Positive polarity 21 VDC supply (25 mA max.)
 - Terminal 22: Blower tachometer feedback
 - Terminal 23: Pulse width modulation speed command to blower
 - Terminal 24: Common
- J3 Combustion air blower 1 control
 - Terminal 17: Positive polarity 21 VDC supply (25 mA max.)
 - Terminal 18: Blower tachometer feedback
 - Terminal 19: Pulse width modulation speed command to blower
 - Terminal 20: Common

GTS expansion board connections, continued

- J4 **Important:** When this jumper is left open, the GTS expansion module is configured to control burners 1 and 2. When jumped, the module is configured to control burners 3 and 4.
- J5 Ribbon cable connector for Vapor-logic3 main controller connection
- J6 Ribbon cable connector for additional Vapor-logic3 expansion modules
- J7 Wire terminal supplies 24 VAC to power the GTS expansion module.
- Terminal T1 to 24 VAC, 10 VA maximum load
 - Terminal T2 to 24 VAC common
- J8 Wire connection terminal for 24 VAC discrete outputs
- Terminal 1: Enables the ignition control module for burner 1 or 3
 - Terminal 3: Enables the ignition control module for burner 2 or 4
 - Terminal 5: Spare
 - Terminals 2, 4, and 6: Common
- J9 Wire connection terminal for optically isolated 24 VAC discrete inputs. Terminals 7 and 9 provide 24 VAC and are not used. Terminal 8 receives a 24 VAC feedback signal from gas valve 1 or 3. Terminal 10 receives a 24 VAC feedback signal from gas valve 2 or 4.
- J10 Wire connection terminal for optically isolated 24 VAC discrete inputs from the combustion air damper limit switch and power vent pressure switch. Terminal 11 supplies 24 VAC to the combustion air damper limit switch, which closes when the damper has opened. Terminal 12 is the return connection from the limit switch into the GTS expansion module. Terminal 13 supplies 24 VAC to the power vent pressure switch, which closes when the fan starts. Terminal 14 is the return connection from the pressure switch into the GTS expansion module. Terminals 15 and 16 are not used.

Vaporstream expansion board connections

- J1 1¼" (6.4 mm) push-on connector for earth ground
- J2 Not used
- J3 Ribbon cable connector for Vapor-logic3 main controller connection
- J4 Ribbon cable connector for additional Vapor-logic3 expansion modules
- J5 Wire terminal supplies 24 VAC to power the Vaporstream expansion module.
 - Terminal T1 to 24 VAC, 10 VA maximum load
 - Terminal T2 to 24 VAC common
- J6 Wire connection terminal for 24 VAC discrete outputs
 - Terminal 1: Enables the power contactor for heater stage 2
 - Terminal 3: Enables the power contactor for heater stage 3
 - Terminals 2, 4: Common
- J7 Wire connection terminal for 24 VAC discrete output
 - Terminal 5: Enables the power contactor for heater stage 4
 - Terminal 6: Common

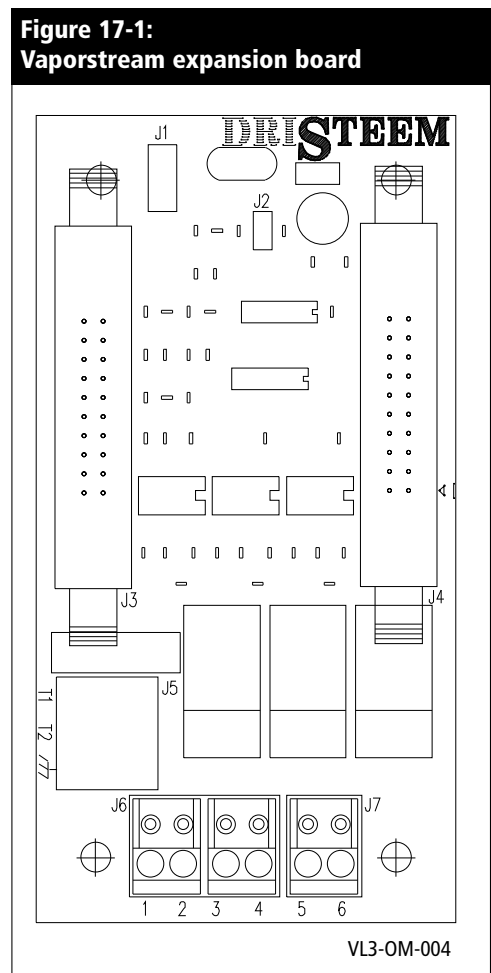

Installation checklist

Before installing your Vapor-logic3 control system, review this checklist to ensure proper installation of the product. Failure to follow the recommendations listed below could result in failure or damage to the humidifier or microprocessor.

- Before you start, read this manual and information.
- See wiring diagram and information located inside the control cabinet door. Return all information to the control cabinet after installation.
- Position the control cabinet so it is in sight of the humidifier tank and **the wire length from the control cabinet to the humidifier is 50' (15 m) or less.**
- Connect an approved electric earth ground to the earth ground lug in the control cabinet.
- Never route the low voltage field control wires near the line voltage section of the control cabinet or in the same conduit as line voltage wires.
- Never use shielded (screened) cable for water level probe and DI float switch wiring,** terminals 30 to 33.
- Connect the heater/machine ground lug, located in the junction box on the humidifier, to the subpanel machine ground lug with the appropriate wire, sized per the equipment grounding section of The National Electric Code (in Europe, IEC 60364 requirements).
- Use 2-wire, 18-gauge (1 mm²) shielded (screened) plenum nonconduit-rated cable with shield (screen) wire for all humidity and temperature sensor wiring. (See wiring diagram for appropriate connections.)
- Never ground shield (screen) wire at sensor end.** A shield (screen) grounding lug is provided on the control cabinet subpanel to ground the cable shield (screen) wire.
- Route keypad cable within control cabinet away from line voltage circuits.
- Verify that the Vapor-logic3 configuration string, detailed on Pages 32 and 33 of this manual, matches field requirements.**
- Follow the recommended control cabinet field conduit knockout locations shown on Page 23 and 24.

Typical installation

Figure 19-1:
Typical humidification system layout

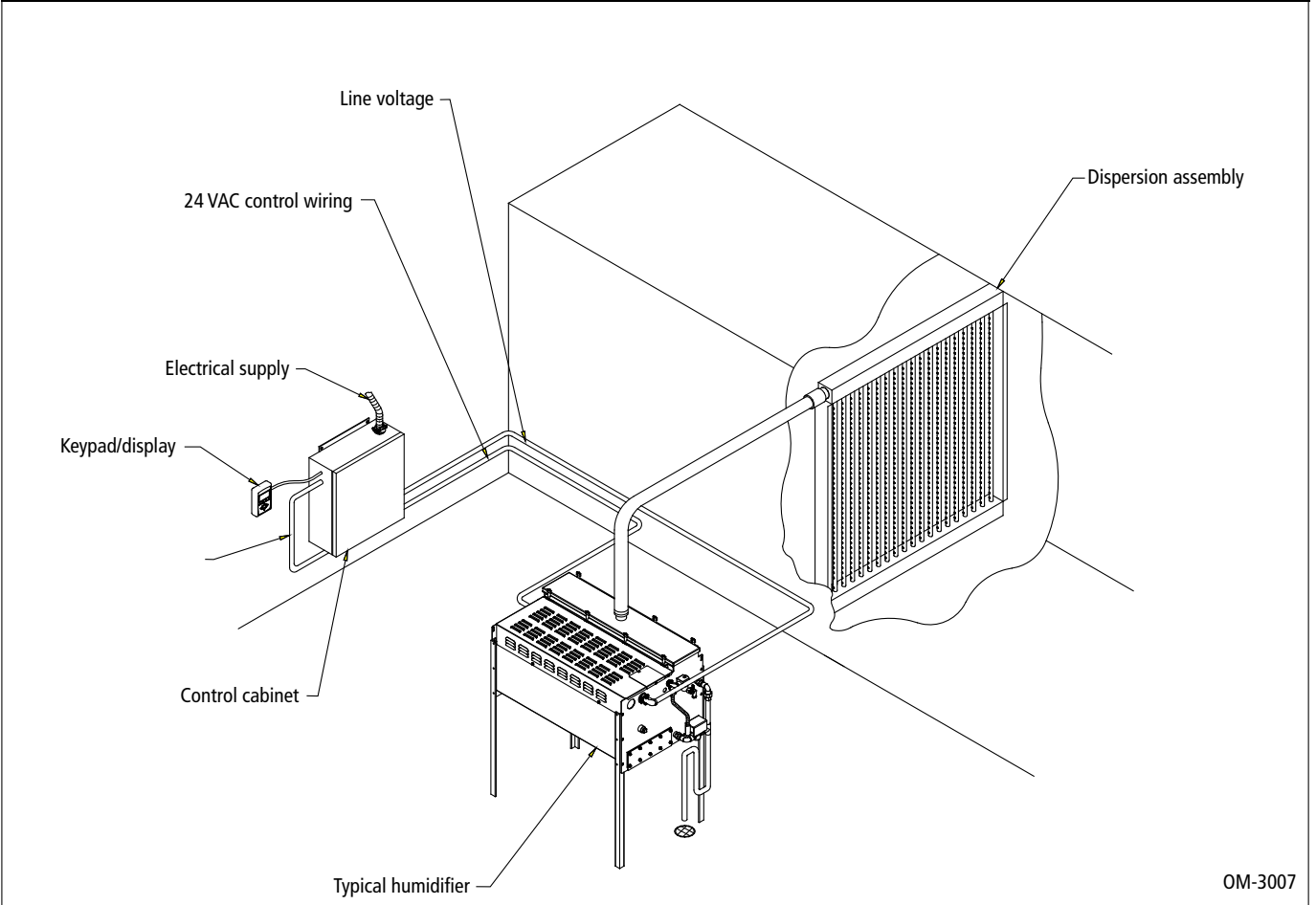

General wiring procedures

IMPORTANT:

Do not use shielded (screened) cable for probe wiring.

IMPORTANT:

Locate the control cabinet so that wire lengths are 50' (15 m) or less to the humidifier.

IMPORTANT:

When routing modular cable inside the control cabinet, route cable away from all power wiring and connect the male modular plug into the Vapor-logic3 printed circuit board-mounted female modular receptacle, J2. Push the male plug in until you hear a "click." (The cable should be plugged into the keypad/display as well.)

CAUTION:

When making penetrations in the control cabinet, protect all internal components from debris and vacuum out cabinet when finished. Failure to comply with this warning may damage sensitive electronic components and void the DRISTEEM warranty.

Proper wiring prevents electrical noise

Electrical noise can produce undesirable effects on electronic control circuits, thereby affecting controllability. Electrical noise is generated by electrical equipment such as inductive loads, electric motors, solenoid coils, welding machinery, or fluorescent light circuits. The electrical noise or interference generated from these sources (and the effect on controllers) is difficult to define, but the most common symptoms are erratic operation or intermittent operational problems.

Most noise problems can be prevented by using proper wiring practices and techniques to prevent coupling or inducing of electrical interference into control circuits. The following wiring practices should minimize interaction of noise and controls:

- Connect humidifier and control cabinets to a code-approved earth ground.
- Separate the line voltage wiring from the low voltage control circuit wiring when routing electrical wiring inside the control cabinet.
- Use separate electrical conduits for line voltage and low voltage control wiring from the humidifier to humidity sensors, airflow switches, etc.
- Do not use chassis or safety grounds as current-carrying commons. Safety grounds should never be used as a conductor or neutral to return circuit current.

General wiring procedures, continued

- When wiring external electrical connections to humidistats, room/duct humidity and temperature transmitters, or control signal input connections from a building control system, use 18-gauge (1 mm²) (minimum) plenum-rated, twisted-pair wire, with cable shield (screen) wire for grounding.
- Return all shielded (screened) cable connections to the control cabinet for grounding. Do not ground shield (screen) at the device end.
- Use 18-gauge (1 mm²) stranded wire run in conduit (see figure below) for probe and low water cutoff wiring.

Figure 21-1:
Vapor-logic3 probe wiring

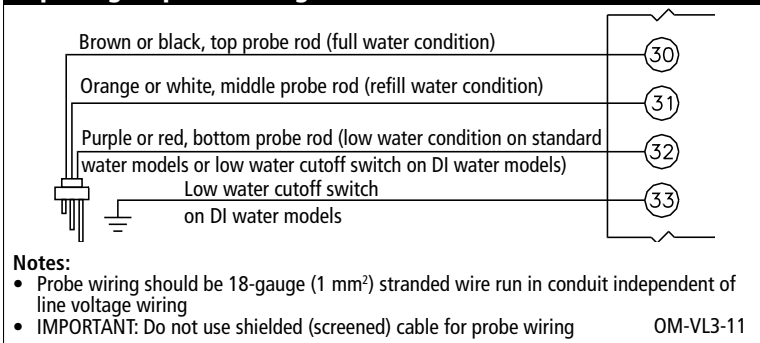

IMPORTANT:

Do not use shielded (screened) cable for probe wiring.

IMPORTANT:

Locate the control cabinet so that wire lengths are 50' (15 m) or less to the humidifier.

IMPORTANT:

When routing modular cable inside the control cabinet, route cable away from all power wiring and connect the male modular plug into the Vapor-logic3 printed circuit board-mounted female modular receptacle, J2. Push the male plug in until you hear a "click." (The cable should be plugged into the keypad/display as well.)

CAUTION:

When making penetrations in the control cabinet, protect all internal components from debris and vacuum out cabinet when finished. Failure to comply with this warning may damage sensitive electronic components and void the DRISTEEM warranty.

Control cabinet connections

Control cabinet installation and wiring

The Vapor-logic3 control board is shipped mounted with all internal wiring completed within a control cabinet. All software is custom programmed into your Vapor-logic3 system according to the original order requirements. Some control cabinets are factory mounted on the humidifier. Vapormist and Humidi-tech control components are located under the shroud.

Important control cabinet installation points

- All humidifier power wiring is represented on the humidifier wiring diagram located on the inside of the control cabinet door along with an installation guide. Return all instructions to the control cabinet after installation.
- Also refer to the Vapor-logic3 control board connection information on Pages 11–14 of this manual for detail of the board and connection points.
- If the control cabinet is not factory mounted, pick a location that allows easy access to the control cabinet and internal electrical components
- Mount control cabinet using the mounting tabs (unless cabinet is factory mounted or is integral to the humidifier).
- Always wire the Vapor-logic3 control board per governing codes.
- Vapor-logic3 is powered by a low voltage Class 2 control transformer. The transformer provides a 24 VAC supply and is protected by an integral manual reset circuit breaker.
- Follow field wire torque requirements shown on the electrical component or the electrical diagram provided with the humidifier when connecting the power and control wiring inside the humidifier control cabinet.
- Use only a 1/8" (3 mm) standard or ASC screwdriver on Vapor-logic3 control board terminal blocks.
- Use a single 18-gauge (1 mm²) pre-tinned wire in each terminal at the Vapor-logic3 terminal block. Torque to 4 inch-pounds (0.4 Nm).
- Do not terminate multiple wires to a single Vapor-logic3 terminal.
- Never run the control system wires bundled with, or in the same conduit as, power wires.

Control cabinet connections, continued

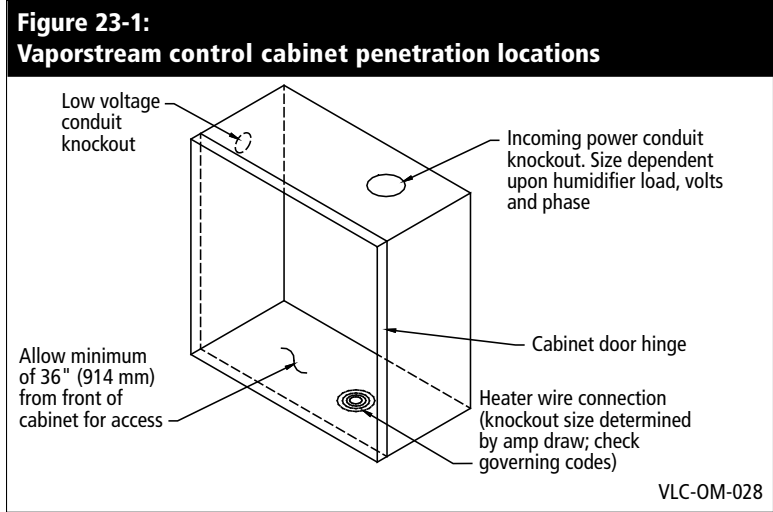

Vaporstream control cabinet

Standard control cabinets for VLC and VLDI are shipped loose. An available option is to order the cabinet mounted and wired to the humidifier.

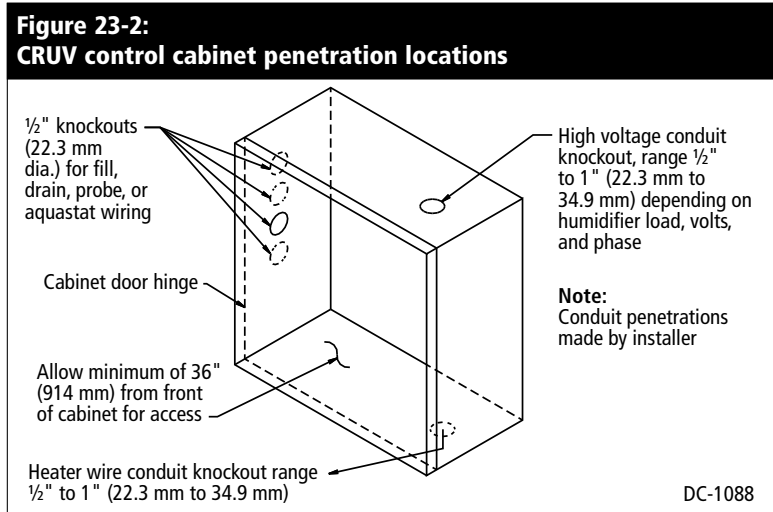

CRUV control cabinet

A prewired electric subpanel is available as an option, with or without a control cabinet.

CAUTION:

When making penetrations in the control cabinet, protect all internal components from debris and vacuum out cabinet when finished. Failure to comply with this warning may damage sensitive electronic components and void the DRISTEEM warranty.

Control cabinet connections, continued

STS and LTS control cabinet

Control cabinets for all STS and LTS humidifiers are shipped loose. An available option is to order the cabinet mounted and wired to the humidifier.

GTS control connections

GTS control components are an integral part of the GTS humidifier assembly. Knockouts are located on the front of the humidifier below the keypad. Conduit penetrations are made by installer. Choose the high voltage conduit location closest to power terminals.

CAUTION:

When making penetrations in the control cabinet, protect all internal components from debris and vacuum out cabinet when finished. Failure to comply with this warning may damage sensitive electronic components and void the DRISTEEM warranty.

**Figure 24-1:
STS and LTS control cabinet penetration locations**

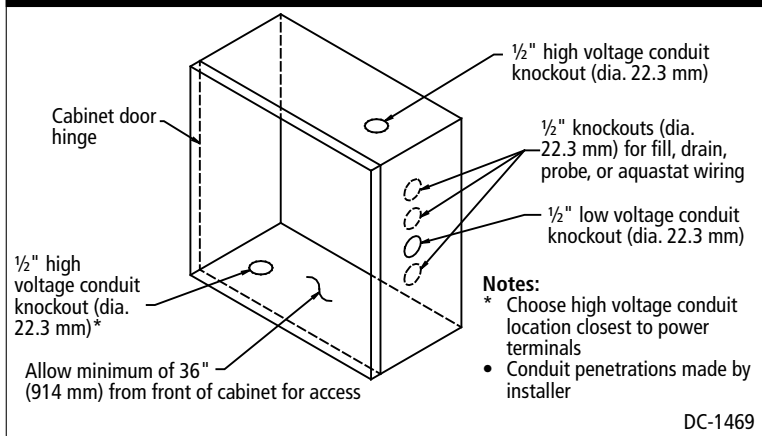

Sensor device placement and humidity control overview

Recommended sensor locations

Sensor or transmitter location has a significant impact on humidifier performance. In most cases, we recommend that you do not interchange duct and room humidity devices. Room humidity devices are calibrated with zero or little airflow; whereas duct humidity devices require air passing across them.

Recommended sensor locations (see figure below):

- A** Ideal—ensures the best uniform mix of dry and moist air with stable temperature control.
- B** Acceptable—room environment may affect controllability such as when sensor is too close to air grilles, registers, or heat radiation from room lighting.
- C** Acceptable—provides uniform mixture of dry and moist air, but if extended time lag exists between moisture generation and sensing, make sure control contractor extends sampling time.
- D** Acceptable—(behind wall or partition) for sampling entire room if sensor is near an air exhaust return outlet. Typical placement for sampling a critical area.
- E** Not acceptable—these locations may not represent actual overall conditions in the space.
- F** Not acceptable—do not place sensors near windows, door passageways, or areas of stagnant airflow.
- G** Best location for duct high limit humidistat or humidity sensor.

Other factors that affect humidity control

Unsatisfactory humidity control may involve more than the controller's capability to control the system. Other factors that play an important role in overall system control are:

- Size of the humidification system relative to load
- Overall system dynamics associated with moisture migration time lags
- Accuracy of humidistats and humidity transmitters and their location
- Dry bulb temperature accuracy in space or duct
- Velocities and airflow patterns in ducts and space environments
- Electrical noise or interference

Figure 25-1:
Recommended sensor location

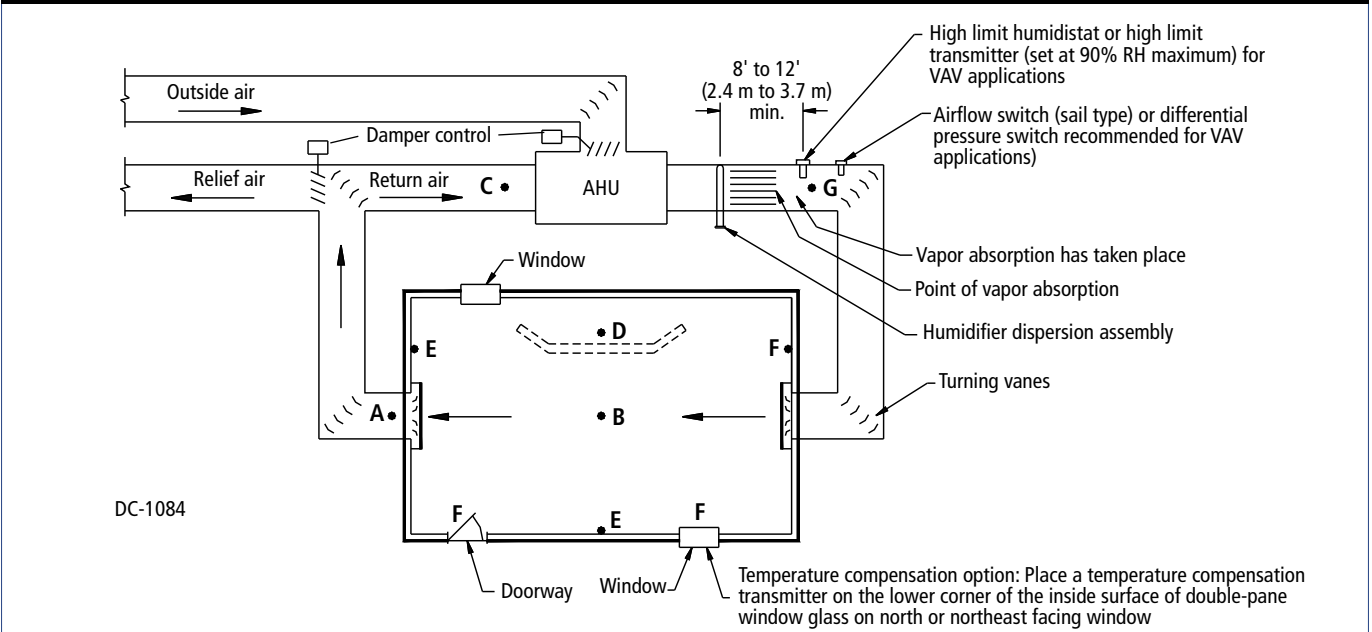

Wiring sensor devices

Figure 26-1:
Vapor-logics input wiring detail of a typical system configuration

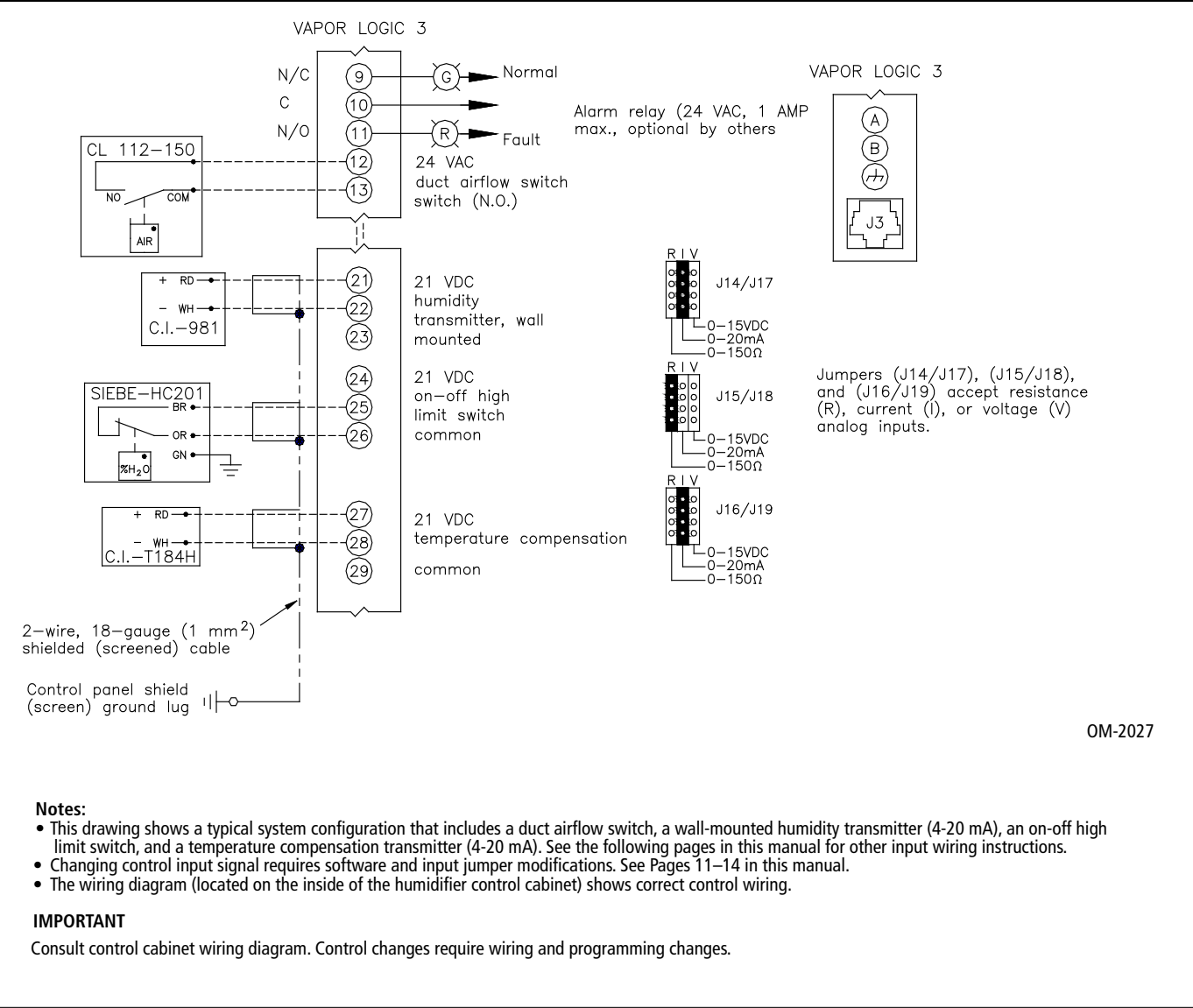

OM-2027

Notes:

- This drawing shows a typical system configuration that includes a duct airflow switch, a wall-mounted humidity transmitter (4-20 mA), an on-off high limit switch, and a temperature compensation transmitter (4-20 mA). See the following pages in this manual for other input wiring instructions.
- Changing control input signal requires software and input jumper modifications. See Pages 11-14 in this manual.
- The wiring diagram (located on the inside of the humidifier control cabinet) shows correct control wiring.

IMPORTANT

Consult control cabinet wiring diagram. Control changes require wiring and programming changes.

Installation: Wiring detail

Wiring on-off humidistats

DRISTEEM provides two types of on-off control: wall-mounted humidistat and duct-mounted humidistat. On-off control can also be achieved using a signal from another source, such as a building automation system (signal by others). The wiring diagram (located on the inside of the humidifier control cabinet) shows proper wiring for these controls.

Wiring modulating humidistats

When using modulating control, the signal from a humidistat directly controls the amount of output from the humidifier. The standard modulating humidistat controllers provided by DRISTEEM are either duct mounted or wall mounted.

The humidistats are powered by a 21 VDC supply provided by the Vapor-logic3 control board. A variable control signal from the humidistat modulates humidifier operation.

For a pneumatic modulating signal, DRISTEEM offers a transducer that accepts a 3 to 20 psi (21 to 138 kPa) pneumatic input range.

Wiring modulating humidity or temperature transmitters

Transmitters provide an analog signal proportional to the process variable being measured. All transmitters provided by DRISTEEM are two-wire devices. (See your wiring diagram for proper connections.) The humidity transmitters have a range of 0 to 100% RH with an output of 4 to 20 mA. The temperature transmitter has a range of -20 °F to 160 °F (-29 °C to 71 °C) with a 4 to 20 mA output.

Calculation of transmitter % RH

$$\% \text{ RH} = \frac{(\text{mA reading}) - 4}{0.16}$$

$$\text{Example: } \frac{12 \text{ mA} - 4}{0.16} = 50\% \text{ RH}$$

Figure 27-1:
Control humidity transmitter wiring

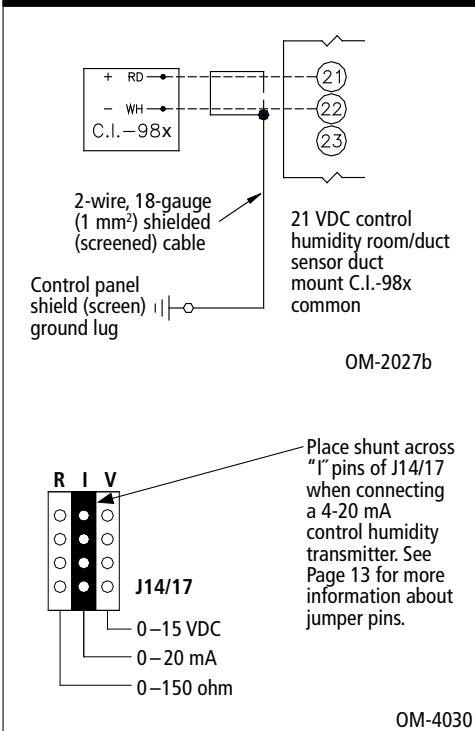

Wiring sensor devices, continued

**Figure 28-1:
VAV transmitter wiring**

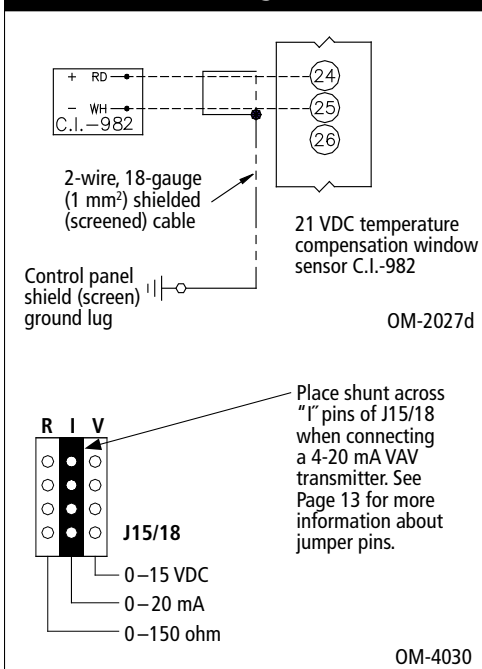

Variable air volume (VAV) option

This option is identified as a “V” in the third-from-last place of your program code configuration string (for example: EV11400285A7**V**OX). See Pages 32-33 for more information about the program code configuration string.

When the VAV control option is requested, DRISTEEM provides a duct mounted humidity transmitter (4 to 20 mA output, 0 to 100% RH range). Install using shielded cable (see Figure 28-1).

The modulating high limit transmitter signal operates in conjunction with the room or duct controlling transmitter signal through the Vapor-logic3 control system to prevent over humidification in the duct. Vapor-logic3 starts lowering the humidifier output when the duct relative humidity is within 6% of the duct high limit set point.

When this occurs, the message “VAV output limit” appears in the keypad/display. If necessary, the reduction of the humidifier output continues until maximum high limit set point is reached, shutting off the humidifier completely.

When the high relative humidity starts to decrease in the duct, Vapor-logic3 slowly starts to increase the production of steam vapor. When the duct relative humidity decreases to greater than 6% below the duct high limit set point, the control transmitter is restored as the primary controller, and the “VAV output limit” text no longer appears in the keypad/display, returning the control system to normal operation.

Wiring sensor devices, continued

Temperature compensation offset option

This option is identified as a “T” in the second-from-last place of your program code configuration string (for example: EV11400285A7OTX).

When selected as an option, DRISTEEM provides a temperature compensation (temp. comp.) transmitter. The temperature compensation transmitter continually monitors interior window glass temperature and transmits this temperature to Vapor-logic3.

Vapor-logic3 assumes a 70 °F (21 °C) room temperature and uses the glass temperature and the RH in the space being controlled to calculate the dew point (°F or °C) for the space.

If the window temperature falls below the dew point, Vapor-logic3 automatically decreases the RH set point so moisture does not form on windows. The Idle screen displays the modified RH set point, and an asterisk (*) appears next to the modified RH set point, denoting that temperature compensation has taken control of the RH set point. The “* Temp Comp” message appears on the status line. When the interior window glass temperature rises above the dew point, Vapor-logic3 restores system control to the normal RH set point for the space.

The transmitter provided with Vapor-logic3 is calibrated for –20 °F to 160 °F (–29 °C to 71 °C) with output from 4 to 20 mA. For example, a temperature reading of 70 °F (21 °C) should produce a measurement of 12 mA. You can calibrate the sensor by adjusting the Temp Comp Offset in the Set Up menu.

Install using an 18-gauge (1 mm²) plenum-rated shielded (screened) cable for transmitter wiring with grounding shield (screen) at the shield (screen) ground lug in the control cabinet (see Figure 29-1).

Figure 29-1:
Temperature transmitter wiring

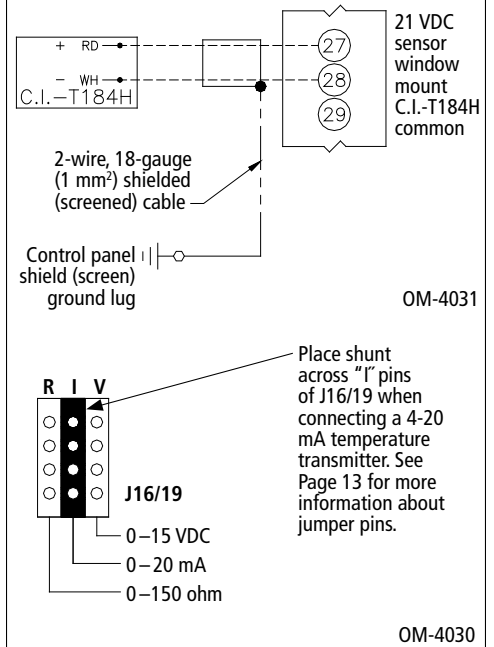

Wiring sensor devices, continued

Temperature compensation transmitter placement

To place the temperature compensation transmitter, follow these steps. See Figure 30-1 below.

1. Position the temperature compensation transmitter control box on a wall adjacent to a window frame facing north or northeast.
2. Place flat surface of temperature sensor tip on lower corner of glass surface.
3. Temporarily hold the sensor tip in place with strips of masking tape.
4. Apply a small amount of clear RTV silicone adhesive over and around the sensor tip (making sure the sensor tip is in contact with the window glass).
5. After adhesive cures, remove masking tape.

Figure 30-1:
Temperature compensation transmitter wiring

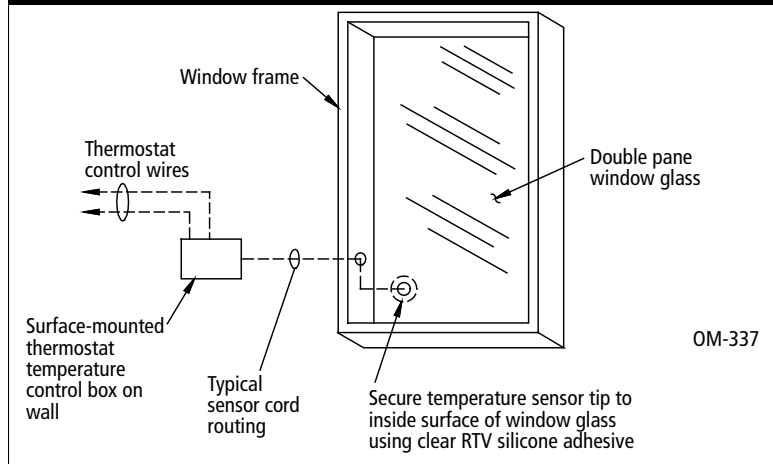

Wiring sensor devices, continued

Changing control input

You can configure the control input on the Vapor-logic3 board to read either an external demand signal or RH signal. It also can read different types of analog signals from building automation systems, humidistats, or RH transmitters. Follow these steps when a signal change is needed:

1. Remove the old signal wires from the control board (terminals 21, 22, and 23).
2. Refer to the configuration string text on Pages 32 and 33. Refer to: "K. Type of humidity sensing device" to identify the new signal that is needed.
3. Enter the Set Up menu on the Vapor-logic3 keypad and scroll to the Configuration String screen.
4. Change the last character in the configuration string to the desired input signal type identified from the configuration string information on Pages 32 and 33.
5. Adjust the shunt connector J14/J17 to the proper signal type, if necessary (see Page 13):
 - If the signal is electrical current, the jumper should be on I.
 - If the signal is voltage, the jumper should be on V.
 - If the signal is resistance or on-off, the jumper should be on R.
6. Connect the new signal wires to the board per the external connections diagram.

Figure 31-1:
Vapor-logic3 main control board detail

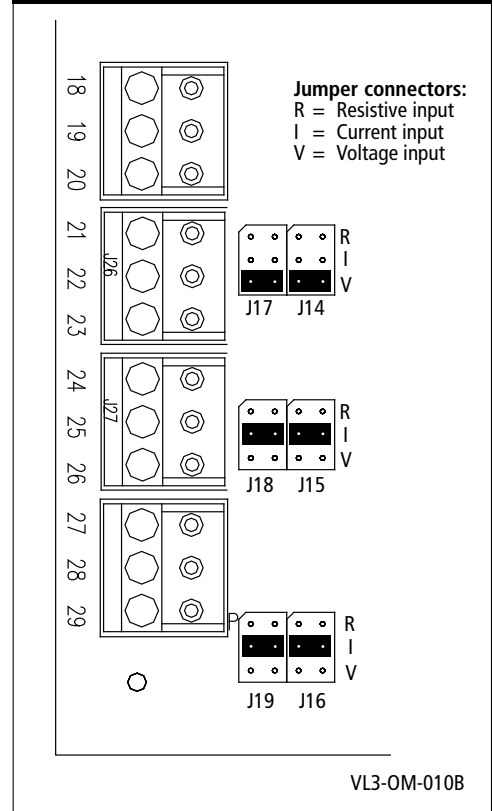

Configuration string programming

Configuration string explanation

A 15-digit Vapor-logic3 configuration string appears on the front of the control cabinet and on the wiring diagram inside the control cabinet. This string specifies the parameters of the Vapor-logic3 microprocessor that controls your humidification system. See the configuration string descriptions on this and the following page as well as the example string on the next page.

Vapor-logic3 configuration string

- A** Type of units:
 - E = U.S. English (inch-pound)
 - M = Metric (SI)
- B** Vapor-logic3 system type
 - G = GTS®
 - S = STS®
 - L = LTS®
 - V = Vaporstream®
 - M = Vapormist® (Humidi-tech®)
 - C = CRUV™
 - N = Steam Injection
- C** Vapor-logic3 board classification
 - 1 = One-tank system
 - 2 = Two-tank system
 - 3 = Three-tank system
 - 4 = Four-tank system
 - 5 = Five-tank system
 - 6 = Six-tank system
- D** Digital display/keypad features
 - 1 = Single keypad
- E** Number of heat stages (0 to 4)
 - 0 = Steam valve or 100% SSR (removed in version 3.01)
 - 1 = One heat stage
 - 2 = Two heat stages
 - 3 = Three heat stages
 - 4 = Four heat stages
- F** System pounds output
 - ##### = Output capacity
 - (e.g., 00285 = output capacity in lbs/hr [kg/h])
- G** Type of water level control
 - D = DI/RO, manual drain
 - E = DI/RO, end-of-season drain
 - F = DI/RO, end-of-season drain, normally open drain valve
 - X = DI/RO, autodrain, no end-of-season drain
 - M = Potable water, manual drain
 - A = Potable water, autodrain
 - B = Potable water, autodrain, normally open drain valve
 - Z = Potable water, autodrain, no end-of-season drain
 - S = Softened water, 1-minute drain every 28 days, end-of-season drain
 - T = Softened water, 1-minute drain every 28 days, end-of-season drain, normally open drain valve

Configuration string programming, continued

- H** Operating mode
 - 1 = Single staged
 - 2 = Externally staged
 - 5 = 100% SSR (added in version 3.01; string letter E identifies number of heat stage contactors when 100% SSR)
 - 6 = GTS
 - 7 = Time proportioning (TP)
 - 8 = SSR, SSR sequencing
 - 9 = Steam valve
- I** SDU and Area-type™ VAV options
 - V = Option present
 - O = Option not selected
 - S = SDU option
 - A = Area-type fan option
- J** Temperature compensation options
 - T = Option present
 - O = Option not selected
- K** Type of humidity sensing device
 - N = None, for on-off
 - C = 0 to 135 ohm humidistat or signal by others
 - D = 6 to 9 VDC humidistat or signal by others
 - H = 0 to 10 VDC humidistat or signal by others
 - E = 4 to 20 mA humidistat or signal by others
 - L = Demand signal via LonTalk
 - X = 4 to 20 mA transmitter
 - Q = Dew point transmitter
 - S = Special

Configuration string example

E	V	1	1	4	00285	A	7	0	0	X
---	---	---	---	---	-------	---	---	---	---	---

A	U.S. English units
B	Vaporstream
C	One-tank system
D	Single keypad
E	Four heat stages
F	285 lbs/hr (130 kg/h*) capacity
G	Potable water with autodrain
H	Time proportioning (TP) operating mode
I	No VAV option
J	No temperature compensation option
K	4 to 20 mA transmitter

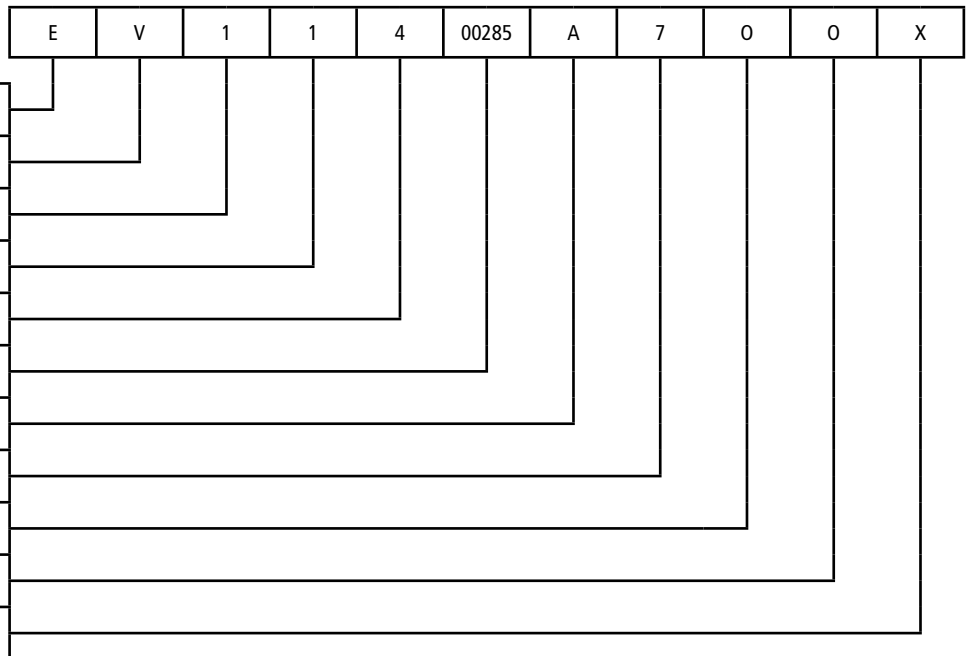

* Enter 00130 for kg/h

Interoperability using LonTalk

The Vapor-logic3 controller uses LonTalk as its field bus protocol, which enables previously disparate systems and products to interoperate by providing communication through Standard Network Variable Types or SNVTs (“snivits”). Any device can be installed on a network and logically connected to other devices via SNVTs as long as the SNVTs are the same type. The LonTalk twisted-pair network connection is made to Vapor-logic3 using the main board terminal block J4, labeled A and B (see Page 11).

A humidifier with Vapor-logic3 can communicate with various building automation systems (BAS) using LonTalk. This communication using SNVTs allows a BAS (or other device) to control and/or monitor a humidifier with Vapor-logic3. On the control side, a BAS connected to a humidifier with Vapor-logic3 can do things like set the run mode of the unit, change the RH set point, or tell the unit how much steam to make. On the monitoring side, a BAS can monitor alarm states of the unit, RH readings, tank temperature, steam output, and service information.

This section provides information on LonTalk inputs, outputs, and SNVT types used with Vapor-logic3, as well as connection instructions. For more information on SNVTs, refer to the LonMark SNVT Master List available from LonMark® at: <http://www.lonmark.org/products/snvtfile.htm>

Connecting LonTalk

Connect the keypad/display

Requirements: Lon network manager software (user should be proficient with the Lon network manager software).

Communication between the Vapor-logics main board and the keypad/display is via LonTalk with the keypad/display functioning as a LonTalk node. In order to use the keypad/display when the main board is under control of a network manager, the keypad/display also must be under network manager control and two bindings must be made. There are numerous Lon network managers and each has its own interface, but all network managers are able to commission devices and make bindings. Below is a connection example using LonMaker software.

Make network connection

Make the twisted pair network connection using terminal block J4, labeled A and B (see Page 11 for location).

Commission the main board and display

1. Drag and drop a “Device” from the upper left corner of the LonBuilder Basic Shapes palette to the LonMaker drawing window (see figure on the next page).
2. The New Device Wizard appears. In the External Interface Definition area, select “Upload From Device” as shown below.

Figure 35-1:
LonMaker New Device Wizard

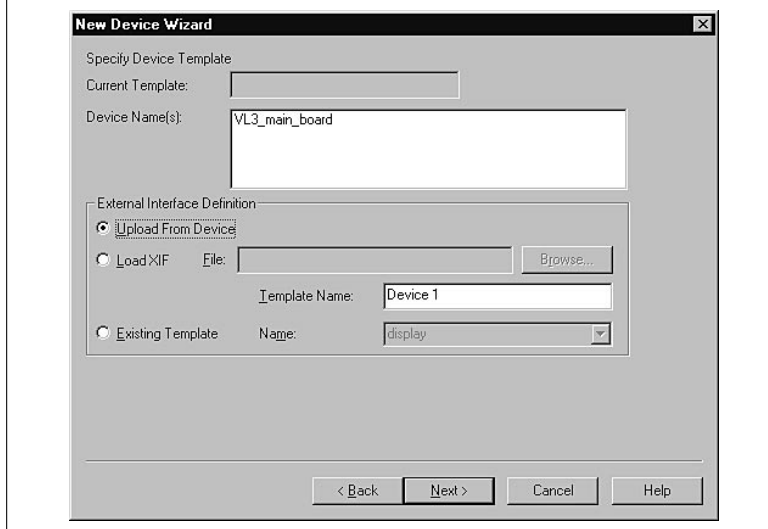

Connecting LonTalk, continued

Figure 36-1:
LonMaker example

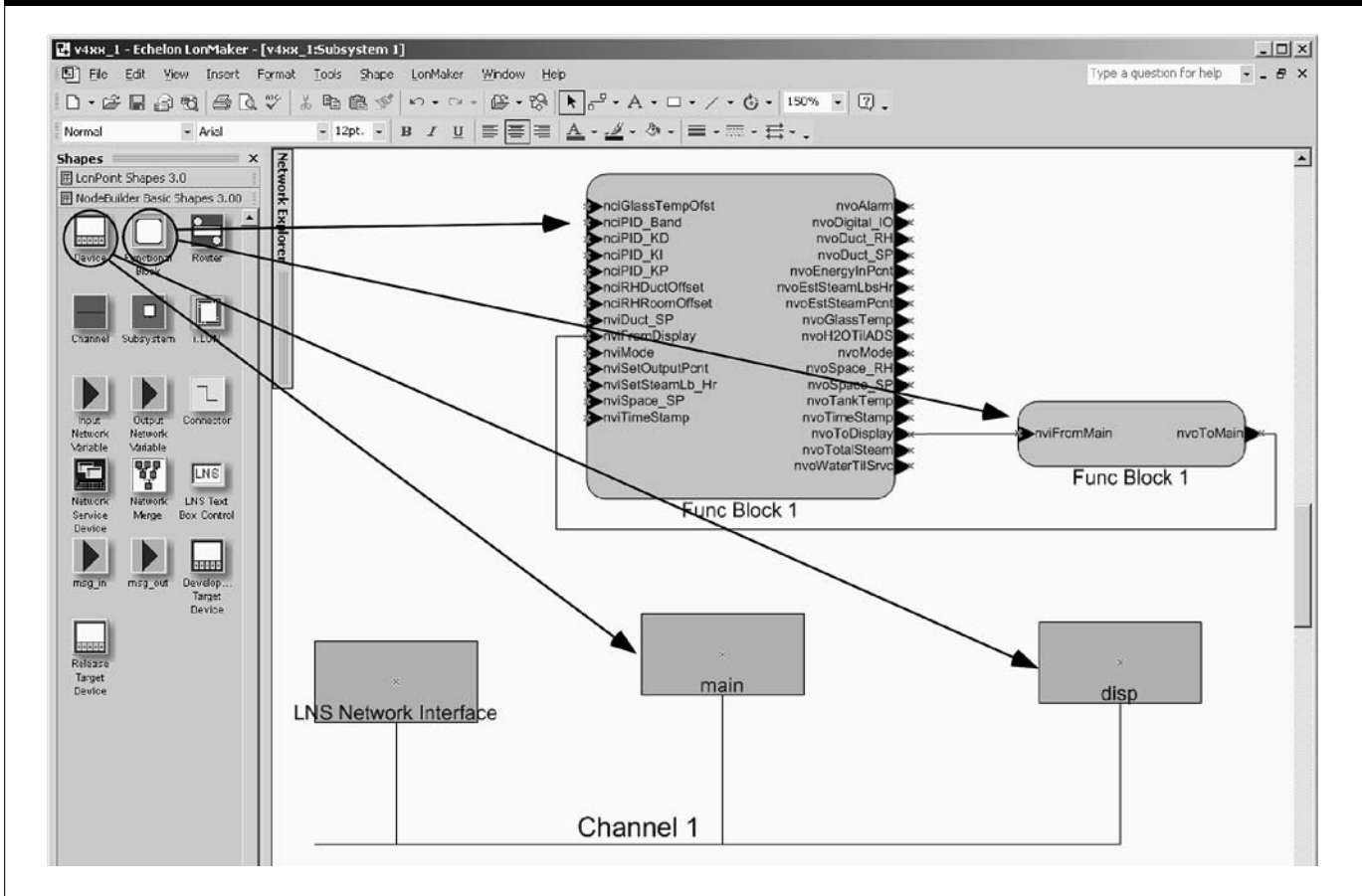

Connecting LonTalk, continued

3. If using the service pin to identify the board on the network, press the service pin (next to the blinking LED on the main board).
4. Repeat steps 1–3 for the display. The service pin for the display is an unmarked key on the keypad (see Figure 37-1).

Add a functional block

1. Drag and drop a “Functional Block” to the LonMaker drawing window (see figure on Page 36).
2. The New Functional Block Wizard appears. Select the name given to the main board device; then select the “Create shapes for all network variables” check box.
3. Repeat steps 1–2 for the display.

Bind main board and display

1. Drag and drop a “Connector Tool” to the drawing window in LonMaker and connect “nvoToDisp” from main to “nviFromMain” on the display.
2. Drag and drop a “Connector Tool” to the drawing window in LonMaker and connect “nvoToMain” on the display to “nviFromDisp” on the main.
3. To initiate communication between board and display, restart Vapor-logic3 by disconnecting and then reconnecting main power to humidifier.

Verify the Vapor-logic3 configuration string

See Page 53 for instructions on how to use the System Set Up menu to access and change the Vapor-logic3 configuration string. See Pages 32 and 33 for more information about the configuration string.

When the humidifier demand is controlled by others via LonTalk, the last position of the configuration string must be set to the letter **L** as shown in the following list of options for that position:

- N = None, for on/off
- C = 0–135 ohm humidistat
- D = 6–9 VDC humidistat
- H = 0–10 VDC humidistat
- E = 4–20 mA humidistat
- L = Signal demand by others via LonTalk**
- X = 4–20 mA transmitter
- Q = Dew point transmitter
- S = Special

Figure 37-1:
Display service pin and LED locations

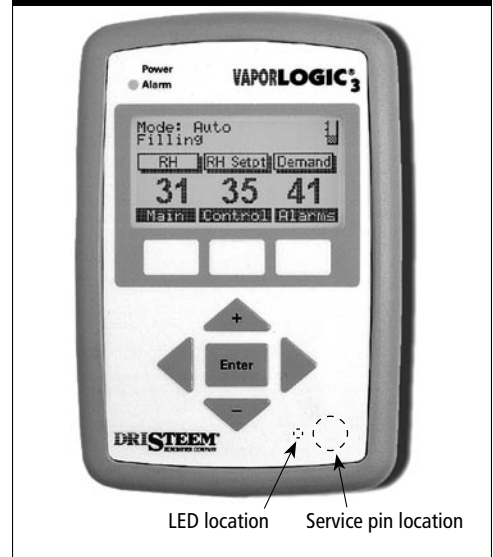

IMPORTANT

If you commission multiple humidifier systems within BAS control scheme and relocate any humidifier Vapor-logic3 control components within the system, you must decommission the component controls at their present location and then recommission them at their new location and name.

LonTalk Network variable and configuration inputs (nvi and nci)

**Table 38-1:
LonTalk network variable inputs (nvi) available with Vapor-logics**

nvi	SNVT	Description
nviTimeStamp	SNVT_time_stamp	Set the date and time of day.
nviMode	SNVT_count	Set the mode or current status of the humidifier. The defined options are: 1. Auto 2. Standby 3. Drain (manual)
nviSpace_SP	SNVT_lev_percent	Set the humidity set point for the space being humidified.
nviDuct_SP	SNVT_lev_percent	Set the duct high limit set point for VAV option.
nviSetOutputPcnt	SNVT_lev_percent	Set the steam output as a percentage of the humidifier's total capacity.
nviSetOutputLbHr	SNVT_count_inc	Set the steam output in pounds per hour. If the request exceeds the unit's capacity, the unit will run at 100% capacity.

**Table 38-2:
LonTalk network configuration inputs (nci) available with Vapor-logics**

nci	SNVT	Description
nciGlassTempOfst	SNVT_temp_diff_p	The temperature added to the measured window glass temperature (for sensor calibration). Whether the units are entered in °F or °C will depend on the localization of the Network Manager.
nciRHRoomOffset	SNVT_lev_percent	The amount (percent) added to the measured room (or space) RH (for calibration).
nciRHDuctOffset	SNVT_lev_percent	The amount (percent) added to the measured duct RH (for calibration).
nciPID_Band	SNVT_lev_percent	Allows network access to the PID band. See Pages 56–59 for more details about this value.
nciPID_KP	SNVT_count	Allows network access to the PID P gain. See Pages 56–59 for more details about this value.
nciPID_KI	SNVT_count	This allows network access to the PID I gain. See Pages 56–59 for more details about this value.
nciPID_KD	SNVT_count	This allows network access to the PID D gain. See Pages 56–59 for more details about this value.

LonTalk Network variable outputs (nvo)

**Table 39-1:
LonTalk network variable outputs (nvo) available with Vapor-logics**

nvo	SNVT	Description
nvoTimeStamp	SNVT_time_stamp	Read the current date and time that the unit is set to.
nvoMode	SNVT_count	Read the current mode of the unit. The defined options are: 1. Auto 2. Standby 3. Drain (manual)
nvoSpace_RH	SNVT_lev_percent	Read the relative humidity content of the air in the space being humidified (percent RH).
nvoSpace_SP	SNVT_lev_percent	Read the humidity set point for the space being humidified (percent RH).
nvoDuct_RH	SNVT_lev_percent	Read the relative humidity content of the air in the duct. Valid only when a duct mounted transmitter is installed.
nvoDuct_SP	SNVT_lev_percent	Read the humidity set point for the duct. This is the maximum RH that the unit will allow the duct to get to. See the "VAV control" section on Page 60 for more information.
nvoEstSteamPcnt	SNVT_lev_percent	Read the estimated amount of steam the humidifier is producing as a percentage of total capacity.
nvoEstSteamLb_Hr	SNVT_count	Read the estimated amount of steam the humidifier is producing in pounds per hour.
nvoGlassTemp	SNVT_temp_p	Read the window glass temperature.
nvoEnergyInPcnt	SNVT_lev_percent	Read the amount of energy being consumed as a percentage of the humidifier's total capacity.
nvoTankTemp	SNVT_temp_p	Read the temperature of the water in the humidifier's evaporating chamber.
nvoLbsH2OtilADS	SNVT_count	Read the pounds of water remaining to be converted to steam before the next automatic drain sequence (ADS) cycle.
nvoTotalSteam	SNVT_count	Read the pounds of water that have been converted to steam since this counter was reset.
nvoWaterTilSrv	SNVT_count	Read the pounds of water remaining to be converted to steam before the next service cycle.
More on the next page ►		

LonTalk Network variable outputs (nvoDigital_IO)

**Table 41-1:
Vapor-logics³ digital input states (nvoDigital_IO)**

Bit map position		0	1	2	3	4	5	6	7	8	9	10	11	12	13	14	15
Device		Airflow proving switch	External interlock switch	On-off high limit switch	SDU or Area Type fan control	For factory use only. Disregard states for these bit map positions											
State	0	No airflow	Open	Open	Fan off	X	X	X	X	X	X	X	X	X	X	X	X
	1	Airflow	Closed	Closed	Fan on	X	X	X	X	X	X	X	X	X	X	X	X
Example		0	1	1	0	0	0	0	1	0	0	0	0	1	0	0	0

Notes:

The 16-bit number, 0110000100001000, shown in the above example tells you that:

- There is no airflow at your airflow proving switch (State is 0 in bit map position 0)
- The external interlock switch is closed (State is 1 in bit map position 1)
- The on-off high limit switch is closed (State is 1 in bit map position 2)
- The SDU or Area Type fan is off (State is 0 in bit map position 3)
- Bit map positions 4–15 are for factory use only; disregard states in those positions. Not all humidification systems have the listed devices.

Using the keypad

Figure 42-1:
Vapor-logic3 keypad/display



Components of the keypad/display

The Vapor-logic3 keypad/display (see Figure 42-1) consists of :

- A 128 × 64 pixel backlit liquid crystal display (LCD)
- A power light
- An alarm light
- Eight keys:
 - Four arrow keys
 - An Enter key
 - Three soft keys

The three soft keys are located directly beneath the LCD. Each soft key's function is determined by the screen currently displayed. The function appears on the screen directly above each soft key.

Use the arrow keys to adjust the values of the different parameters or to navigate the blinking cursor on many of the screens.

Use the Enter key to make selections on various screens.

The power light illuminates whenever power is applied to the keypad/display.

The alarm light is activated any time a fault condition is detected.

Using the keypad, continued

The menu system

The Vapor-logic3 keypad/display organizes the control and monitoring of the humidification system into six top-level menus:

- Status
- Control Modes
- Alarms
- Set Up
- Diagnostics
- Reports

Each of these menus controls or monitors a different aspect of the humidifier. To access any of these screens, activate the Main Menu of the keypad by pressing the Main soft key whenever it is visible. This immediately takes you to the Main Menu selection screen. Select where you want to go by using the up and down arrow keys and by pressing the Enter key. The menu structure is diagrammed on the next page with a brief description of the submenus on the following pages.

Metric conversion

Vapor-logic3 can display all information in metric as well as English units. To change the current setting, modify the “type of units” in the configuration string accessed through the Set Up menu.

Menu structure overview

Main Menu

(Soft key) Idle

- (Soft key) **Main** – Returns to the **Main Menu** screen
- (Soft key) **Control** – Switches display to the **Control Modes** screen
- (Soft key) **Alarms** – Switches display to the **Alarms** screen

1 Status

- (Soft key) **Main** – Returns to the **Main Menu** screen
- (Soft key) **Back** – Scrolls to the previous **Status** item
- (Soft key) **Next** – Scrolls to the next **Status** item

2 Control Modes

1 Auto Mode

2 Test Mode

Test Status (only on Version 3.0.1 or greater)

- (Soft key) **Main** – Returns to the **Main Menu** screen
- (Soft key) **Back** – Returns to the **Control Modes** screen

3 Manual Drain

4 Standby

- (Soft key) **Main** – Returns to the **Main Menu** screen
- (Soft key) **Idle** – Switches display to the **Idle** screen

3 Alarms

- (Soft key) **Main** – Returns to the **Main Menu** screen
- (Soft key) **Info** – Displays the date and time the selected alarm occurred, along with more information on the alarm
- (Soft key) **Clear** – Clears the selected **Alarm** and keeps it in the alarm log
- (Note: Pressing Enter also displays the date and time occurred, along with more information on the alarm.)

4 Set Up

- (Soft key) **Main** – Returns to the **Main Menu** screen
- (Soft key) **Back** – Scrolls to the previous **Set Up** item
- (Soft key) **Next** – Scrolls to the next **Set Up** item

5 Diagnostics

- (Soft key) **Main** – Returns to the **Main Menu** screen
- (Soft key) **Back** – Scrolls to the previous **Diagnostics** item
- (Soft key) **Next** – Scrolls to the next **Diagnostics** item

6 Reports

1 H2O Converted

- (Soft key) **Main** – Returns to the **Main Menu** screen
- (Soft key) **Back** – Returns to the **Reports** screen
- (Soft key) **Reset** – Resets the report and flags when report was reset (only on Version 3.0.1 or greater)

2 Energy Used

- (Soft key) **Main** – Returns to the **Main Menu** screen
- (Soft key) **Back** – Returns to the **Reports** screen
- (Soft key) **Reset** – Resets the report and flags when report was reset (only on Version 3.0.1 or greater)

3 RH History

- (Soft key) **Main** – Returns to the **Main Menu** screen
- (Soft key) **Back** – Returns to the **Reports** screen
- (Soft key) **Reset** – Resets the report and flags when report was reset

4 RH Graph

- (Soft key) **Main** – Returns to the **Main Menu** screen
- (Soft key) **Back** – Returns to the **Reports** screen
- (Soft key) **Scale** – Toggles the time base of the RH history graph between the last 10 minutes, 1 hour, or 24 hours.

Main menu: Idle screen

Idle Screen

The Idle screen provides a convenient way to monitor the humidifier's basic operation. Depending on system options, the system set point, the actual space condition, and/or the system demand predominantly appear on the Idle screen.





The top line of the display shows the current mode of the humidifier: Auto, Test, Standby, or Manual Drain.

The second line is a system status line. This line continuously scrolls through current system status items. Depending on your system's options, this can include Filling, Skimming, No Duct Air Flow, or High Limit Disable. See Page 46 for a complete list. The soft keys provide quick, direct access to the Control Modes screen, the Alarms screen, or back to the Main menu screen.

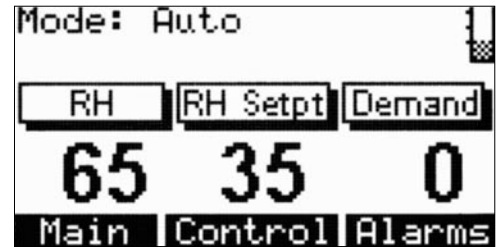
When the system is configured for potable or standard water, a tank-level indicator appears in the upper right corner of the screen. On potable or softened water systems, a three-probe system detects more information on the water level control system, see Page 8.

When water is in contact with all three sensing probes, the full tank graphic appears. When water is in contact with the bottom two probes, the mid level tank graphic appears. When water is only in contact with the bottom probe, the low level tank graphic appears. When there is no water in contact with any probes, the empty tank graphic appears.



-  Full tank
-  Mid level tank (fill cycle initiated)
-  Low level tank
-  Empty tank (heaters disabled)

Idle screen status messages

**Table 46-1:
Idle screen status messages**

Readout display	Description
Filling	The unit is filling with water.
Skimming	The unit completed a fill cycle and now is skimming.
Draining	The unit is draining.
Flushing	The unit is flushing.
No Duct Air Flow	The airflow proving switch is open and has disabled the humidifier (terminals 12 and 13).
Interlock Disable	The interlock circuit is open and has disabled the humidifier (terminals 14 and 15).
VAV Output Limit	The unit is approaching or has reached the duct RH high limit set point (terminals 24 and 25).
Preheating Tank	The unit received a call for humidity and is heating the tank at 100% until it reaches the water boiling set point.
Freeze Protection	The tank temperature has fallen below the freeze protection set point, and the unit is being heated to prevent the tank from freezing.
Aquastat Heating	The tank temperature fell below the aquastat set point, and the unit is being heated to maintain the aquastat set point.
End of Season Drain	The unit is in end-of-season drain mode.
End of Season	The unit is in end-of-season mode and is no longer draining.
Low Tank Level	The water level is below the probes on a standard water unit or below the float on a DI/RO water unit.
Temp Comp	The RH set point was temporarily modified to prevent moisture from forming on the windows. The modified set point is identified with an asterisk (terminals 27 and 28).
Duct RH High Limit	The duct high limit RH was reached and disabled the humidifier (terminals 25, 26).
Service Humidifier	It is time to perform routine service on the humidifier. See page 67 to clear.
Clean Probes & Tank	The system detected the need to clean the tank and water level probe assembly to prevent false water level readings.

Main menu: Status screen

Status

Use the Status screen to view the operating parameters of the humidification system. The configuration string determines which parameters appear. The parameters that can appear are listed below:

- RH Setpoint
- Room RH
- Dewpoint Setpoint
- Measured Dewpoint
- Duct Setpoint
- Duct RH
- Window Temp
- System Demand
- Stage 1 Demand
- Stage 2 Demand
- Stage 3 Demand
- Stage 4 Demand
- System Output
- Tank Temp
- Water til ADS
- Water til Service

See Page 53 for descriptions, ranges, and default settings for these parameters.

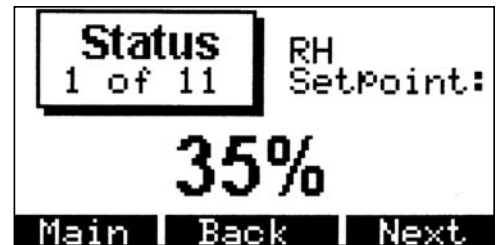

Main menu: Control modes screen

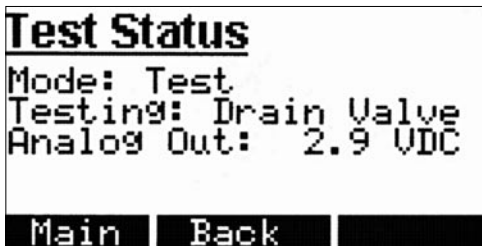

Control modes

Use the Control Modes screen to set the operational mode of the humidifier. You can choose from auto, test, standby, or manual drain.

In Auto Mode, the humidifier operates normally. All inputs and outputs are monitored and controlled. If there is a call for humidification, the system reacts.

In Test Mode, the controller sequentially cycles on each of the 24 VAC outputs for four seconds (30 seconds for the drain valve) so that their operation can be confirmed. The analog output linearly ramps from 0 to 10 VDC and back to 0. If the unit is a GTS, the combustion air blowers also are ramped up and down. Once all outputs are cycled on and off, the controller reverts to the Standby mode.

When the unit is in Test Mode, the Test Status screen appears. The Test Status screen displays which output is being actuated and displays voltage level at the analog output. If the unit is a GTS, the blower tachometer value also appears. The Test Status screen also displays the current mode of operation. Press the Back key to return to the Control Modes screen. Press the Main key to return to the Main Menu.

In Standby mode, the humidification system is taken off line. All humidity control inputs appear but are not acted upon; however, if the tank temperature falls below the freeze protect set point, the drain valve opens.

In Manual Drain mode, the automatic drain valve (if so equipped) opens and the tank drains. All humidifier operation is suspended, and the drain valve remains open until the unit is taken out of Manual Drain mode.

To select a new mode, use the vertical arrow keys to move the selection pointer on the left side of the screen up or down. When the pointer is positioned next to your new selection, press Enter. Your new selection now appears as highlighted text.

Note: The current mode of the humidifier always appears as highlighted text on this screen.

Main menu: Alarms screen

Alarms screen

Use the Alarms screen to clear system alarms and to view the alarm log. To scroll through the alarm log, use the vertical arrow keys.

The alarm log contains a record of the previous 10 faults (alarms) that occurred on the humidifier. The first column displays the alarm name. The second column displays the status of the alarm.

When viewing the alarm log, only the first alarm (which is highlighted) is active. All other alarms listed in the log occurred in the past and are cleared. To scroll through the alarms, use the up and down arrow keys.

If you want more information on any alarm in the log, select that alarm using the arrow keys and press either the Info soft key or Enter. A screen appears with the date and time the alarm occurred as well as a more detailed explanation of what the alarm means.

To clear an alarm, press the Clear soft key. The alarm is cleared but remains in the alarm log for future reference.

Note: Power loss clears the alarm log.

If more than 10 alarms occurred since the unit was powered, the oldest alarms are removed from the alarm log first.

For more information about alarms and actions to take, see the troubleshooting section in this manual.

Alarm 1	Status	
LL Probe Fault	Active	
Main	Info	Clear

```
LL Probe Fault
7/30/02 at 17:47:54
Mid and/or high level
received without low
level
Back
```

Fault messages

Tank level fault (previous name: Fill Time Fault)

The Vapor-logic3 controller keeps track of how much water converts to steam. If this total amount exceeds a preset limit without energizing the fill valve, the controller assumes a low water condition is present. This shuts down the humidifier and logs a tank level fault. The humidifier will not resume operation until you clear this fault. Each time the fill valve energizes, the total is reset to zero.

Except on systems equipped with end-of-season draining capability, the controller cannot keep track of water usage on a DI/RO humidifier because the fill valve is not an electric solenoid type; a mechanical fill valve maintains the proper water level. This fill valve operates independently of the Vapor-logic3 controller. Therefore, on a DI/RO system, Vapor-logic3 cannot keep track of the amount of water converted to steam between fill cycles.

Over-temperature fault (previous name: Thermal Trip Flt)

The Vapor-logic3 controller constantly monitors the tank temperature. If the temperature rises above the over-temperature set point (235 °F [113 °C]), the humidifier shuts down and a thermal trip fault is logged on the Alarms screen. The humidifier will not resume operation until you clear this fault.

Fault messages, continued

Sensor faults

The following is a list of sensor faults that can occur. The text in parentheses is the text that actually appears in the alarm log. Please note that this is a complete list of faults. Your system may not have all of these options.

- **Humidity transmitter fault (RH Trans Fault)**
The humidity sensor is incorrectly wired or defective.
- **Dew point transmitter fault (DP Trans Fault)**
The dew point sensor is incorrectly wired or defective.
- **VAV humidity transmitter fault (VAV Trans Flt)**
The duct humidity sensor is incorrectly wired or defective.
- **Temperature compensation transmitter fault (Temp Trans Flt)**
The temperature compensation sensor is incorrectly wired or defective.

Water level control faults

Below is a list of water level control faults that can occur. The text in parentheses is the text that appears in the alarm log.

- **Fill fault (Fill Fault)**
The fill valve has been energized for more than 40 minutes without the water reaching the top probe.
- **Drain fault (Drain Fault)**
The drain valve has been energized for more than 20 minutes without the water falling off the bottom probe.
- **Tank level fault (Tank Level Flt) (previous name: Fill Time Flt)**
The unit has run too long without the fill valve opening. Fill valve may be stuck open, heating devices may be damaged, or heater control may be faulty.
- **Low level probe fault (LL Probe Fault)**
The sensor has indicated that the water in the tank reached the middle or top probe without reaching the lower probe.
- **Mid level probe fault (ML Probe Fault)**
The sensor has indicated that the water in the tank reached the top probe without reaching the middle probe.
- **Probe assembly fault (Probe Assy Fault)**
The signal from the probes has deteriorated severely. Clean the probes and tank; however, the probes may need replacing.

Fault messages, continued

Humidifier faults

Below is a complete list of humidifier faults that can occur. (Your system may not have all these options.) The text in parentheses is the text that appears in the alarm log.

- **Temperature sensor fault (Tank Temp Fault)**
The temperature sensor on the humidifier tank is incorrectly wired or defective.
- **Thermal trip fault (Thermal Trip)**
The tank temperature has exceeded 235 °F (113 °C).
- **Boil time fault (Boil Time Flt)**
The water in the tank failed to boil within the maximum boil time.
- **SDU fault (SDU Fault)**
The SDU blower pressure switch failed to close when the SDU started.
- **Flue fault (Flue Fault)**
The air damper limit switch and/or the power vent pressure switch failed to close after the combustion air blowers started.
- **Burner [No.] fault (Burner [No.] Fault)**
The burner failed to light after nine ignition attempts.
- **Ignitor [No.] fault (Ignitor [No.] Fault)**
The ignition control module failed to energize the gas valve on every ignition attempt.
- **Blower [No.] fault (Blower [No.] Fault)**
The specified blower was unable to reach the desired speed.
- **Gas Valve [No.] fault (Gas Valve [No.] Fault)**
The indicated gas valve is open and should not be.

Main menu: System Set Up screen

System Set Up

Use the System Set Up screen to set the operational parameters of the humidifier. To modify a value, use the Next and Back soft keys to locate the parameter you want to change. Once the parameter is located, use the vertical arrow keys (or + and – keys) to change values; use the left and right arrow keys to move to a different digit on the parameter being modified. The modification takes effect when you press Enter or move to another parameter using the Next or Back soft key or exit the Set Up menu using the Main soft key.

For more information on each Set Up menu parameter, see the table below, which continues on the next page.

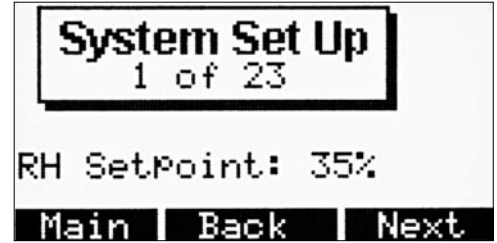

**Table 53-1:
Set Up menu information**

Set Up menu parameter	Set Up menu description	Range	Default
RH Setpoint	Relative humidity set point	20% RH to 80% RH	35%
RH Offset	RH offset calibration	±20% RH	0%
Dewpoint Setpoint	Dew point set point	20 °F to 80 °F (–7 °C to 27 °C)	50 °F (10 °C)
Dewpoint Offset	Dew point offset calibration	±20 °F (±20 °C)	0 °F (–18 °C)
PID Band	PID loop modulation band	1% RH to 20% RH	10%
Kp	Proportional gain factor	1 to 1000	80
Ki	Integral gain factor	0 to 1000	40
Kd	Derivative gain factor	0 to 1000	0
Duct High Lim RH	Duct high limit RH set point	50% RH to 95% RH	80%
Duct RH Offset	Duct RH offset calibration	±20% RH	0%
Temp Comp Offset	Temp comp sensor calibration	±20 °F (±20 °C)	0 °F (–18 °C)
ADS Mode (automatic drain sequence)	Autodrain operating mode	Use Use + Interval Interval	Use
Lbs of H2O Until ADS (Kg of H2O Until ADS)	Lbs (kg) of water that must be boiled for ADS to start	1 lb to 32,767 lbs (0.5 to 14,863 kg)	System dependent

Notes:

- Your system may not have all of these parameters.
- More parameters on the next page.

Main menu: Set Up screen, continued

**Table 54-1:
Set Up menu information**

Set Up menu parameter	Set Up menu description	Range	Default
ADS Day	Day to start ADS sequence	Sunday (1) through Saturday (7)	1
ADS Hour	Hour to start ADS sequence	0 to 23 (midnight to 11:00 pm)	0
ADS Interval	Number of days between ADS cycles	1 day to 180 days	1 day
ADS Duration	Auto drain sequence duration	0 minutes to 120 minutes	System dependent: STS 14 mins. GTS 18 mins. Vaporstream 12 mins. Vapormist, CRUV, Humidi-tech 8 mins.
AFS Duration	Auto flush sequence duration	0 minutes to 15 minutes	1 minute
Service Setpoint	Service interval set point	100 lbs to 3,276,700 lbs (100 kg to 1,486,300 kg)	System dependent
Water til Service	Amount of water remaining until service interval is met	Enter key resets service interval	NA
Skim Duration	Skim time duration	0 seconds to 120 seconds	System dependent: STS 35 seconds GTS 40 seconds Vaporstream 30 seconds Vapormist, CRUV, Humidi-tech 9 seconds
Heater Cycle Time (TP-type control)	Cycle time	30 seconds to 99 seconds	60 seconds
Heater Cycle Time (SSR-type control)	Cycle time	1 second to 30 seconds	2 seconds
SDU Area-type Duration	How long the fan runs after there is no call for humidity	5 minutes to 30 minutes	5 minutes
Aquastat	Aquastat set point	40 °F to 180 °F (4 °C to 82 °C)	40 °F (4 °C)
Inactivity Until EOS	Inactivity time until end-of-season drain cycle starts	1 hour to 168 hours	72 hours
Set Up Password	Password required to enter the Set Up screen	0 to 255 (0 = password disabled)	0
Configuration String	See configuration string section in this manual	System dependent	System dependent
Date: Time:	Date and time settings	NA	Current date/time
Idle Time	Keypad inactivity duration until the idle screen appears	Off to 1000 minutes	5 minutes
Note: • Your system may not have all of these readouts.			

Adjusting set point

Adjusting set point through the Set Up menu

You can adjust your unit's set point using the Set Up menu, which is under the Main menu (see the menu structure diagram on Page 44).

Once you access the Set Up menu, you can adjust a number of parameters including the set point of the unit. To adjust the humidity set point, your unit must be configured for a humidity transmitter. You can enter a desired humidity set point anywhere in the range of 20% to 80%. Your set point modifications take effect as soon as you press Enter, or move to another parameter using the Next or Back soft keys, or exit the Set Up menu using the Main soft key.

Depending on your options, you also can adjust the high limit humidity set point and the dew point set point. The high limit set point has a valid range of 50% to 95%. The dew point set point has a valid range of 20 °F to 80 °F (-7 °C to 27 °C).

PID tuning

Adjusting set point with PID loop

When your unit is equipped with a humidity or dew point transmitter, you can adjust and control the set point through the keypad/display, using a proportional, integral, and derivative (PID) control loop.

With a PID loop, you can “tune” your system for maximum performance using the proportional (Kp), integral (Ki), and derivative (Kd) gain terms. These gain factors work in the following way: the overall demand in a PID system is made up of three distinct parts added together—the proportional, the integral, and the derivative. Each of these parts is calculated and then multiplied by its corresponding gain factor. These gain factors are the setup variables you have access to from the Set Up menu. By making a gain factor larger, you increase its overall influence on system demand. Once each PID component is multiplied by its gain factor, all three terms are added together to determine the overall demand percentage.

The proportional term

The proportional term is the difference between the RH set point and the actual humidity multiplied by the proportional gain. For example, with a Kp of 80 and the actual humidity 5% below the RH set point, the proportional contribution to the demand is: $5 \times 80 \times 0.085 = 34\%$ (the 0.085 is an internal scalar used to increase the usable span of Kp).

There is a problem with using only proportional gain to control the RH. In almost all applications there is some constant load on the humidifier just as there is a constant load on heating equipment. If the proportional term is all that is used, the actual humidity must be less than the set point for the humidifier to be on.

What happens is the humidifier finds a “happy medium” where the actual humidity is something less than the set point, which allows the humidifier to continue to run. This difference between the set point and the actual running humidity level is called the “droop.” This droop can be corrected using the next term, the integral gain.

PID tuning, continued

The integral term

The integral term is an accumulation of RH error over time multiplied by the integral gain. The way this works is as follows: every $\frac{1}{2}$ second when the demand is updated, the instantaneous RH error (RH set point – actual RH) is added to a temporary variable that accumulates the error. This accumulated error is multiplied by the integral gain to create the integral term. The integral gain affects how fast the humidifier corrects a droop condition. The higher the integral gain (K_i), the faster the reaction. (An integral gain of zero disables this variable and allows the unit to run on the proportional term only.)

With an integral gain term greater than zero and an actual humidity below set point, the demand increases slightly with each update. If the actual humidity is above set point, the demand decreases slightly. The amount it increases or decreases depends on the magnitude of the RH error and the integral gain value. The closer you are to the set point, the smaller the addition or subtraction.

When looking at this control scheme, an interesting pattern occurs. The total demand signal for the humidifier is the sum of the proportional part, the integral part, and the derivative part. As the actual humidity approaches the set point, the integral portion makes up the majority of the demand, and the proportional part makes up very little. Once the set point is reached and the unit stabilizes, the entire demand is made up of the integral part because the proportional part is zero.

If the actual humidity goes over the set point, the integral term starts to decrease. In addition, the proportional term becomes negative and actually starts to subtract from the total system demand. These two terms work in conjunction with each other to bring the humidifier back to set point.

PID tuning, continued

The derivative term

The derivative term is the measured change in error over time multiplied by the derivative gain (differentiating error with respect to time). Its basic operation is as follows: if the actual measured RH is below set point and is rising, the derivative term subtracts from the demand in anticipation of the approaching set point.

If the actual measured RH is below set point and is falling, the derivative term adds to the demand in anticipation of the need to get the demand up faster and start climbing toward set point. If the actual measured RH is above set point and falling, the derivative term adds to the overall demand in anticipation of the approaching set point. It generally is used to increase damping and, in some cases, improves the stability of the system.

However, in the majority of control situations, the derivative term is not needed and is simply set to zero. The proportional term and integral term provide tight, accurate control without the addition of the derivative term.

PID band

The last user-controlled term in the PID equation is the PID band. The PID band defines the range of measured RH values (°F/°C for dew point control) where the PID loop is in operation. The PID loop is in operation when the measured RH is in the range of (RH set point – PID band) to (RH set point + PID band). If the measured RH is below the PID band, the PID calculations are suspended and the demand is set to 100%. Conversely, if the measured RH is above the PID band, the demand is set to 0%.

For example, if starting with an RH set point of 35% and a PID band of 10%, the PID loop operates when the actual humidity is in the range of 25% to 45%. If the actual humidity is lower than 25%, the humidifier is full on. If the actual humidity is above 45%, the humidifier demand is 0%. The PID band aids in speeding the response time of the system. It allows the RH to get somewhat close to the set point and then lets the PID loop precisely control the RH when it is within the PID band. The default value for the PID band is 10%.

Large spaces where the humidification system influences the RH very slowly typically benefit from a smaller PID band. Small spaces where the humidification system can quickly influence the RH typically benefit from a larger PID band. Rarely should it be set to less than 10%.

PID tuning, continued

PID setup tips

A large PID band (10% to 20%) yields tighter and more stable control with longer response times. A small PID band produces quicker response times, but control may become unstable if the RH regularly goes outside the band.

As a rule, start with a PID band of 10%. When the humidifier is operating at steady state, make sure the RH does not go outside the PID band. The intent of the PID band is to quickly get the RH into a controllable range. To increase or decrease the effect of the proportional term on system performance, adjust the proportional gain (K_p).

However, for the majority of systems, the factory default setting of 80 is sufficient. Generally speaking, a large integral gain (K_i) quickens the system response but may cause it to oscillate and become unstable. A small integral gain yields tighter, more stable control at the expense of a long response time.

These principles can be applied in the following examples: if a system eventually reaches the desired RH level but takes a long time to do so without overshooting the set point, faster response can be achieved by increasing the integral gain. If the measured RH oscillates above and below the set point numerous times before finally reaching set point, decrease the integral gain.

Typically speaking, if a large adjustment is made to the integral gain, better response is achieved by decreasing the magnitude of the change. Then modify the proportional gain slightly in the same direction the integral gain was changed. The RH graph on the reports menu, which displays the effect modifying PID gain values has on system response, can aid in PID loop tuning. The RH graph feature is explained in the reports section on Page 69.

K_p = Proportional gain factor

K_i = Integral gain factor

K_d = Derivative gain factor

VAV, temp comp control operation

VAV control

With VAV control, the system is equipped with a duct RH transmitter. This transmitter monitors the RH in the duct downstream from the steam dispersion unit and transmits the duct RH to the Vapor-logic3 controller. The controller then compares the measured duct RH with the high limit set point (Duct High Lim RH), which is entered through the keypad/display in the Set Up screen. If the measured duct RH comes within 6% of the duct high limit set point, the system output is proportionally throttled back.

If the duct RH reaches the duct high limit set point, the humidifier is completely disabled. When any reduction in system output occurs due to the VAV control, the “VAV Output Limit” message appears on the Idle screen. When the measured duct RH is more than 6% below the duct high limit set point, normal system operation is restored automatically, and the “VAV Output Limit” message disappears from the Idle screen.

Temperature compensation control

With temperature compensation (temp comp) control, the system is equipped with a window temperature transmitter. This transmitter monitors interior double-pane window glass temperature and transmits this temperature to the Vapor-logic3 controller.

The controller assumes a 70 °F (21 °C) room temperature and uses the glass temperature and the RH in the space being controlled to calculate the dew point temperature for the space.

As the window glass temperature decreases and approaches the dew point of the room, the RH set point decreases automatically to prevent moisture from forming on the windows. The modified RH set point appears on the Idle screen. An asterisk (*) appears next to the modified RH set point, denoting that temp comp has taken control of the RH set point, and the “*Temp Comp” message appears on the Idle screen.

Once the window temperature rises, the original RH set point is restored. The temperature compensation option is available only when the system is equipped with an RH transmitter. It is not available when a remote humidistat or building automation system is used to control the humidifier.

Dew point control, tank preheat operation

Dew point control

Dew point control functions in exactly the same way as RH control except the dew point is being measured instead of the RH. The dew point transmitter sends a signal to the Vapor-logic3 controller. Users can modify the dew point set point and PID parameters through the keypad/display just as they can with an RH transmitter.

Tank preheat feature

The tank preheat feature heats the water in the tank to near boiling to allow a rapid response to a demand signal. Its operation is as follows: If the tank is cold when a small demand signal is present, the Vapor-logic3 controller overrides the demand signal and runs the humidifier at 100% demand until the tank temperature reaches 190 °F (88 °C).

At this point, control is returned to the original demand signal and the humidifier begins normal operation. This allows the system to respond quickly to even the smallest demand. When preheating, the “Preheating Tank” message appears on the Idle screen. This feature is standard on all DRISTEEM humidifiers with Vapor-logic3 control except Steam Injection humidifiers.

Aquastat, freeze protection operation

Aquastat operation

The aquastat set point is the minimum tank temperature the Vapor-logic3 controller should maintain when there is no call for humidity. It is adjusted through the Set Up screen. This feature shortens the tank preheat time, which provides an even quicker response to a call for humidity.

For example, if the aquastat is set at 180 °F (82 °C) when a call for humidity occurs, the tank only needs to warm up 32 °F (18 °C) to reach the boiling point and start producing steam. However, if the aquastat is at its minimum default setting of 40 °F (4 °C) and the tank is in an average-temperature occupied room, the tank will be about 70 °F (21 °C). In this situation, when a call for humidity occurs, the tank needs to warm up 142 °F (79 °C) to reach the boiling point and begin producing steam. When an aquastat call is heating the tank, the “Aquastat Heating” message appears on the Idle screen.

This feature is standard on all DRISTEEM humidifiers with Vapor-logic3 control except Steam Injection humidifiers.

Freeze protection

Freeze protection is similar to the aquastat with several notable exceptions. The freeze protect set point is fixed at 40 °F (4 °C). Its sole purpose is to prevent the tank from freezing in cold environments. Unlike aquastat, if a condition exists that prevents the heaters, burners, and valves from firing (such as an alarm, an external interlock switch is open, or the humidifier is in Standby mode), instead of remaining idle, the tank drains to prevent freezing.

When the tank is heating or draining to prevent freezing, the “Freeze Protection” message appears on the Idle screen.

This feature is standard on all DRISTEEM humidifiers with Vapor-logic3 control except Steam Injection humidifiers.

SDU/fan operation, sensor offsets

SDU operation

If your humidifier is equipped with a Space Distribution Unit (SDU) or an Area-type fan, it is enabled after the Vapor-logic3 receives a call for humidity and the tank temperature rises above 150 °F (66 °C).

When the humidifier no longer receives a call for humidity, it stops heating and the SDU or Area-type fan continues to run for the SDU Duration to ensure that steam gets dispersed. The SDU Duration is adjustable in one-minute intervals (default is 5 minutes) through the Set Up screen.

Sensor offsets

All external transmitters shipped with Vapor-logic3 can be field calibrated using the keypad/display through the Set Up screen. For example, if the system is equipped with an RH transmitter, there is an RH offset setting.

The factory default for all transmitter offset settings is zero. If an adjustment is necessary, use the keypad to adjust the transmitter reading up or down through this setting. The sensors that have this adjustment capability are the humidity, VAV high limit, temp comp, and dew point transmitters.

Automatic drain sequence (ADS)

**Table 64-1:
System-dependent defaults for
automatic drain sequence (ADS)**

Humidifier	ADS duration (drain time in minutes)	AFS duration (flush time in minutes)
Vapormist	8	1
Humidi-tech	8	1
CRUV	8	1
Vaporstream	12	1
STS	14	1
LTS	14	1
GTS	18	1

Automatic drain sequence for potable water (not softened)

When configured to run a potable water humidifier with an automatic drain valve, Vapor-logic3 uses an automatic drain sequence (ADS) to help reduce mineral accumulation in the tank and drain line to decrease tank maintenance.

The ADS sequence starts by opening the drain valve to empty the tank. The default drain time (ADS duration) is product specific for potable water (see Table 64-1). Once the drain time expires, the fill and drain valves remain open to flush the tank. The default flush time (AFS duration) is one minute. Once the flush timer expires, the ADS is complete and the humidifier resumes normal operation.

Automatic draining and flushing can be adjusted using the Set Up screen on the keypad/display. The user can set the drain and flush duration, and can also set when the draining and flushing occurs. There are three options (modes) for defining when draining and flushing occurs:

1. After a user-defined amount of water has been converted to steam (“Use” mode)
2. At a defined time (“Interval” mode)
3. After a user-defined amount of water has been converted to steam and at a defined time “Use + Interval” mode)

These three modes are defined in more detail below. Please note that these options are available only with a standard water system with an automatic drain valve. If the humidifier is configured for DI/RO water or if the unit has a manual drain valve, these drain and flush options are not available.

ADS modes

1. Use

Draining and flushing based on usage is the default ADS mode. When the ADS mode is set to “Use,” the humidifier enters a drain and flush sequence after a user-defined amount of water has converted to steam. For example, if the “Lbs of H2O until ADS” setup parameter is set to 10,000 lbs (4536 kg/h) in the Set Up menu, the humidifier enters a drain and flush sequence the moment 10,000 lbs (4536 kg/h) of water convert to steam. This allows the unit to drain and flush the moment it is needed.

Automatic drain sequence (ADS), continued

2. Interval

When the ADS mode is set to “Interval,” the humidifier enters a drain and flush sequence after a user-defined interval of time, ignoring the amount of water converted to steam. The interval is established by setting the “ADS day,” “ADS hour,” and “ADS interval” parameters in the Set Up menu (the “Lbs of H₂O until ADS” parameter is not used when the ADS mode is set to Interval). Once the ADS day is reached, the drain and flush occurs at the ADS hour. The unit drains and flushes again after the number of days specified by the ADS interval has passed.

For example, if the user sets the ADS day to Sunday, ADS hour to 13, and the ADS interval to seven days, the humidifier enters the drain and flush sequence every Sunday at 1:00 p.m. In this example, if the ADS interval is changed from seven to six days, the first ADS occurs on Sunday, the next on Saturday, the next on Friday, and so on.

Note that if the ADS interval is not a multiple of seven days, the ADS day becomes meaningless after the first drain and flush sequence until the ADS mode is reset. The Interval ADS mode allows the user to keep the humidifier on-line until a convenient time for the drain and flush sequence.

3. Use + Interval

When the ADS mode is set to “Use + Interval,” the humidifier enters the drain and flush sequence after both the Use and Interval requirements are met, as stated in sections 1 and 2 above. For example, if the user sets the “Lbs of H₂O until ADS” to 10,000 lbs (4536 kg/h), the ADS day to Sunday, ADS hour to 23, and the ADS interval to one day, every day at 11:00 p.m. the humidifier will check to see if at least 10,000 lbs (4536 kg/h) of water converted to steam since the last ADS. If so, the humidifier drains and flushes. If not, the humidifier waits until the next interval (in this example, one day) to see if the usage requirement is met. This allows the unit to drain and flush at a convenient time.

Automatic drain sequence (ADS), end-of-season draining (EOS)

Draining when using softened water

When using softened water and when the program code indicates either “S” or “T” for the “Type of water level control” being used (see the configuration string nomenclature on Pages 32 and 33), then draining occurs for a one-minute duration every 28 days to remove residue from the drain valve mechanism. End-of-season draining occurs as described below.

Skim timer

With a potable or softened water configuration, the Vapor-logic3 controller is equipped with a skim timer. This timer is activated at the end of each fill cycle. The timer keeps the fill valve open (for a user-determined amount of time after the tank has filled) to skim minerals off the water surface. The skim time is adjusted through the Set Up screen.

End-of-season drain

If there is no call for humidity for a preset time period, the humidifier is placed in End of Season (EOS) mode. When the unit enters EOS mode, the drain valve remains open for ten hours to allow the tank to drain and then closes. When the humidifier receives a call for humidity after the end-of-season drain, the tank refills and the humidifier resumes normal operation.

The amount of inactivity time needed before the humidifier enters End Of Season is adjustable through the Set Up screen on the keypad/display (Inactivity Until EOS). This option is available only on units equipped with automatic drain and fill valves.

Service interval, setting date and time

Service interval

The Vapor-logic3 controller tracks the amount of water converted to steam by the humidifier. When the amount of water converted to steam exceeds the Service set point (a user-defined amount of water in pounds or kilograms adjusted in the system Set Up screen), the “Service Humidifier” message appears on the Idle screen.

The humidifier continues to operate after the message appears. The message notifies the user that the service interval was reached and the humidifier should be cleaned. To remove the “Service Humidifier” message from the Idle screen and reset the Service Interval, press Enter when viewing the “Water til Service” parameter in the Set Up menu.

Setting date and time

The Vapor-logic3 controller contains a real-time clock that is used for several features including the drain and flush sequence and the logging of alarms. If you need to reset the date or time, both are accessible through the Set Up screen.

Main menu: Diagnostics screen

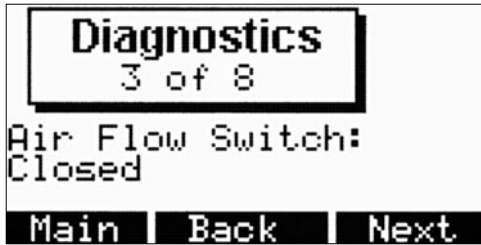

Diagnostics

The Diagnostics screen allows you to monitor all of the analog and discrete inputs to the Vapor-logic3 control system. Use the Next and Back to scroll through the input signals on your system.

The Diagnostics screen is useful when troubleshooting. For example, to troubleshoot the RH signal input, select RH Signal on the Diagnostics screen. The screen displays the input signal in milliamps and what this signal translates to in terms of relative humidity. You then can verify that the input is working correctly.

The table below lists available Diagnostic menu items (depending on system options and type) with normal values and/or ranges.

**Table 68-1:
Diagnostics menu items**

Display item		Normal values and/or ranges			
RH input	X	4 mA to 20 mA	0% to 100%	% RH	
Demand input	Configuration string	E	4 mA to 20 mA	0% to 100%	
		H	0 VDC to 10 VDC	0% to 100%	
		D	6 VDC to 9 VDC	0% to 100%	
		N	Open or closed	0% or 100%	
		C	0 to 150 ohms	0% to 100%	
		L	Demand input not displayed.		
		Dew point input		4 mA to 20 mA	0 °F to 100 °F
Duct HL input		Open or closed			
Temp comp input		4 mA to 20 mA	-20 °F to 160 °F	-28 °C to 71 °C	
High probe voltage		2.3 VAC No water	0.0 VAC Water		
Mid probe voltage		2.3 VAC No water	0.0 VAC Water		
Low probe voltage		2.3 VAC No water	0.0 VAC Water		
DI float		2.3 VAC No water	0.0 VAC Water		
Tank temp input		0 to 2120 ohms	-240 °F to 265 °F	-151 °C to 129 °C	
Airflow switch		Open or closed			
Safety interlock		Open or closed			
GTS only	Model	100	300	200, 400, 600, 800	
	Blower 1 rpm	0 to 2800 rpm	0 to 3700 rpm	0 to 5200 rpm	
	Blower 2 rpm	0 to 2800 rpm	0 to 3700 rpm	0 to 5200 rpm	
	Blower 3 rpm	0 to 2800 rpm	0 to 3700 rpm	0 to 5200 rpm	
	Blower 4 rpm	0 to 2800 rpm	0 to 3700 rpm	0 to 5200 rpm	
	Burner 1 gas valve	Open or closed			
	Burner 2 gas valve	Open or closed			
	Burner 3 gas valve	Open or closed			
	Burner 4 gas valve	Open or closed			
	Combustion air switch	Open or closed			
	Power vent switch	Open or closed			

Main menu: Reports screen

Reports

The Reports menu displays up to four report options to help the user gain historical data on the humidification system. Information contained in each report is explained below.

Water usage report

The Water Used report displays how many pounds (kilograms) have been converted to steam in the humidifier. For Vapor-logic3 versions 3.0.1 and higher, reset this total from the water usage report screen by pressing the Reset soft key. The date the water usage was reset last also appears on the report. For Vapor-logic3 versions previous to 3.0.1, the water usage report is reset when the service interval is reset from the Set Up menu.

Energy usage report

The Energy Used report displays how much energy was consumed by the humidifier. Depending on the system type, this number may be in kWh, MBtu, therms, etc. For Vapor-logic3 versions 3.0.1 and higher, reset this total from the energy usage report screen by pressing the Reset soft key. The date the energy usage was last reset also appears on the report. For Vapor-logic3 versions previous to 3.0.1, the energy usage report is reset when the service interval is reset from the Set Up menu.

RH/dew point history report

The RH (or dew point — depending on system configuration) history report provides a way to track minimum and maximum RH or dew point. To allow trending over a desired interval of time, reset this data at any time by pressing the Reset soft key. The date the RH or dew point history was reset last also appears on the report. Use the Back soft key to return to the Reports menu. Use the Main soft key to return to the Main Menu. The history report is disabled on systems with an external control signal by others.

Main menu: Reports screen, continued

Figure 70-1:
Oscillating RH demand graph

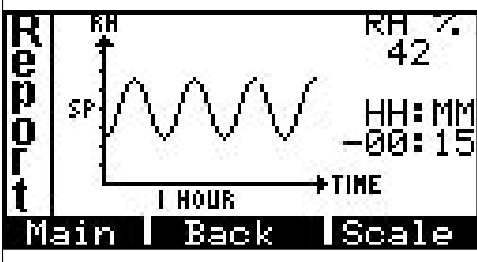

Figure 70-2:
RH demand graph, set point not reached

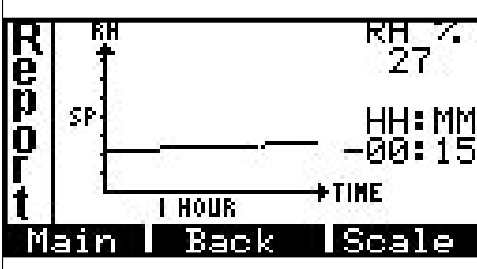
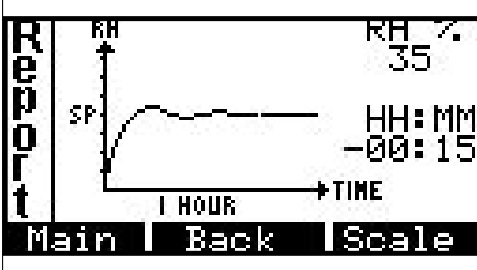

Figure 70-3:
RH demand graph, operating properly



RH/dew point/demand graph

The RH (or dew point or demand) graph provides a graphical depiction of RH change over time. Examples of this are shown in Figures 70: 1–3.

The vertical axis either displays RH in 1% increments, dew point in 1 degree increments, or demand in 2.5% increments depending on system configuration. On the RH graph, the RH set point is denoted by SP in the middle of the vertical axis.

Data is graphed over three different time intervals: the last 10 minutes, the last 1 hour, or the last 24 hours. Scroll through each interval by pressing the Scale soft key.

Use the Back soft key to return to the Reports menu. Use the Main soft key to return to the Main menu. The left and right arrows move the blinking cursor across each data point on the curve. The value of the blinking cursor's data point appears in the upper right corner of the screen. The time (how long ago) when that data point was taken appears directly below its value.

The graph is useful when tuning the PID loop (adjusting the proportional, integral, and derivative gain values). Consider the following examples: Figure 70-1 depicts a system where the RH is oscillating and may not maintain the RH set point. This is an example where K_i (integral gain) is too high. Figure 70-2 depicts a system where the RH either takes too long to reach set point or never reaches set point. This system would benefit from increased K_i . Figure 70-3 depicts a perfectly tuned system.

Start-up checklist

Your humidification system may not have all of the options listed below. If an item does not apply to your system, skip to the next item and continue the process.

- Before you start, read this manual and other information sent with your humidifier.
- Verify that the field wiring is done per the instructions in this manual and per the unit wiring diagram.
- If your humidifier uses potable or softened water (non-DI water), check probe voltages in the Diagnostics menu. The reading should be 2.3 VAC without water and 0 VAC with water from ground (terminal 33 on J8) to probe inputs (terminals 30, 31, and 32 on J8).
- Check the heater cycle time setting (except for GTS) in the “System Set Up” menu of the keypad/display (default is 60 seconds; 2 seconds for SSR).
- If your system uses an RH transmitter, check the proportional band setting in the System Set Up menu of the keypad/display (default is 10%).
- If your system uses an RH transmitter, check the proportional gain (Kp) setting in the System Set Up menu of the keypad/display (default is 80).
- If your system uses an RH transmitter, check the integral gain (Ki) setting in the System Set Up menu of the keypad/display (default is 40).
- If your system uses an RH transmitter, check the derivative gain (Kd) setting in the System Set Up menu of the keypad/display (default is 0).
- If your system has an electronic drain valve, check the drain duration (system dependent; see the table on Page 64).

More on next page ►

Start-up checklist, continued

Start-up checklist (continued)

- Check the flush duration (default is 1 minute).
- Check the RH set point and set at the desired level.
- Confirm that the control input signal is consistent with the Vapor-logic3 configuration string. Identify the factory-set Vapor-logic3 configuration string on the wiring diagram or on the outside of the control cabinet door. Refer to the configuration string descriptions on Pages 32 and 33.
- Confirm that all wiring is correct per the wiring diagram.
- Confirm that proper grounding and an approved earth ground are provided.
- Confirm that the analog inputs are configured properly by verifying that J14/J17, J15/J18, and J16/J19 shunt connectors on the Vapor-logic3 board are in their correct position per the wiring diagram. See Pages 11 and 13 for the physical locations.
- Confirm that the keypad/display is mounted with modular cable routed away from high voltage circuits and connected to the J2 female connector on the Vapor-logic3 board.
- Turn water supply on and confirm that the drain valve is closed.
- Turn power on and confirm that the display shows the Main Menu screen with an operational clock.
- Enter the Control Modes screen and make sure the system is in auto mode.
- When “Filling” appears on the status line of the Idle screen, confirm that the tank is filling with water.
- Confirm that the airflow switch is closed.

More on next page ►

Start-up checklist, continued

Start-up checklist (continued)

- ❑ Confirm that the high limit humidistat input is closed or that the variable air volume (VAV) control system high limit transmitter is connected.

IMPORTANT: Confirm that the tank has sufficient water.

If the tank does not contain water and the heat outputs are activated, or the burners are fired by the Vapor-logic3 control system, a serious failure will result. If this happens, immediately remove power from the system and verify that all wiring is done per the wiring instructions in this manual and the unit wiring diagram.

- ❑ With sufficient water in the tank, the airflow switch closed, the high limit humidistat closed, the safety interlock circuit closed, and a call for humidity, verify that the heat outputs are activated.
- ❑ Check amp draw of heaters for electric units; refer to wiring diagram for proper rating. If unit is powered by steam, check for steam flow. For gas fired units, verify gas flow and combustion.
- ❑ During normal operation, the humidifier operating status appears in the keypad/display. See Pages 46 and 47 for descriptions of keypad/display status items.
- ❑ If you experience difficulties, have the above keypad/display information available with the model and serial numbers of the humidifier and the Vapor-logic3 configuration string and call DRISTEEM for assistance.

Troubleshooting introduction

1. Review troubleshooting index.

If you have a control-related problem, first check the problem list in this section. If you have a tank-related or dispersion-related problem, you may also need to refer to those specific product manuals.

2. Review possible causes and recommended actions.

The troubleshooting guide on the following pages presents possible causes and recommended actions for typical problems.

3. If you're still having problems, call us.

If the troubleshooting guide does not help you solve your problem, call us with the following information available:

- Product name, configuration string code, and serial number
You'll find this information on the wiring diagram and on the outside of the control cabinet door.
- Problem definition
Example: water leaking, low humidity, high humidity, etc.
- Time problem began
Example: Always, after remodel, after a change in weather, etc.
- System changes
Example: Pressure, new boiler, new service, new controller, relocation, change in maintenance, etc.

Calling DRISTEEM technical support

Have the following information ready before calling technical support.

Humidifier model number _____

Humidifier serial number _____

Current Vapor-logic3 configuration string _____

Problem definition _____

Time problem began _____

Recent system changes _____

Index to troubleshooting guide

Below is an index to possible control-related problems described on the following pages. To find solutions, refer to the page number.

Description	Page	Description	Page
General		Operational problems	
Green power indicator light is off	76	Control does not energize	82
No remote fault indication	76	Unit does not fill with water	83
No readable information on keypad/display	76	Fill valve does not close	84
Faults		Reduced or no output	85
Humidity transmitter fault	76	Fill valve cycles on and off frequently	85
Dew point transmitter fault	76	Heater burnout	86
VAV humidity transmitter fault	76	Noisy operation	86
Temp comp transmitter fault	76	Display completely black	86
Fill fault	77	Humidity below desired level	87
Drain fault	78	Humidity above set point	88
Tank level fault	78	Hunting (RH swings above and below set point)	88
Fill time fault	78	Tank does not heat up	89
Boil time fault	78	Unit does not perform autodrain sequence	89
LL probe fault	79	Unit does not perform end-of-season drain	90
ML probe fault	79	Tank has proper water level and is always warm	90
Clean probes and tank message	80		
Probe assembly fault	81		
Tank temperature sensor fault	81		
Thermal trip fault	81		
SDU fault	81		
Checksum failure	81		
Flue fault	81		
Gas valve [no.] fault	82		
Burner [no.] fault	82		
Ignitor [no.] fault	82		
Blower [no.] fault	82		

Troubleshooting guide

**Table 76-1:
Vapor-logic3 troubleshooting guide**

Problem	Possible cause	Action
Green power indicator light is off	• No control voltage	• Check for proper supply voltage
	• Heater fuses open	• Check heater fuses for voltage present at transformer
	• Transformer secondary circuit breaker tripped	• Check for wiring shorts; reset breaker
No remote fault indication	• Field wiring not installed	• Provide field wiring to a remote fault indicator from Vapor-logic3 terminal block J22 (see Pages 11 and 14).
	• Field-supplied remote fault indicator lamp is burned out.	• Check if lamp by others is burned out; replace if needed.
	• Remote fault Vapor-logic3 relay is not switching.	• Check relay continuity (Vapor-logic3 terminal J22) for contact closure (see Page 11).
No readable information on keypad/display	• No power or incorrect voltage to Vapor-logic3 board	• Check main power supply • Reset control transformer circuit breaker if tripped. • Reset thermal cutout if tripped.
	• Modular communication cable is disconnected.	• Connect modular cable.
Transmitter faults/humidistat faults <ul style="list-style-type: none"> • Humidity transmitter fault (RH Trans Fault) • Dew point transmitter fault (DP Trans Fault) • VAV humidity transmitter fault (VAV Trans Flt) • Temp comp transmitter fault (Temp Trans Flt) 	<ul style="list-style-type: none"> • Open, shorted, or incorrect wiring of transmitter humidistat • Signal is incorrect, out of range, or miswired. • Ground loop • Control signal exceeded the range limits. Correct control signals are 4 to 20 mA, 0 to 135 ohms, or 0 to 15 VDC 	<ul style="list-style-type: none"> • Check DC supply voltage terminals: <ul style="list-style-type: none"> – RH transmitter: terminal 21: 21 VDC, terminal 23: GND – Dew point transmitter: terminal 21: 21 VDC, terminal 23: GND – VAV humidity transmitter: terminal 24: 21 VDC, terminal 26: GND – Temp. comp. transmitter: terminal 27: 21 VDC, terminal 29: GND – Humidistat: terminal 22: 21 VDC, terminal 23: GND • If there is no output 4 to 20 mA, replace transmitter. Transmitter by others may not be compatible. Consult DRISTEEM. • Isolation control board by others may not be compatible. Consult DRISTEEM. • Recalibrate if there is a calibration error: Normal range 4 to 20 mA = 0 to 100% RH; 12 mA = 50% RH • Measure for normal 1 to 5 VDC range on control RH transmitter or 4 to 20 mA by others: terminal 22+, terminal 23–.
		More on next page ►

Troubleshooting guide

**Table 77-1:
Vapor-logic3 troubleshooting guide**

Problem	Possible cause	Action
<p>Fill fault</p> <p>In fill sequence, Vapor-logic3 allows 40 minutes for the water to reach the maximum upper water level. If the water does not reach the designated level, and the probe system is not satisfied, a fault is indicated.</p> <p>Two main possibilities:</p> <ul style="list-style-type: none"> • Water is not there (tank is not full) • Water is not being detected (tank is full) 	Tank is not full	
	• Fill and drain valve wiring are reversed.	• Correct wiring.
	• Low water supply pressure	• Verify water pressure is 25 psi [552 kPa] minimum.
	• In-line strainer plugged	• Clean as needed.
	• Humidifier cover interlock switch improperly wired.	• Correct wiring.
	• Fill valve not open.	• If 24 VAC is present across fill valve coil, replace valve.
	• Fill valve not wired properly to control board	• Verify proper fill valve wiring at terminals 1 and 2. • Initiate a Vapor-logic3 test cycle.
	• Inlet water needle valve closed or plugged	• Check if needle valve is open and free of sediment.
	• Fill valve with incorrect operating voltage	• Verify valve coil is 24 VAC.
	• Plugged fill valve	• Remove fill valve and check for foreign material plugging the valve.
	• Fill valve plumbed backward	• Note flow direction and correct as needed.
	• Excessive water hammer can bend a needle valve and make it difficult to open.	• Replace valve, if needed. • Install a water hammer shock arrester.
	• Orifice after fill valve may be plugged.	• Service valve strainer and orifice assembly.
	• Drain valve leaking water	• Verify drain is in "Auto" position and is closed.
	Tank is full	
	• Probe is malfunctioning.	• Clean or replace probe.
	• Water conductivity is low. Standard water units require water conductivity to be 100 µS/cm minimum.	• Add salt to increase water conductivity. Consult DRISTEEM for further advice.
	• No tank ground.	• Install tank ground.

More on next page ►

Troubleshooting guide

**Table 78-1:
Vapor-logic3 troubleshooting guide**

Problem	Possible cause	Action
<p>Drain fault</p> <p>When in autodrain sequence or end-of-season drain, Vapor-logic3 allows 20 minutes for the water level to drop from the top probe to below the lowest probe (for standard water units) or to the low-water switch level (DI water units with end-of-season drain). If the tank does not drain to this level in the time allotted, a fault is indicated.</p>	<ul style="list-style-type: none"> • Tank drain outlet 	<ul style="list-style-type: none"> • If the humidifier tank drain outlet is plugged, clean.
	<ul style="list-style-type: none"> • Water detection probes 	<ul style="list-style-type: none"> • Clean probe or replace probe rod assembly.
	<ul style="list-style-type: none"> • Drain valve wiring 	<ul style="list-style-type: none"> • Check drain valve wiring. • Check to be sure drain valve is wired to terminals 3 and 4 on control board. • Reset Vapor-logic3.
	<ul style="list-style-type: none"> • Fill valve 	<ul style="list-style-type: none"> • Check for voltage present at the valve. If present, clean or replace valve. • Replace fill valve if water is leaking through.
	<ul style="list-style-type: none"> • System programmed for manual drain 	<ul style="list-style-type: none"> • Run a test cycle to see if the system activates drain output.
	<ul style="list-style-type: none"> • Drain line backing up with water • Drain line plugged 	<ul style="list-style-type: none"> • Insufficient drain line pitch • Insufficient drain line size; 1¼" (DN32) is minimum diameter for drain line lengths over 10' (3 m)
<p>Tank level fault (Tank Level Flt) (previous name: Fill Time Flt)</p>	<ul style="list-style-type: none"> • Fill valve is stuck open 	<ul style="list-style-type: none"> • Check valve for foreign matter.
	<ul style="list-style-type: none"> • Fill valve is installed backward. 	<ul style="list-style-type: none"> • Check arrow direction on valve; or "In" should be visible on fill valve body.
	<ul style="list-style-type: none"> • Excessive condensate is draining into the tank. 	<ul style="list-style-type: none"> • Consult DRISTEEM to increase the amount of water that can be converted to steam before receiving a fault.
<p>Boil time fault</p>	<ul style="list-style-type: none"> • Faulty tank temperature sensor 	<ul style="list-style-type: none"> • Verify tank temperature sensor is functioning correctly and is affixed to the tank; 70 °F (27 °C) measures 1000 ohms.
	<ul style="list-style-type: none"> • Diminished output 	<ul style="list-style-type: none"> • See "Reduced or no output" entry in this troubleshooting guide.
	<ul style="list-style-type: none"> • Tank is not insulated 	<ul style="list-style-type: none"> • Temperature must reach 190 °F (88 °C) in 60 minutes. Insulate tank.
More on next page ►		

Troubleshooting guide

**Table 79-1:
Vapor-logics troubleshooting guide**

Problem	Possible cause	Action
<p>Low level probe fault (LL probe fault)</p> <p>The lowest probe showed no water when one of the upper probes did show water.</p>	<ul style="list-style-type: none"> • Low conductivity water supply 	<ul style="list-style-type: none"> • If conductivity is less than 100 $\mu\text{S}/\text{cm}$ add salt to increase conductivity. Consult DRISTEEM for further advice. • Measure 0 VAC from probes to ground when water is in contact with probes.
	<ul style="list-style-type: none"> • Dirty or oxidized probes 	<ul style="list-style-type: none"> • Clean probe, removing oxidation and/or minerals or replace if needed.
<p>Mid level probe fault (ML probe fault)</p> <p>The middle probe showed no water when the upper probe did show water.</p>	<ul style="list-style-type: none"> • Incorrect installation 	<ul style="list-style-type: none"> • Verify proper wiring of probe system. Shielded (screened) wiring is not recommended. • Verify probe wiring is not routed with high voltage wiring. • Verify wiring between control cabinet and humidifier does not exceed the recommended 50' (15 m) limit. • Verify fill and drain plumbing was installed per the instructions in the humidifier's manual. • Verify piping from the humidifier to the dispersion assembly is installed correctly, that there are no elbows or restrictions in the piping, and that the length of the piping is not too long. See instructions in the humidifier's manual. • Verify there is a P-trap installed on the tank and/or that the P-trap is not plugged. • Verify maintenance; clean if needed.
<p>More on next page ►</p>		

Troubleshooting guide

**Table 80-1:
Vapor-logic3 troubleshooting guide**

Problem	Possible cause	Action
"Clean probes and tank" message appears on idle screen	<ul style="list-style-type: none"> Low water conductivity 	<ul style="list-style-type: none"> Check conductivity. Water conductivity must be at least 100 $\mu\text{S}/\text{cm}$. If conductivity is low, add salt to increase conductivity. Consult DRISTEEM for further advice.
	<ul style="list-style-type: none"> System detected a need to clean or replace probe. 	<ul style="list-style-type: none"> Remove and clean probe rods. Drain tank water to below the probe; reset system and restart.
	<ul style="list-style-type: none"> Mineral buildup or oxidation on probe rod 	<ul style="list-style-type: none"> Clean probe rods.
	<ul style="list-style-type: none"> Incorrect wiring of probe 	<ul style="list-style-type: none"> Check for proper wiring. Do not use shielded cable. Probe wires must be routed separately from high voltage wires to avoid interference.
	<ul style="list-style-type: none"> Deterioration of probe rod assembly 	<ul style="list-style-type: none"> Replace probe rod assembly.
	<ul style="list-style-type: none"> Probe signal too low 	<ul style="list-style-type: none"> Measure probe voltages. With water off the probe, voltage should be 2.2 VAC or greater from each probe to ground. When probe is touching water, voltage should measure 0 VAC.
	<ul style="list-style-type: none"> Probe wiring 	<ul style="list-style-type: none"> Check for proper wiring. Machine ground must be present between control cabinet and humidifier tank. Do not use shield (screen) cable. Individual 18-gauge (1 mm²) standard wire is recommended. Maximum wiring distance is 50' (15 m) from humidifier to control cabinet.
	<ul style="list-style-type: none"> Reset to clear message 	<ul style="list-style-type: none"> Drain humidifier tank completely; reset Vapor-logic3 to restart system.
	<ul style="list-style-type: none"> Poor continuity 	<ul style="list-style-type: none"> Verify that there is a machine ground between control cabinet and humidifier tank.

More on next page ►

Troubleshooting guide

**Table 81-1:
Vapor-logic3 troubleshooting guide**

Problem	Possible cause	Action
Probe assembly fault (Probe Assy Ft)	<ul style="list-style-type: none"> Deterioration of probe rod assembly 	<ul style="list-style-type: none"> Replace probe rod assembly.
	<ul style="list-style-type: none"> Humidifier interlock switches and/or over-temperature thermostat 	<ul style="list-style-type: none"> Verify that switch or thermostat is wired. Verify interlock switch is set correctly and humidifier cover is on. Reset over-temperature thermostat if tripped.
Tank temperature fault	<ul style="list-style-type: none"> Open, shorted, or incorrect wiring of sensor 	<ul style="list-style-type: none"> Check wiring terminals (terminal J25) for correct wiring and voltages (see Page 14). 1000 ohms = 72 °F (22 °C); 1695 ohms = 212 °F (100 °C)
	<ul style="list-style-type: none"> Humidifier interlock switches and/or over-temperature thermostat 	<ul style="list-style-type: none"> Verify that switch or thermostat is wired. Verify interlock switch is set correctly and humidifier cover is on. Reset over-temperature thermostat if tripped.
Thermal trip fault	<ul style="list-style-type: none"> Unit has overheated; temperature over 235 °F (113 °C) 	<ul style="list-style-type: none"> Check for proper water level in tank.
	<ul style="list-style-type: none"> Faulty sensor 	<ul style="list-style-type: none"> Repair sensor or replace.
SDU fault	<ul style="list-style-type: none"> SDU blower or airflow proving switch is incorrectly wired. 	<ul style="list-style-type: none"> Check SDU for proper wiring.
	<ul style="list-style-type: none"> SDU blower cover is off. 	<ul style="list-style-type: none"> Install cover.
	<ul style="list-style-type: none"> SDU blower motor is defective (SDU fan does not start) 	<ul style="list-style-type: none"> Replace SDU blower.
	<ul style="list-style-type: none"> Breaker tripped 	<ul style="list-style-type: none"> Reset breaker.
Checksum failure	<ul style="list-style-type: none"> Internal program changed (Vapor-logic3 detected a change from its previous program check) 	<ul style="list-style-type: none"> Consult DRISTEEM for reprogramming instructions.
Flue fault	<ul style="list-style-type: none"> The combustion air damper is incorrectly wired or failed to open 	<ul style="list-style-type: none"> Check for proper combustion air damper wiring.
	<ul style="list-style-type: none"> The power vent pressure switch is incorrectly wired, or the power vent failed to start. 	<ul style="list-style-type: none"> Check for proper power vent wiring.

More on next page ►

Troubleshooting guide

**Table 82-1:
Vapor-logic3 troubleshooting guide**

Problem	Possible cause	Action
Gas valve [no.] fault	<ul style="list-style-type: none"> • Failed ignition module • Miswired gas valve 	<ul style="list-style-type: none"> • Check ignition module. • Check gas valve wiring.
Burner [no.] fault	<ul style="list-style-type: none"> • No gas supply to unit 	<ul style="list-style-type: none"> • Verify that gas service valve is on and receiving minimum pressure to manifold per rating plate.
	<ul style="list-style-type: none"> • Gas valve is off or there is no power to the valve. 	<ul style="list-style-type: none"> • Verify that valve is in the "on" position and that there is power to the valve.
	<ul style="list-style-type: none"> • Broken ignitor 	<ul style="list-style-type: none"> • Verify that ignitor glows.
	<ul style="list-style-type: none"> • Gas valve/ignitor/sensing electrode is out of sequence. 	<ul style="list-style-type: none"> • Verify wire connections to these components.
	<ul style="list-style-type: none"> • Gas valve outlet pressure is too low. 	<ul style="list-style-type: none"> • Verify outlet pressure is set per rating plate.
	<ul style="list-style-type: none"> • Blower inlet is dirty or obstructed. 	<ul style="list-style-type: none"> • Clean inlet and check for obstructions.
Ignitor [no.] fault	<ul style="list-style-type: none"> • Defective ignition control module 	<ul style="list-style-type: none"> • Verify ignition sequence.
	<ul style="list-style-type: none"> • Gas valve/ignitor/sensing electrode is out of sequence. 	<ul style="list-style-type: none"> • Verify wire connections to these components.
Blower [no.] fault	<ul style="list-style-type: none"> • The blower is incorrectly wired, or the blower failed to start. • Expansion board failed. 	<ul style="list-style-type: none"> • Check for proper blower wiring. • Replace blower. • Replace expansion board.
Control does not energize.	<ul style="list-style-type: none"> • Nonexistent supply voltage to unit 	<ul style="list-style-type: none"> • Check main fuse. • Check main line safety switches. • Check heater fuses.
	<ul style="list-style-type: none"> • Nonexistent control voltage 	<ul style="list-style-type: none"> • Check for proper supply. • Verify proper transformer voltage characteristics. • Verify proper wiring of transformer. • Check for control circuit voltage, 24 VAC. If voltage is not present, check transformer circuit breaker. Reset if needed.
	<ul style="list-style-type: none"> • Humidifier over-temperature thermostat open 	<ul style="list-style-type: none"> • Reset manual switch located above heater below humidifier cover.

More on next page ►

Troubleshooting guide

**Table 83-1:
Vapor-logic3 troubleshooting guide**

Problem	Possible cause	Action
Unit does not fill with water.	<ul style="list-style-type: none"> Malfunctioning fill valve 	<ul style="list-style-type: none"> Unplug probe head. Fill valve should open. If fill valve does not open, verify proper 24 VAC (terminals 1 and 2) to fill valve. If voltage is present and valve does not open, replace valve or valve coil. Verify that coil is 24 VAC. Verify that valve stem moves freely.
	<ul style="list-style-type: none"> No water supply to fill valve 	<ul style="list-style-type: none"> Check if water supply line strainer is plugged. Verify that manual water line shut-off valve is open and that pressure exists. Check that in-line needle valve is open.
	<ul style="list-style-type: none"> Unit is not in Auto Mode. 	<ul style="list-style-type: none"> Go to Control Modes screen and select Auto.
	<ul style="list-style-type: none"> Vapor-logic3 control is in end-of-season drain mode. 	<ul style="list-style-type: none"> Check for humidification demand signal at control board terminals 21, 22, and 23 of terminal block J26 (see Pages 11 and 14).
	<ul style="list-style-type: none"> Malfunctioning level control system 	<ul style="list-style-type: none"> Check terminals 30, 31, 32, and 33 on Vapor-logic3 control board terminal block J8 for correct voltage: <ul style="list-style-type: none"> 32 to 33, no water present > 2 VAC 32 to 33, water present < 2.5 VAC 31 to 33, same readings as above 30 to 33, same readings as above
	<ul style="list-style-type: none"> Inlet water needle valve is closed. 	<ul style="list-style-type: none"> Check needle valve.
	<ul style="list-style-type: none"> Unit is in "Freeze Protection Draining" 	<ul style="list-style-type: none"> Reset power.
	<ul style="list-style-type: none"> Fill valve stuck in closed position. 	<ul style="list-style-type: none"> Recycle power to recycle fill valve closing and opening.
More on next page ►		

Troubleshooting guide

**Table 84-1:
Vapor-logic3 troubleshooting guide**

Problem	Possible cause	Action
Fill valve does not close.	<ul style="list-style-type: none"> • Open drain valve 	<ul style="list-style-type: none"> • If automatic drain valve is locked in the manual open position, reset to automatic. • Replace valve if there is a broken return spring on the drain valve. • Clean or replace drain valve if an obstruction in the valve does not allow complete closure. • Close manual drain valve if it is open. • If Vapor-logic3 shorted output to fill valve coil, replace board or drain coil.
	<ul style="list-style-type: none"> • Malfunctioning level control system 	<ul style="list-style-type: none"> • Check that probe head is plugged in fully. • If needed, clean probe rods. • Verify whether Vapor-logic3 control board with nylon mounting standoffs terminal 33 needs to be grounded. • If water conductivity is less than 100 $\mu\text{S}/\text{cm}$, add salt to tank water. If this solves the problem, you have low-conductivity water; consult DRISTEEM for further advice. • Replace board if Vapor-logic3 control board is defective. • Verify that system is in auto mode. • Verify that probe is wired correctly. • Check terminals 30, 31, 32, and 33 on Vapor-logic3 control board terminal block J8 for correct voltage: <ul style="list-style-type: none"> – 32 to 33, no water present > 2 VAC – 32 to 33, water present < 0.25 VAC – 31 to 33, same readings as above – 30 to 33, same readings as above
	<ul style="list-style-type: none"> • Fill valve is stuck. 	<ul style="list-style-type: none"> • Check if fill valve is installed backwards. If yes, repipe. • If there is a faulty internal spring or diaphragm in the fill valve, replace valve. • Check if there is an obstruction that does not allow valve to seat properly. Clean or replace valve as needed. • Check for control voltage across fill valve coil. (Check wiring and controls.) • Install water inlet shock arrestor.

More on next page ►

Troubleshooting guide

**Table 85-1:
Vapor-logic3 troubleshooting guide**

Problem	Possible cause	Action
Reduced or no output (even though water level is correct).	Electric units: • Heater malfunctioning	<ul style="list-style-type: none"> • Verify that proper voltage is being applied to heaters. • Verify heater amperage matches wiring diagram. • If heater contactor is not functioning, replace.
	Electric units: • Malfunctioning control system	<ul style="list-style-type: none"> • Check if heater fuses are blown and replace if required. • Check if auxiliary limit controls are not allowing system to operate, e.g., duct humidistats, airflow proving switch, etc. Reset, replace or calibrate as needed. (Airflow switch, terminals 12 and 13, measures 24 VAC if open. On-off high limit, terminals 25 and 26, measures 21 VDC if open. • Check if the heater over-temperature thermostat has tripped. Reset if necessary.
	GTS, STS or LTS units: • Dirty heat exchanger	<ul style="list-style-type: none"> • Clean
	GTS units: • Dirty burners • Low gas pressure	<ul style="list-style-type: none"> • Clean or adjust as appropriate.
Fill valve cycles on and off frequently (several times per minute)	• Malfunctioning level control system	<ul style="list-style-type: none"> • If needed, clean probes. • Check water conductivity. Minimum conductivity for proper operation of level control system is 100 μS/cm. • Verify that probe wiring is correct.
	• Drain valve not fully closed	<ul style="list-style-type: none"> • If an obstruction does not allow drain valve to fully close, clean valve. • If there is a broken or weak return spring on drain valve, replace the valve. • Check if 24 VAC is present at valve. If so, check wiring of Vapor-logic3 control board terminals 3 and 4.
	• Poor tank ground	<ul style="list-style-type: none"> • Verify good machine ground.
More on next page ►		

Troubleshooting guide

**Table 86-1:
Vapor-logic3 troubleshooting guide**

Problem	Possible cause	Action
Heater burnout	<ul style="list-style-type: none"> Water level is too low. 	<ul style="list-style-type: none"> Replace probes.
	<ul style="list-style-type: none"> Improper wiring 	<ul style="list-style-type: none"> Verify proper voltage applied to heater. Verify proper electrical connections.
	<ul style="list-style-type: none"> Mineral buildup on heaters 	<ul style="list-style-type: none"> The humidifier may be undersized. Increase humidifier capacity or replace with larger humidifier. Consult DRISTEEM. Inspect tank for severe mineral buildup on or around heater. Increase skim duration, frequency of drain cycle, and/or frequency of cleaning. Use softened makeup water.
	<ul style="list-style-type: none"> Contactors failed to close. 	<ul style="list-style-type: none"> Replace.
	<ul style="list-style-type: none"> SSR or SCR failed closed 	<ul style="list-style-type: none"> Replace SSR or SCR controller.
	<ul style="list-style-type: none"> Heater corrosion 	<ul style="list-style-type: none"> Inspect heater for surface corrosion or pitting. Before replacing burned-out heater verify chloride content in supply water is very low.
Noisy operation	<ul style="list-style-type: none"> Thunder-type noise coming from tank during refill 	<ul style="list-style-type: none"> Normal on larger units. Caused by the cold fill water collapsing steam in the tank. Reduce incoming water pressure (minimum 25 psi [172 kPa]; minimum 60 psi [414 kPa] for STS-DI 800) if inlet water pressure is too high, or adjust the needle valve.
	<ul style="list-style-type: none"> Contactor noise 	<ul style="list-style-type: none"> Contactor normally makes a “clunk” sound as it pulls in. A continuous chattering noise is not normal and is symptomatic of a failing contactor or malfunctioning controls. Replace contactor or troubleshoot the control system.
	<ul style="list-style-type: none"> Fill valve noise 	<ul style="list-style-type: none"> A clicking sound as the fill valve opens or closes, and a hissing sound during fill are normal. A slamming sound as the fill valve closes is “water hammer” and can be minimized by installed a shock arrester. A loud buzzing sound indicates poor alignment of the valve stem. Replace valve.
Display is completely black.	<ul style="list-style-type: none"> Keypad is overheated. 	<ul style="list-style-type: none"> Cool the keypad.
	<ul style="list-style-type: none"> Communication cable not connected 	<ul style="list-style-type: none"> Connect cable.
	<ul style="list-style-type: none"> Defective cable 	<ul style="list-style-type: none"> Replace cable.
	<ul style="list-style-type: none"> Defective keypad 	<ul style="list-style-type: none"> Replace.
	<ul style="list-style-type: none"> Defective control board 	<ul style="list-style-type: none"> Depress button on board near service indicator. If indicator doesn't illuminate with a constant brightness, replace control board.

More on next page ►

Troubleshooting guide

**Table 87-1:
Vapor-logic3 troubleshooting guide**

Problem	Possible cause	Action
Humidity is below desired level.	<ul style="list-style-type: none"> Unit is operating but fails to meet required humidity level. 	<ul style="list-style-type: none"> Unit undersized; replace with a larger unit or add additional humidifier. Skim duration is too long. If drain valve does not close fully, determine the cause and clean, repair, or replace as needed. If drain pipe water seal is allowing steam to go down the drain, repair as needed. If there is an improper water seal height, increase to the recommended height (see humidifier tank manual for water seal height). If there is excessive internal steam pressure, determine the cause of the high pressure (e.g., high duct static pressure, undersized orifices in dispersion tubes, water, or crushed vapor hose) and correct as required. Replace leaking gasket or vapor hose. Recalibrate if controls are out of calibration. If fill valve is stuck open, repair or replace. If zone valve will not open, repair or replace.
	<ul style="list-style-type: none"> No call for humidity from humidistat or from control and high limit humidity transmitters 	<ul style="list-style-type: none"> Low or no signal strength from humidistat. Check for proper wiring. Check humidity transmitters (4 to 20 mA output) Adjust set point if Vapor-logic3 set point is too low.
	<ul style="list-style-type: none"> Excessive outside air volume 	<ul style="list-style-type: none"> Verify proper operation of fans, dampers, VAV systems, etc.
	<ul style="list-style-type: none"> Heating elements not operating 	<ul style="list-style-type: none"> If heaters are burned out, refer to "Heater burnout" problem on Page 86. Verify that humidistat is calling for humidity. Check for control voltage if limit controls (airflow proving switch, zone valves, etc.) are not allowing unit to operate. Check fuses and replace if they are blown. Check if the heater over-temperature has been tripped. Reset if necessary.
	<ul style="list-style-type: none"> Humidity control input type not the same as Vapor-logic3 software 	<ul style="list-style-type: none"> Check Vapor-logic3 control board connections J26, J27, and J28 (see Pages 13 and 14). Consult DRISTEEM.
	<ul style="list-style-type: none"> Vapor-logic3 not in "Auto" 	<ul style="list-style-type: none"> Go to Control mode; select and enter "Auto."

More on next page ►

Troubleshooting guide

**Table 88-1:
Vapor-logic3 troubleshooting guide**

Problem	Possible cause	Action
Humidity above set point	• High entering relative humidity	• Dehumidify
	• Unit oversized	• Consult DRISTEEM.
	• Reduced airflow	• Check fans, dampers, VAV systems, etc.
	• Improperly located humidistat or humidity transmitters	• Relocate, using guidelines established in this manual (see Pages 25–31)
	• Malfunctioning controls	<ul style="list-style-type: none"> • Check for incorrect supply voltage. • Check for incorrect control signal. • Check for improper wiring hookup. • If humidity controller or transmitter are out of calibration or malfunctioning, repair or recalibrate. • Check if SSR/SCR contactor shorted. Repair or replace as needed.
Hunting (humidity swings above and below desired set point)	• Malfunctioning control system	<ul style="list-style-type: none"> • If there is a faulty or inaccurate humidity controller or transmitter, repair or replace. • Check for proper Vapor-logic3 control settings: RH set point, high limit set point, cycle rate, PID tuning, etc. • Relocate poorly located control components. See humidity control placement information on Page 25 for recommendations. • On SSR units: Control wire and power wires must be physically separated from each other. If they are not, an induced control voltage can occur, causing erratic operation. • Verify that 6-wire keypad/display modular cable is isolated from power wiring.
	• Air volume varies rapidly	• Stabilize.
	• Air temperature is varying rapidly.	• Stabilize to ± 1 °F (± 1 °C)
	• Proportional band is too small and/or integral gain (Ki) is too large	<ul style="list-style-type: none"> • If RH swings outside PID band, increase PID band using the keypad Set Up menu. • Decrease integral gain (Ki) using the Set Up menu.
More on next page ►		

Troubleshooting guide

**Table 89-1:
Vapor-logic3 troubleshooting guide**

Problem	Possible cause	Action
Tank does not heat up	<ul style="list-style-type: none"> Over-temperature thermostat switch located under heater wiring cover tripped 	<ul style="list-style-type: none"> Reset thermostat switch.
	<ul style="list-style-type: none"> Humidifier cover interlock switch (Vaporstream models only) 	<ul style="list-style-type: none"> Humidifier cover not wired; adjust interlock switch.
	<ul style="list-style-type: none"> Combustion air switch or power vent switch (GTS only). 	<ul style="list-style-type: none"> Check venting system and combustion dampers. Verify wiring and connections on switches are properly connected.
	<ul style="list-style-type: none"> Incorrect or nonexistent control voltage 	<ul style="list-style-type: none"> Check for proper supply voltage on electrical diagram. Verify proper transformer voltage characteristics. Verify proper wiring of transformer. Check for control circuit voltage on electrical diagram. If voltage is not present, troubleshoot boards and wiring system for potential short circuit.
	<ul style="list-style-type: none"> Incorrect or nonexistent supply voltage to the unit 	<ul style="list-style-type: none"> Check main line fuse. Check main line safety switch. Check heater fuses and wiring diagram.
Unit does not perform autodrain sequence.	<ul style="list-style-type: none"> Humidifier may not have automatic drain system. 	<ul style="list-style-type: none"> Inspect unit to verify that an automatic drain valve was furnished. Check configuration string (see Pages 32–33).
	<ul style="list-style-type: none"> Drain fault, plugged drain valve, or plugged drain pipe 	<ul style="list-style-type: none"> Clean drain valve piping.
	<ul style="list-style-type: none"> Malfunctioning autodrain sequence. 	<ul style="list-style-type: none"> Check Vapor-logic3 ADS (automatic drain sequence) settings from the Set Up menu and reset if necessary.
	<ul style="list-style-type: none"> No power to the automatic drain valve 	<ul style="list-style-type: none"> Check if 24 VAC is present at Vapor-logic3 terminals 3 and 4 and at drain valve.
	<ul style="list-style-type: none"> Defective automatic drain valve 	<ul style="list-style-type: none"> If voltage is present at the valve and it still does not open, replace valve.
	<ul style="list-style-type: none"> Vapor-logic3 configuration: The unit may be set for manual drain. 	<ul style="list-style-type: none"> Initiate a test cycle to see if the drain valve cycles open and then closes. If not, system needs to be reprogrammed.

More on next page ►

Troubleshooting guide

**Table 90-1:
Vapor-logic3 troubleshooting guide**

Problem	Possible cause	Action
Unit does not perform end-of-season drain.	• Input signal always has a demand	• Reduce demand signal.
	• Vapor-logic3 program	• Verify configuration string is set for end-of-season drain.
	• Drain valve	• Valve not wired, or incorrectly wired, to control board. • Check 24 VAC across valve coil during test cycle.
Humidifier tank has proper water level and is always warm	• Aquastat	• This is normal; the aquastat is maintaining a certain tank water temperature within range of 40 °F to 180 °F (4 °C to 82 °C). • Readjust aquastat temperature to a lower set point.
	• SSR/SCR power controller	• SSR/SCR control devices shorted closed; check/replace. • Phase-to-phase wiring crossed.
	• Contactor	• Contactor shorted closed; check/replace.

Replacement parts

**Figure 91-1:
Vapor-logics replacement parts**

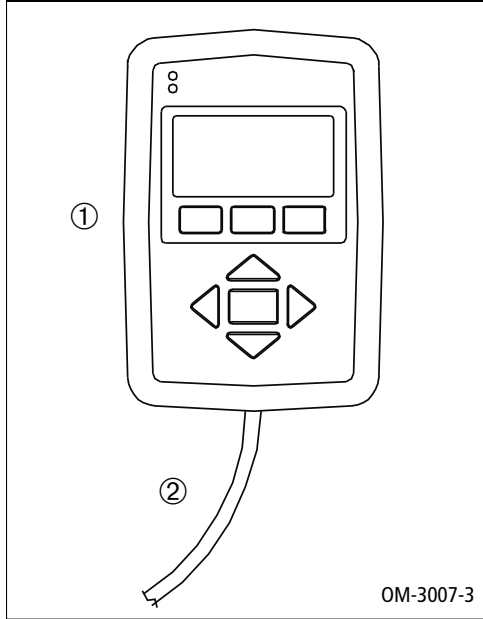

**Figure 91-2:
Vapor-logics replacement parts**

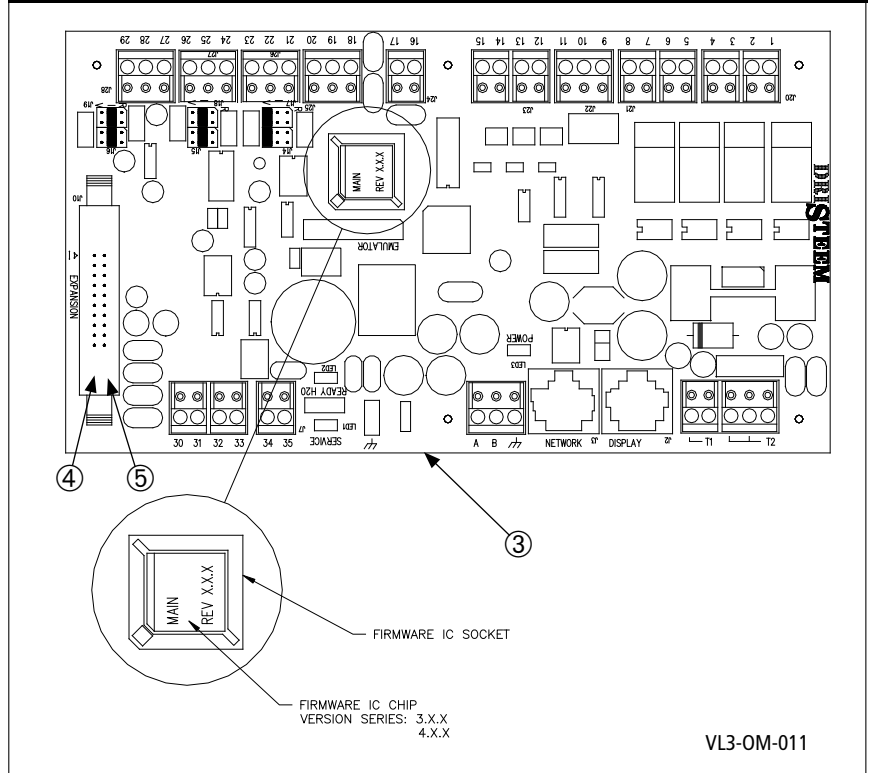

**Table 91-1:
Vapor-logics replacement parts**

No.	Description	Qty.	Part no. for Versions 2.x	Part no. for Versions 3.x	Part no. for Versions 4.x
1	Display board	1	408490-*	408491-002	408491-*
2	Cable	1	408490-**	408490-**	408490-**
3	Main board	1	408490-001	408491-*	408491-*
4	Expansion board (GTS)	1 or 2	408490-004	408490-004	408490-004
5	Expansion board (Vaporstream)	1	408490-003	408490-003	408490-003

Notes:

* See main board drawing above to identify firmware version for proper part replacement.

** Part number varies with cable length. Specify humidifier model and serial number when ordering.

Expect quality from the industry leader

For 40 years, DRISTEEM has been leading the industry with creative and reliable humidification solutions. Our focus on quality is evident in the construction of the Vapor-logic³ and an industry-leading two year warranty that covers all parts.

For more information

www.dristeem.com
sales@dristeem.com

Technical support

800-328-4447

DRISTEEM Corporation

An ISO 9001: 2000 certified corporation and a subsidiary of Research Products Corporation

U.S. Headquarters:

14949 Technology Drive
Eden Prairie, MN 55344
800-328-4447
952-949-2415
952-229-3200 (fax)

European office:

Bell Place, Bell Lane
Syresham, Brackley
NN13 5HP, UK
+44 1280 850122 (voice)
+44 1280 850124 (fax)
E-mail: 106277.1443@compuserve.com

Continuous product improvement is a policy of DRISTEEM Corporation; therefore, product features and specifications are subject to change without notice.

DRISTEEM, CRUV, Dri-calc, GTS, Humidi-tech, LTS, Rapid-sorb, STS, Ultra-sorb, Vapor-logic, Vapormist, and Vaporstream are registered trademarks of DRISTEEM Corporation and are filed for trademark registration in Canada and the European community. Area-type and Drane-kooler are trademarks of DRISTEEM Corporation.

Product and corporate names used in this document may be trademarks or registered trademarks. They are used for explanation only without intent to infringe.

© 2004 DRISTEEM Corporation



Form No. VL3-IOM-1204-global
Part No. 890000-709 Rev C

Two-year limited warranty

DRISTEEM Corporation (“DRISTEEM”) warrants to the original user that its products will be free from defects in materials and workmanship for a period of two (2) years after installation or twenty-seven (27) months from the date DRISTEEM ships such product, whichever date is the earlier.

If any DRISTEEM product is found to be defective in material or workmanship during the applicable warranty period, DRISTEEM’s entire liability, and the purchaser’s sole and exclusive remedy, shall be the repair or replacement of the defective product, or the refund of the purchase price, at DRISTEEM’s election. DRISTEEM shall not be liable for any costs or expenses, whether direct or indirect, associated with the installation, removal or reinstallation of any defective product.

DRISTEEM’s limited warranty shall not be effective or actionable unless there is compliance with all installation and operating instructions furnished by DRISTEEM, or if the products have been modified or altered without the written consent of DRISTEEM, or if such products have been subject to accident, misuse, mishandling, tampering, negligence or improper maintenance. Any warranty claim must be submitted to DRISTEEM in writing within the stated warranty period.

DRISTEEM’s limited warranty is made in lieu of, and DRISTEEM disclaims all other warranties, whether express or implied, including but not limited to any IMPLIED WARRANTY OF MERCHANTABILITY, ANY IMPLIED WARRANTY OF FITNESS FOR A PARTICULAR PURPOSE, any implied warranty arising out of a course of dealing or of performance, custom or usage of trade.

DRISTEEM SHALL NOT, UNDER ANY CIRCUMSTANCES BE LIABLE FOR ANY DIRECT, INDIRECT, INCIDENTAL, SPECIAL OR CONSEQUENTIAL DAMAGES (INCLUDING, BUT NOT LIMITED TO, LOSS OF PROFITS, REVENUE OR BUSINESS) OR DAMAGE OR INJURY TO PERSONS OR PROPERTY IN ANY WAY RELATED TO THE MANUFACTURE OR THE USE OF ITS PRODUCTS. The exclusion applies regardless of whether such damages are sought based on breach of warranty, breach of contract, negligence, strict liability in tort, or any other legal theory, even if DRISTEEM has notice of the possibility of such damages.

By purchasing DRISTEEM’s products, the purchaser agrees to the terms and conditions of this limited warranty.