

READ AND SAVE THESE INSTRUCTIONS

VAPORMIST® and VAPORMIST® DI ELECTRIC STEAM HUMIDIFIERS

Installation Instructions
and
Maintenance Operations
Manual

For Toll-Free Technical Support,
Call 1-800-328-4447



ETL LISTED



cETL LISTED

DRISTEEM®
HUMIDIFIER COMPANY



TABLE OF CONTENTS

TO THE PURCHASER AND INSTALLER

Thank you for purchasing our VAPORMIST® humidifier. We have designed and built this equipment to give you complete satisfaction and trouble-free service for many years. Familiarizing yourself with this manual will help ensure you proper operation of the equipment for years to come.

This manual covers the installation and maintenance procedures for both the VAPORMIST and VAPORMIST DI humidifiers.

DRI-STEEM Humidifier Company

VAPORMIST Humidifier	3
Installation	
Locating and Mounting the VAPORMIST Humidifier	4
Examples of Mounting the Dispersion Tube	4
Mounting Dispersion Tube with Condensate Drain Line	5
Connecting Dispersion Tube and Humidifier	5
Piping and Wiring	6
Electrical Specifications and Capacities/Dimensions	7
AREA-TYPE Application Using Space Distribution Units (SDU-E and SDU-I)	8
Start-up and Operation	10
Maintenance	11
VAPORMIST Trouble-Shooting Guide	13
VAPORMIST DI Trouble-Shooting Guide	14
Replacement Parts	15
Two-Year Limited Warranty	20

VAPORMIST® HUMIDIFIER

Figure 3-1: VAPORMIST Humidifier

The standard VAPORMIST unit requires water conductivity of at least 100 micromhos/centimeter (2 grains per gallon) to operate. It will not operate with water treated by reverse osmosis or deionization processes. (See DI model below.)

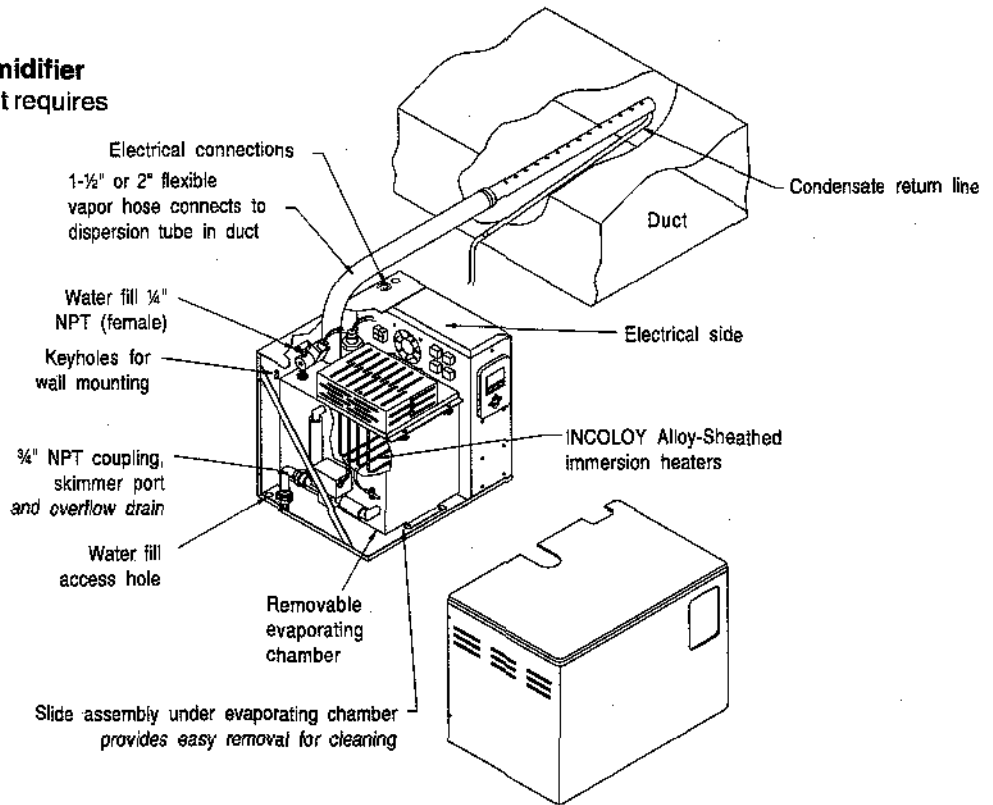

QM-82-4

Figure 3-2: VAPORMIST DI Humidifier (Deionized Water)

The VAPORMIST DI humidifier shown here is specifically designed for use with deionized or reverse osmosis water.

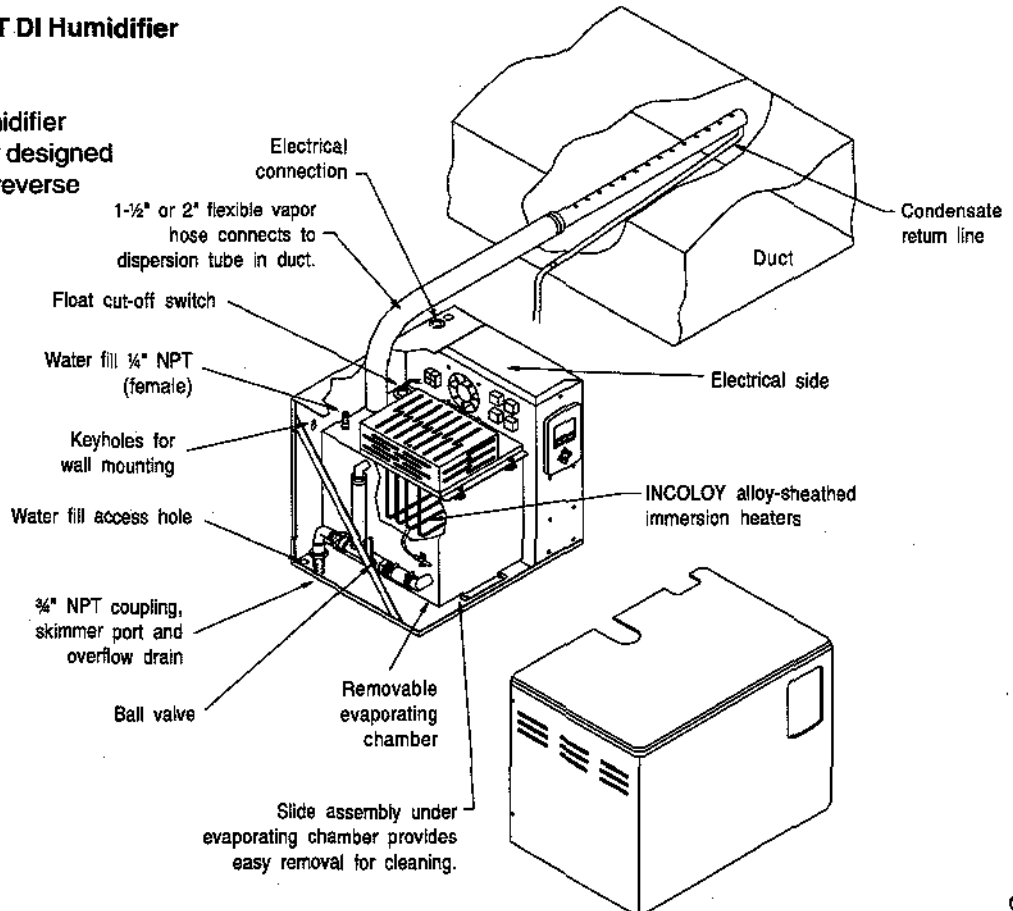

QM-82-5

INSTALLATION

Locating and Mounting the VAPORMIST® Humidifier

The VAPORMIST humidifier is designed to lag bolt to the wall, and it should be installed in a space located near an air duct system.

Consider the following when selecting the location of the humidifier:

- Convenient access to duct
- Electrical and plumbing connections
- Required clearances

The mounting location should provide a minimum clearance of 36" to the front and 24" to the right side of the unit. This clearance is required for removing the evaporating chamber and accessing the electrical compartment. Also, a minimum clearance of 6" to the left side is required for louvers and enclosure fasteners.

Examples of Mounting the Dispersion Tube

Figure 4-1: Mounted Horizontally in Duct

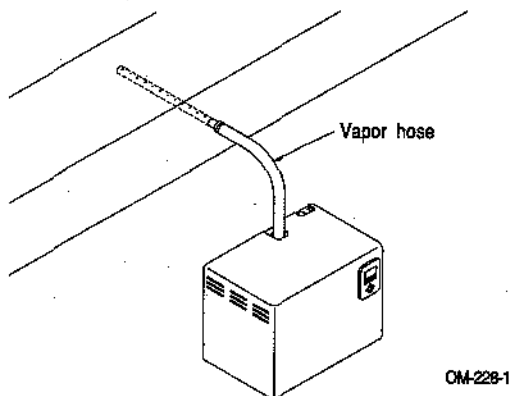

Vapor hose and dispersion tube should be pitched back to the humidifier with a gradual slope of 2" per foot (minimum). A single dispersion tube cannot be used with VM-30 or VM-34.

Figure 4-2: Mounted Horizontally in Duct and Lower than VAPORMIST Unit

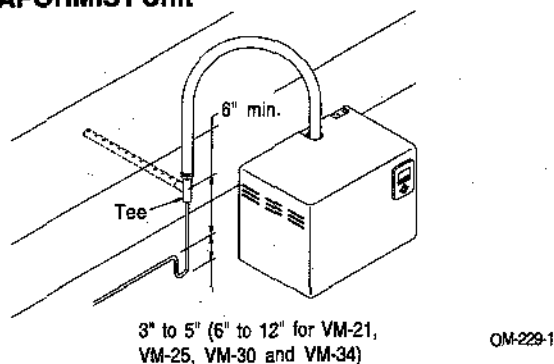

A water seal must be located in drain line as shown to maintain steam pressure. A single dispersion tube cannot be used with VM-30 or VM-34.

Electrical power supply, water make-up piping and drain piping must also be considered. Electrical power supply connections are made at the lower or upper right rear corner of the unit. Water makeup and draining piping connections are made at the lower left rear corner.

When mounting on a stud wall (studs 16" on center), locate studs and position lag bolts in place so that each of the two lags (16" apart) will center on a stud. Mark hole locations and pre-drill 1/4" diameter pilot holes using mounting template on VAPORMIST box. Secure frame to wall with lag bolts provided.

For hollow block or poured concrete wall mounting, position template in place and mark the holes. Drill appropriate pilot hole for two 3/8" toggle bolts or two 3/8" machine bolt lead anchors. Secure frame in place.

Figure 4-3: Mounted Vertically (Optional)

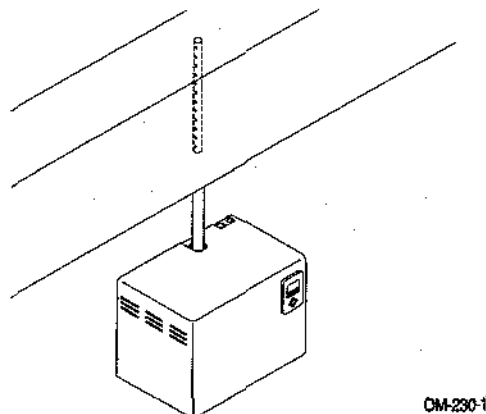

This is not recommended on models VM-10 through VM-34.

IMPORTANT NOTES: When duct is located more than 10 feet away from unit, vapor hose is not recommended; 1 1/2" minimum I.D. hard pipe should be used instead. VM-30 and VM-34 must use a multiple tube steam dispersion system.

Note: Following models require a minimum of:

VM2-10:	up to 30 lbs/hr	1 1/2" hose kit without drain
VM12-16:	up to 57 lbs/hr	1 1/2" hose kit with drain
VM12-16:	up to 57 lbs/hr	2" hose kit without drain
VM21-25:	up to 85 lbs/hr	2" hose kit with drain
VM30-35:	require multiple tube assemblies	

INSTALLATION

Figure 5-1: Single Tube

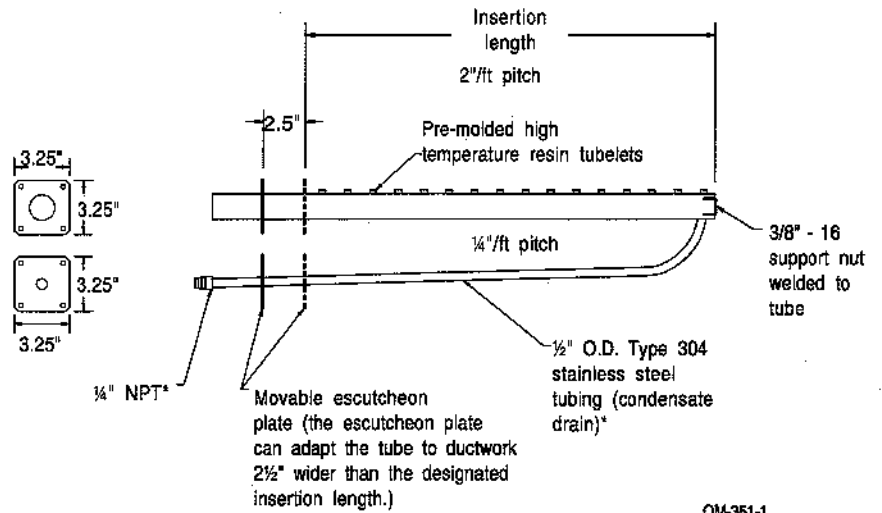

VAPORMIST® Mounting Tube with Condensate Drain Line

- Mount dispersion tube level.
- Orient dispersion tube so that tubelets are pointed straight up.

Connecting Dispersion Tube to Humidifier

- Connection can be made with vapor hose or hard piping.
- Hard piping should have a minimum I.D. of 1 1/2".
- A minimum pitch of 2" per foot back to the humidifier should be maintained.
- Short sweep 90° elbows are not recommended; use two 45° elbows 12" apart or long sweep 90° elbows instead.
- Thin-walled tubing will heat up faster than heavy-walled pipe, causing less steam loss at start-up.
- Insulating hard piping will reduce the steam output loss caused by condensation.
- When mounting the humidifier above the level of dispersion tube, see figure 4-2 on page 4.

Failing to follow these recommendations may result in excessive back pressures being imposed on the humidifier. This may lead to dispersion tube(s) spitting, steam blowing through water seals, or leaking gaskets. When the distance between humidifier and the dispersion tube(s) exceeds 20 feet, consult factory for recommendations.

Figure 5-2: RAPID-SORB® with Condensate Wasted to Floor Drain

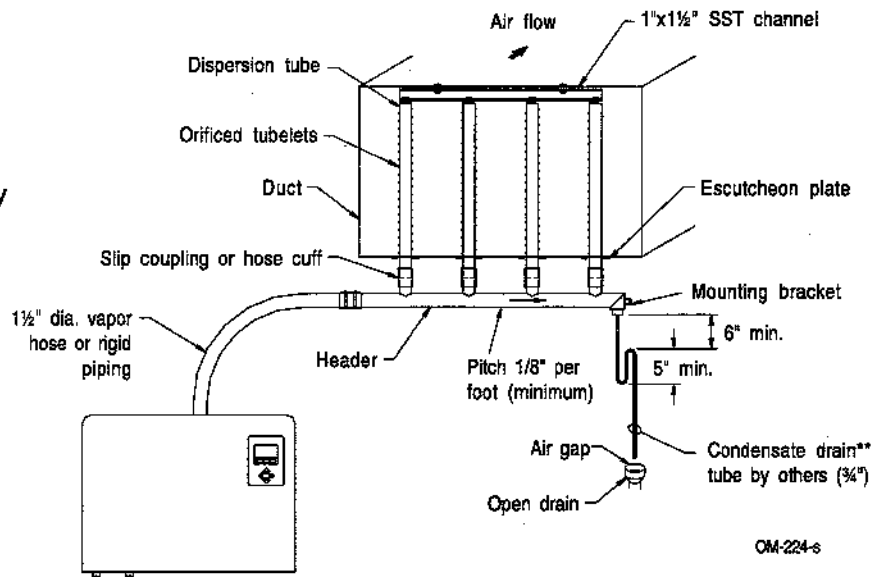

Notes:

- * 1/2" diameter condensate tubing is not needed nor provided when steam flow is 34 lbs per hour or less per dispersion tube. A minimum pitch of 2" per foot back to the humidifier should be maintained.
- ** Condensate drain tubing material must be suitable for 212°F (100°C) water.

PIPING AND WIRING

Water make-up piping may be of any code-approved material (copper, steel, or plastic). The final connection size is 1/4" NPT. In cases where water hammer may be a possibility, a shock arrestor should be considered.

Drain piping may be of any code-approved material (copper, steel, or plastic rated for 212°F minimum). If drainage by gravity is not possible, a small lift pump should be used. (DRI-STEEM part #400280.)

The final connection sizes are 3/4" NPT for drain fitting and frame drain. This connection size should not be reduced. (See figures 6-1 and 6-2 for proper drain piping configurations.) The evaporator drain should be piped and discharge into a floor drain. Combining the two drain pipes into a single drain line may result in the backflow of drain water into the humidifier cabinet, causing the unit to malfunction.

Figure 6-1: Drain Adjacent to Wall

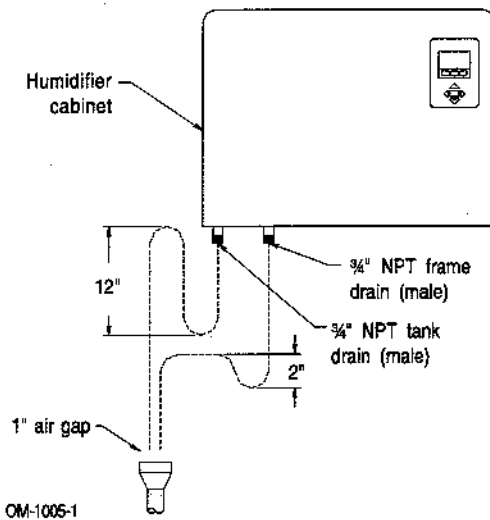
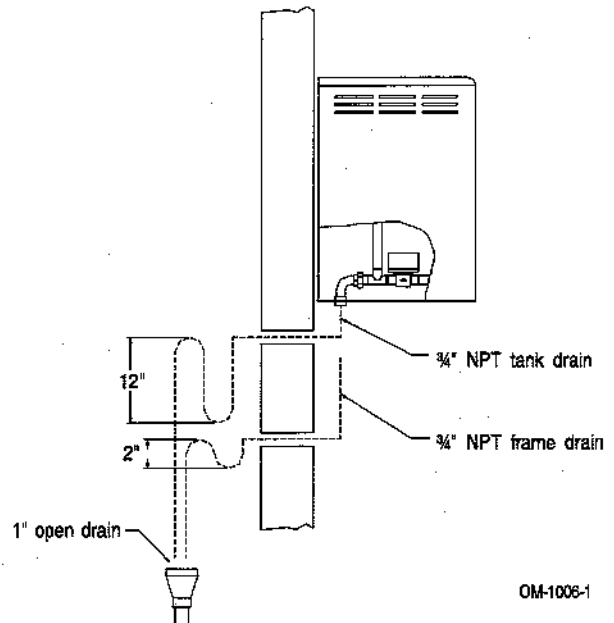

Figure 6-2: Drain Through or in Wall



Note: Locate the cabinet drain line exit away from the humidifier drain line exit, if possible. This will prevent water vapor from migrating up the cabinet drain line. Extending the cabinet drain line may be effective also.

WIRING

All wiring must be in accordance with all governing codes, and with the VAPORMIST® or VAPORMIST DI wiring diagram. The diagram is located inside the removable sub panel cover inside on the right-hand side of the humidifier cabinet.

The use of semiconductor fusing sized per the national electric code is recommended with the SSR option.

ELECTRICAL SPECIFICATIONS AND CAPACITIES/DIMENSIONS

Table 7-1: Electrical Specifications and Capacities

	VM-2	VM-4	VM-6	VM-8	VM-10	VM-12	VM-14	VM-16	VM-21	VM-25	VM-30	VM-34
Output per hour lb/gal/kg	6/7.2/7	12/14.5/4	18/2.2/8.2	24/2.9/10.9	30/3.6/13.6	36/4.4/16.3	42/5/19.1	50/6/22.7	64/7.7/29.0	75/9.1/34.0	91/10.9/41.4	102/12.4/46.2
Operating wt. lbs/kg	82/37	83/38	122/55	122/55	139/63	139/63	139/63	139/63	152/69	152/69	156/71	156/71
Shipping wt. lbs/kg	72/33	73/33	94/43	94/43	98/45	98/45	98/45	98/45	101/46	101/46	105/48	105/48
Amps @ 120v/1ø	16.7	-	-	-	-	-	-	-	-	-	-	-
*208v/1ø/3 wire	9.8	19.2	28.8	38.5	-	-	-	-	-	-	-	-
*230v/1ø***	8.0	16.0	24.0	31.9	39.9	-	-	-	-	-	-	-
*240v/1ø/3 wire	8.3	16.7	25.0	33.3	41.7	-	-	-	-	-	-	-
480v/1ø	4.2	8.3	12.5	16.7	20.8	25.0	29.2	33.3	43.8	-	-	-
600v/1ø	3.3	6.7	10.0	13.3	16.7	20.0	23.3	26.7	35.0	41.7	-	-
*208v/3ø/4 wire	-	16.7**	25.0**	33.3**	29.1**	33.3	38.9	44.4	-	-	-	-
240v/3ø/4 wire	-	14.4**	21.7**	28.9**	25.3**	28.9	33.7	38.5	-	-	-	-
400v/3ø	-	8.7**	13.0**	17.3**	15.2**	17.3	20.2	23.1	30.3	36.1	43.3	-
480v/3ø	-	7.2**	10.8**	14.4**	12.6**	14.4	16.8	19.2	25.3	30.1	36.1	40.9
600v/3ø	-	5.8**	8.7**	11.5**	10.1**	11.5	13.5	15.4	20.2	24.1	28.9	32.7
kW	2	4	6	8	10	12	14	16	21	25	30	34

* On 208/240 single-phase (3-wire) and 208 3-phase (4-wire) supplies, the neutral line may be utilized for 120 volt when used in conjunction with SDU fan unit. SDU 230v blower needs neutral line with 400v/3ø power.

** For wire sizing, the highest leg draw is shown due to current unbalance in some cases. All VAPORMISTs operate at 50/60 Hz.

*** Output capacity and kW derate of 7%.

Figure 7-1: VAPORMIST® Unit Dimensions

Back view

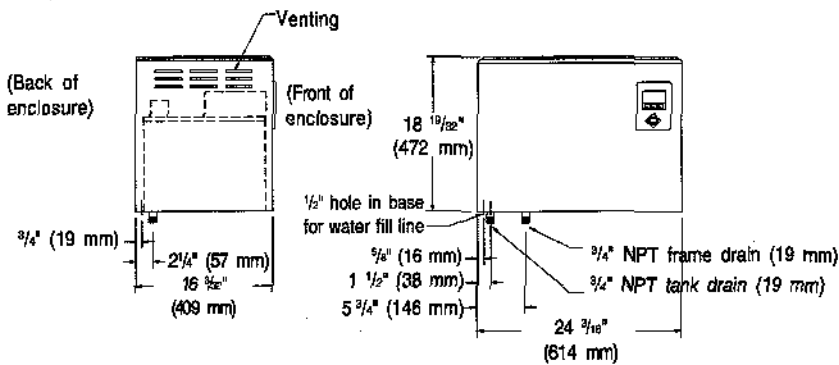

OM-282-3

Bottom view

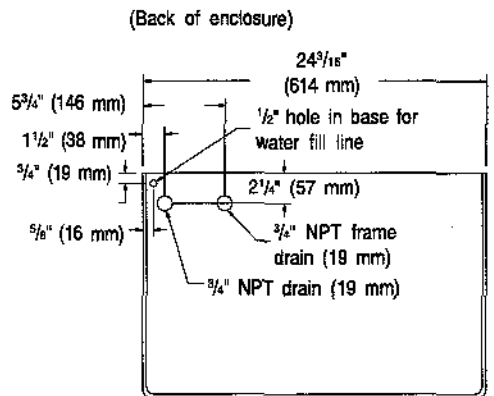

OM-282-2

Top view

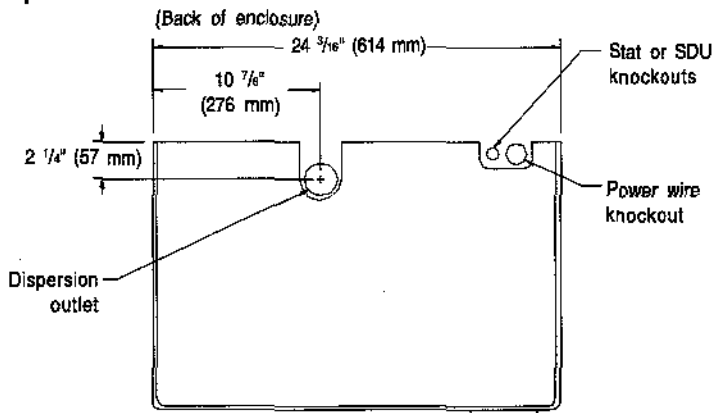

OM-282-1

AREA-TYPE APPLICATION USING SPACE DISTRIBUTION UNITS

The space distribution unit external (SDU-E) converts a VAPORMIST duct humidifier into an area-type humidifier. Instead of the steam dispersion tube being located inside an air duct, the dispersion tube is built into the fan unit. A fan draws in room air and blows it across the dispersion tube, where it disperses the moisture into the room. The SDU-E can be used on all models. The space distribution unit internal (SDU-I) can be used on models VM-2 through VM-10.

Mounting the SDU

The SDU may be mounted on a wall above the VAPORMIST cabinet or mounted on a wall remote from the VAPORMIST. Use the mounting template on the box for correct placement. Two 3/8" lag bolts are provided with each fan unit. (See page 4 for mounting instructions.)

Rise and Throw (SDU-E)

As steam is discharged from the humidifier, it quickly cools and turns to a visible fog that is lighter than air. As this fog is carried away from the humidifier by the airstream, it tends to rise toward the ceiling. If this fog contacts solid surfaces (columns, beams, ceiling, pipes, etc.) before it disappears, it could collect and drip as

water. The greater the space relative humidity, the higher and farther the fog will rise and throw before disappearing. The distances the fog travels before it disappears are given in table 8-1.

Table 8-1 lists the recommended minimum vertical (RISE), horizontal (THROW), and width (SPREAD) clearances for SDU-E area-type humidifiers at 40%, 50% and 60% RH in the space.

The SDU-E contains a 545 cfm blower (120/1/60) and an air flow proving switch field wired to the VAPORMIST humidifier electrical panel. A wiring diagram of the SDU-E is included with the unit.

On a call for humidity, the humidifier will begin producing steam and the start relay will energize the SDU blower. Time-delay is controlled by VAPOR-LOGIC[®] Microprocessor.

Table 8-1: SDU-E Visible Vapor Travel

Humidifier Size	40% RH		50% RH		60% RH	
	Rise* (ft/m)	Throw** (ft/m)	Rise* (ft/m)	Throw** (ft/m)	Rise* (ft/m)	Throw** (ft/m)
VM4	1/31	5/1.6	1.5/46	6.5/2.0	2.5/76	7.5/2.3
VM6	1/31	5/1.6	1.5/46	6.5/2.0	2.5/76	7.5/2.3
VM8	1/31	5.5/1.7	1.5/46	6.5/2.0	2.5/76	7.5/2.3
VM10	1.5/46	6/1.9	2.0/61	7.0/2.2	3.0/92	8.0/2.4
VM12	1.5/46	6/1.9	2.0/61	7.0/2.2	3.0/92	8.0/2.4
VM16	2/61	7/2.2	2.0/61	7.0/2.2	3.0/92	9.0/2.8
VM21	2/61	7.5/2.3	2.5/76	10.0/3.1	3.0/92	12.0/3.7
VM25	2/61	8/2.4	2.5/76	10.5/3.2	3.5/1.1	12.5/3.8
VM30	2/61	8/2.4	2.5/76	10.5/3.2	3.5/1.1	12.5/3.8
VM34	2/61	8/2.4	2.5/76	10.5/3.2	3.5/1.1	12.5/3.8

Table 8-1 Notes:

Table 8-1 states the vertical (rise), horizontal (throw), and width (spread) dimensions that can be expected with the VAPORMIST with SDU-E.

Surfaces cooler than ambient temperature, or objects directly in the path of visible vapor discharge, may cause condensation and dripping.

* Rise: Height visible vapor rises above discharge grill of the SDU-E.

** Throw: Maximum horizontal distance at which condensation occurs.

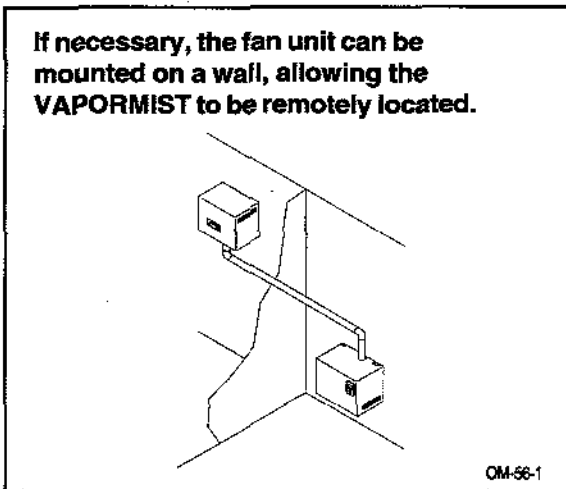
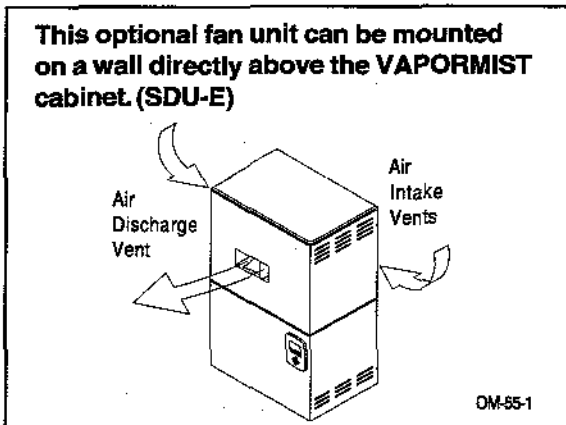

AREA-TYPE APPLICATION USING SPACE DISTRIBUTION UNITS

Figure 9-1: SDU-E Mechanical Detail

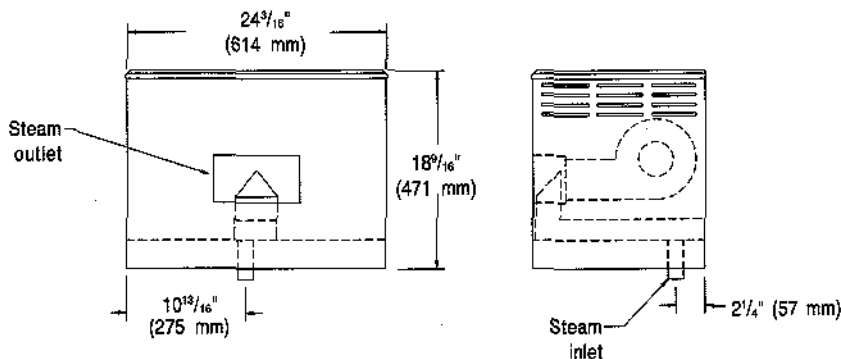

Field wiring is required to connect the SDU fan and air flow proving switch terminals to the respective VAPORMIST electrical panel terminals. Refer to the "external connections diagram" in the O&M package shipped with your unit.

OM-54-1

Instant absorption, no visible vapor

The space distribution unit internal absorption (SDU-I) is available for models VM-2 through VM-10.

Room air is drawn into the unit by a fan, where it is humidified with steam generated by electric heating elements, and then discharged back into the room with no visible vapor trail. Water vapor is instantly absorbed into the air making the VAPORMIST with an internal absorption SDU (SDU-I) ideal for application in finished spaces.

Figure 9-2: SDU-I Mechanical Detail

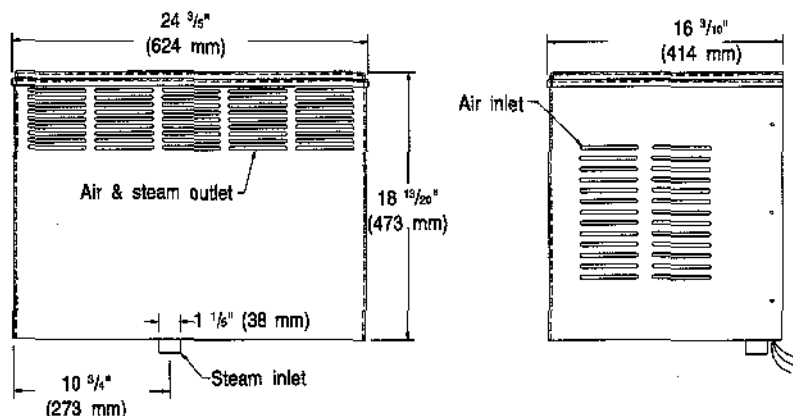

OM-2016

If SDU-E or SDU-I is immediately above the VAPORMIST®, disconnect both hose clamps on steam hose, grip hose and rotate to break it loose from the tubing, then slide the hose up onto the SDU steam tube until sufficient clearance is provided to move the tank.

START-UP AND OPERATION

Introduction

After the system has been properly installed and connected to both electrical and water supplies, it may then be started.

Start-up and Checkout Procedures

Mounting

Check mounting to see that the unit is level and securely supported before filling with water.

Piping

Verify that all piping connections have been completed as recommended and that water pressure is available.

Electrical

Verify that all wiring connections have been made in accordance with all governing codes and the enclosed VAPORMIST® wiring diagram. The external connections diagram will be found with this IOM packet.

Caution: Only qualified electrical personnel should perform start-up procedure.

Figure 10-1: Electronic Probe Control for Maintaining Proper Water Level (VAPORMIST only)

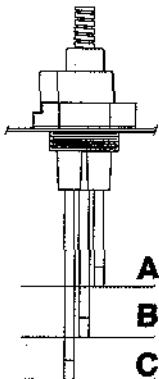

A simple three-probe conductivity sensor cycles a solenoid-operated water fill valve to maintain the proper water levels.

VAPOR-LOGIC₃ Control

The VAPOR-LOGIC₃ is the standard controller for the VAPORMIST. For more information regarding the operation of the VAPOR-LOGIC₃ microprocessor, see the *VAPOR-LOGIC₃ Installation Instructions and Operations Manual*.

VAPORMIST Makeup Water Piping

Use cold or hot make-up water. If the water pressure is above 60 psi and/or water hammer would be objectionable, a pressure-reducing valve or shock arrester should be installed. Even though the VAPORMIST has an internal 1" air gap, some local codes may require a vacuum breaker. **Important:** Minimum water supply pressure is 25 psi.

VAPORMIST DI Makeup Water Piping

In this unit the electronic probe control is replaced by a float valve control.

A float switch provides this device heater protection in the event of a low-water condition and is common to all DI humidifiers. The wiring diagram is located inside the electrical panel cover.

Control System Start-Up/Checkout

1. Confirm that proper grounding and an approved earth ground are provided.
2. Confirm that the control signal being connected to the VAPOR-LOGIC₃ system is compatible with the VAPOR-LOGIC₃ program. Identify the VAPOR-LOGIC₃ program code on the wiring diagram. Refer to the VAPOR-LOGIC₃ manual to decipher the code using the nomenclature description on page 8.
3. Confirm all wiring is correct per wiring diagram.
4. Confirm J17, J18 and J19 shunt connectors on VAPOR-LOGIC₃ board are in their correct position per wiring diagram. See page 3 for the physical locations.
5. Confirm that the keypad is mounted on the VAPORMIST with modular cable routed away from high voltage circuits and connected to J2 female connector on control board.
6. Turn on water supply. Confirm drain valve is closed.
7. Turn on power. The keypad will display the introduction of VAPOR-LOGIC₃ and then enter AUTO mode.
8. System will initiate filling of the tank with water. The keypad will display "Filling" as part of the idle screen information.
9. Airflow switch input must be closed.
10. High limit humidistat input must be closed or Variable Air Volume (VAV) control system high limit transmitter must be connected.
11. Sufficient water in the tank, air flow switch closed, high limit humidistat closed, door interlock circuit (optional) closed and a call for humidity will activate the heat output. **If the tank does not contain water and the heat output is activated by the VAPOR-LOGIC₃ control system, a serious failure will result. Immediately remove power from the system and verify that all wiring is done per the wiring instructions in the manual and the unit wiring diagram.**
12. During normal operation, the keypad will display humidifier operating status. See the VAPOR-LOGIC₃ IOM for descriptions to change any of the operating parameters.

MAINTENANCE

Inspect after first three months of duty. The best way to determine how often your particular system will need maintenance is to remove the cover and inspect it after its first three months of duty. Potable water carries a variety of minerals and other materials in a mix that varies from location to location. This variation in water quality, combined with the hours of operation and duty cycle, will determine your own unique maintenance schedule.

Water quality makes a difference

1. Light to moderately hard water (2 to 10 grains hardness per gallon)
 - annual cleaning
 - regular skimming
2. High mineral content water (more than 10 grains hardness per gallon)
 - cleaning frequency determined by use and water quality
 - regular skimming
 - periodic drain and flush cycles
3. DI/RO water (Model VMDI)
 - no regular cleaning required (although regular inspections are advised)
 - no regular skimming or drain and flush cycles required
 - the presence of chlorides in DI water will eventually cause pitting and failure of the tank and its components
4. To dramatically reduce mineral accumulation inside the evaporating chamber, softening of the makeup water is recommended. (Solids like silica are not removed in the softening process.)

Proper skimming, draining and flushing

1. Skimming will remove most water impurities at the surface, ensuring proper surface tension and an even boil. Skimming will remove most entrained contaminants that have not yet precipitated as scale.
2. Draining and flushing will completely remove entrained contaminants and assist in removing precipitated contaminants like scale and silica.

To inspect and service

1. Remove the evaporating chamber
 - Remove the two fasteners on each side of the cover enclosure.
 - Remove the enclosure.
 - **Do not remove the electrical panel cover or heater terminal cover until electrical power is disconnected. Safety first.**
 - If the VAPORMIST has an SDU mounted directly above it, the SDU cover must be removed before removing the unit cover.

- If the tank is hot, cool it down by moving the valve lever located on the back of the drain valve to the manual open position – the fill valve will eventually open allowing cool water to run through the tank until it is cool enough to handle.
 - Shut off the water supply.
 - Shut off the electrical supply.
 - Allow the tank to completely drain.
 - Disconnect the fill line at the supply side of the fill valve.
 - Disconnect the electrical plugs between the tank components and the back of the electrical panel (includes: power plug, fill plug, drain plug, water level control plug, tank temperature sensor plug and thermal trip plug). **DISCONNECT BY PULLING ON PLUG HOUSING. DO NOT DISCONNECT BY PULLING ON CORD OR WIRES.**
 - Disconnect the drain union on the back left corner of the frame.
 - Disconnect the steam supply hose from the top of the tank.
 - Lift the tank foot above the frame flange and slide the tank assembly forward to remove.
2. Loosen the four cover bolts and remove the cover assembly from the tank.
 3. Clean the tank interior using a putty knife or similar flat instrument.
 4. Unscrew the probe rod assembly and clean the probe cup, ensuring that all passageways are clear. Clean the probe rods using steel wool or a similar mild abrasive material. Inspect the composite plastic probe rod holder for any signs of cracking, roughness, or deterioration. If found, replace.
 5. Install the probe and probe plug assembly. Verify ground wire.
 6. Secure the chamber cover, making sure the cover gasket is seated and the chamber is sealed.
 7. Re-install the evaporating chamber.
 - Reconnect the fill line.
 - Reconnect the electrical plugs.
 - Reconnect the drain union.
 - Reconnect the vapor hose.
 8. Move the drain valve lever back to the auto position.
 9. Turn on the water supply. Turn on the electrical power.

MAINTENANCE

Off Season Shut-Down

1. Switch off electrical power.
2. Remove enclosure.
3. Shut off water supply to make-up valve.
4. Drain evaporation chamber, and clean if necessary (see "Cleaning the Evaporating Chamber" above).
5. Replace enclosure.
6. Leave chamber dry, the power "OFF," and the water shutoff valve closed until the next humidification season.

VAPORMIST DI

The VAPORMIST DI unit uses DI/RO water. Because these water types are mineral-free, cleaning of the evaporator chamber should not be necessary. However, there are some simple maintenance steps that should be followed to ensure all parts of the unit are in working order.

To inspect and service

1. Remove the evaporating chamber.
 - Remove the two fasteners on each side of the cover enclosure.
 - Remove the enclosure.
 - **Do not remove the electrical panel cover or heater terminal cover until electrical power is disconnected. Safety first.**
 - If the VAPORMIST has an space distribution unit (SDU) mounted directly above it, the SDU cover must be removed before removing the unit cover.
 - If the tank is hot, cool it down by opening the manual ball valve on the side of the tank. The float valve will open allowing cool water to run into the tank until it is cool enough to handle.
 - Shut off the water supply.
 - Shut off the electrical supply.
 - Allow the tank to drain completely.
 - Disconnect the fill line at the fill fitting.
 - Disconnect the electrical plugs between the tank components and the back of the electrical panel (includes: power plug, low water switch plug, tank temperature sensor plug and thermal trip plug).
DISCONNECT BY PULLING ON PLUG HOUSING. DO NOT DISCONNECT BY PULLING ON CORD OR WIRES.
 - Disconnect the drain union on the back left corner of the frame.
 - Disconnect the steam supply hose from the top of the tank.
 - Lift the tank foot above the frame flange and slide the tank assembly forward to remove.

2. Loosen the four cover bolts and remove the cover assembly from the tank.
3. Inspect the tank interior for debris or pitting.
4. Inspect the valve inlet for debris.
5. Check the operation of the float valve and the condition of the float seat.
6. Check the low water switch for free operation.
7. Secure the chamber cover making sure the cover gasket is seated and the chamber is sealed.
8. Reinstall the evaporating chamber.
 - Reconnect the fill line.
 - Reconnect electrical plugs.
 - Reconnect drain union.
 - Reconnect vapor hose.
9. Close the drain valve.
10. Turn on the water supply. Turn on the electrical power.

Off-Season Shut-Down Procedure

1. Switch off electric power.
2. Remove enclosure.
3. Shut off water supply to make-up valve.
4. Drain evaporating chamber by opening the drain valve. For units with end-of-season drain, please refer to VAPOR-LOGIC[®] IOM.
5. Replace enclosure.
6. Leave chamber dry, power off, and water shut off valve closed until the next humidification season.

VAPORMIST® TROUBLE-SHOOTING GUIDE

PROBLEM	POSSIBLE CAUSE	RECOMMENDED ACTION
Humidifier does not heat.	Incorrect or non-existent supply voltage to unit	Check main line safety switch . Check main line fuses. Check for proper supply voltage.
	Incorrect or non-existent control voltage	Reset control transformer circuit breaker. Check for 24 VAC control circuit voltage at T-1 and T-2 on the control board.
	Humidistat not calling	Set humidistat to call. Inspect for faulty humidistat.
	Safety controls open.	Check safety controls, air flow switch, and high limit humidistat.
Humidifier will not fill.	No water pressure at valve	Check water supply/shut off valves.
	Faulty water fill valve	Check for 24 volts at the fill valve.
	Plugged strainer	Check strainer.
	Plugged valve	Check valve.
	Faulty control board	Verify control voltage across the fill valve output.
Humidifier does not stop filling.	Lack of tank to probes' electrical continuity; water conductivity 100 micromhos/cm (2 gr/gal) min.	Add salt to the tank. If this solves the problem, consult factory for further advice.
	Fill valve stuck open	Check valve for foreign matter.
	Drain valve not closed Fill valve installed backward	Check for correct water flow, through valve, note arrow.
	Auto-drain mode	Humidifier may be in periodic drain and flush. Check controller display.
Low output	Electric drain valve not seating	Correct cause of leakage or replace valve.
	Fill valve stuck open	Check valve for foreign matter.
Unit short cycles	Controller cycle rate set to low	Review controller cycle set point.
Reduced or no output even though water is at the proper level.	Heater malfunctioning	Verify that proper voltage is being applied to heaters. Check heater amp draw and compare to wiring diagram ratings.
	Malfunctioning control system	Heater contactor not functioning, replace. Service fuses blown. Auxiliary limit controls not allowing system to operate (dust humidistat, air flow proving switch, etc.) Reset, replace or calibrate as required. Faulty or inaccurate humidistat, replace or calibrate.

*Probe rod corrosion or probe head material aging may cause level control system failure. This generally does not occur in the first two years of operation.

VAPORMIST® DI TROUBLE-SHOOTING GUIDE

PROBLEM	POSSIBLE CAUSE	RECOMMENDED ACTION
Humidifier will not heat.	Control transformer	Reset control transformer circuit breaker.
	Humidistat is not calling	Set humidistat to call. Inspect for faulty humidistat.
	Safety controls open	Check safety controls, air flow switch, high limit humidistat, etc.
	Low water cutoff	Check at board 32 and 33. Measure 0 volts for closed switch, approximately 2.5 volt for A.C. open switch.
Humidifier will not fill.	No water pressure at valve	Check manual water supply. Valve, minimum 25 psi water pressure.
	Malfunctioning float switch	Check to make sure that float moves freely on stem.
	Plugged fill valve	Check fill valve inlet.
Humidifier does not stop filling.	Open drain valve	Obstruction in drain valve will not allow complete closure. Clean or replace valve.
	Manual drain valve not closed	Close drain valve.
	Fill valve stuck open	Check valve for foreign matter, water-logged float, broken float arm, or worn valve stopper.
Reduced or no output even though water is at the proper level.	Heater malfunctioning	Verify that proper voltage is being applied to heaters. Check heater (amp draw and compare to wiring diagram ratings).
	Malfunctioning control system	Heater contactor not functioning, replace. Service fuses blown. Auxiliary limit controls not allowing system to operate (dust humidistat, air flow proving switch, etc.) Reset, replace or calibrate as required. Faulty or inaccurate humidistat, replace or calibrate.

REPLACEMENT PARTS

Table 15-1: Space Distribution Unit (SDU-E)

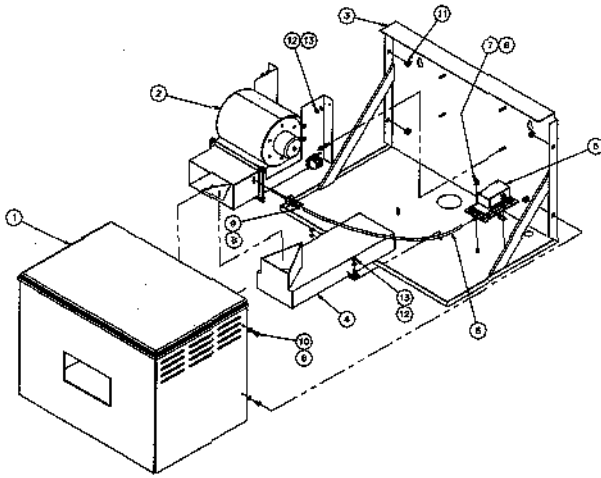

sduextassy-om

No.	Description	Qty.	Part No.
1	Cabinet base, SDU-E	1	330000-003
2	Blower, SDU99 external assembly	1	409540-003
3	Frame, SDU external	1	165542
4	Dispersion chamber, SDU99 w/1 1/2" out	1*	160445-001
4	Dispersion chamber, SDU99 w/2" out	1*	160445-002
5	Switch, air flow	1	406190
6	Tubing, 1/4" PVC plastic tubing	1	405722
7	Nut, 8-32 x 3/8"	2	700200-002
8	Star washer, 8-32	6	700200-003
9	Screw, self tapping 8-32 x 3/8"	4	700000-005
10	Screw, 8-32 x 1/2 panhead Phillips F	4	700170-007
11	Cage clip, 8-32	4	409593-001
12	Nut, 1/4-20 Hex	10	700300-016

* Specify model size when ordering.

Table 15-2: VAPORMIST® Subpanel with SDU-E

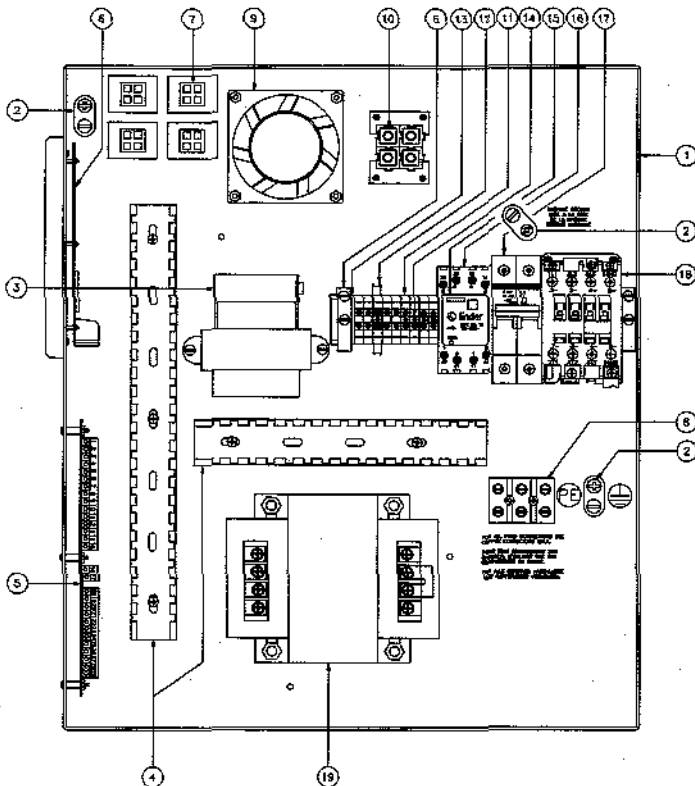

om-213-3

No.	Description	Qty.	Part No.
1	Subpanel, VM99 barrier	1	120801
2	Ground lug, L-35 10-14 GA CP-8	1	409250-017
2	Ground lug, L-70 6-8 GA CP-4	1	409250-018
3	Transformer 600V	1	408986
3	Transformer 120/240/480/208	1	408965-001
4	Channel, wire with cover	2	408999-003
5	Main board, VL-3	1	408490-001
6	Keypad board, VL-3	1	408490-002
7	Plug, 4 prong female	4	409585-008
8	3 Pole 3ø, power block	1	408300-002
8	2 Pole 1ø, power block	1	408300-001
9	Fan, 24 volt	1	408677-001
10	Power plug	4	409585-001
11	Terminal	8	408252-001
12	Terminal, ground	1	408252-010
13	Terminal, end plate	1	408252-005
14	Terminal, jumper	2	408252-008
15	Relay finders	1	407900-006
16	Relay finders, base	1	407900-007
17	Breaker, 2 pole 1.5A 480V	2	406775-001
17	Breaker, 2 pole 1.5A 600V	1	406775-003
18	Contactors, 60A	1	407001-021
18	Contactors, 32A	1	407001-020
19	Transformer, 480V 300VA	1	408991
19	Transformer, 575V 300VA	1	408992
19	Transformer, 480V 500VA	1	408996-008
19	Transformer, 600V 500VA	1	408996-009

REPLACEMENT PARTS

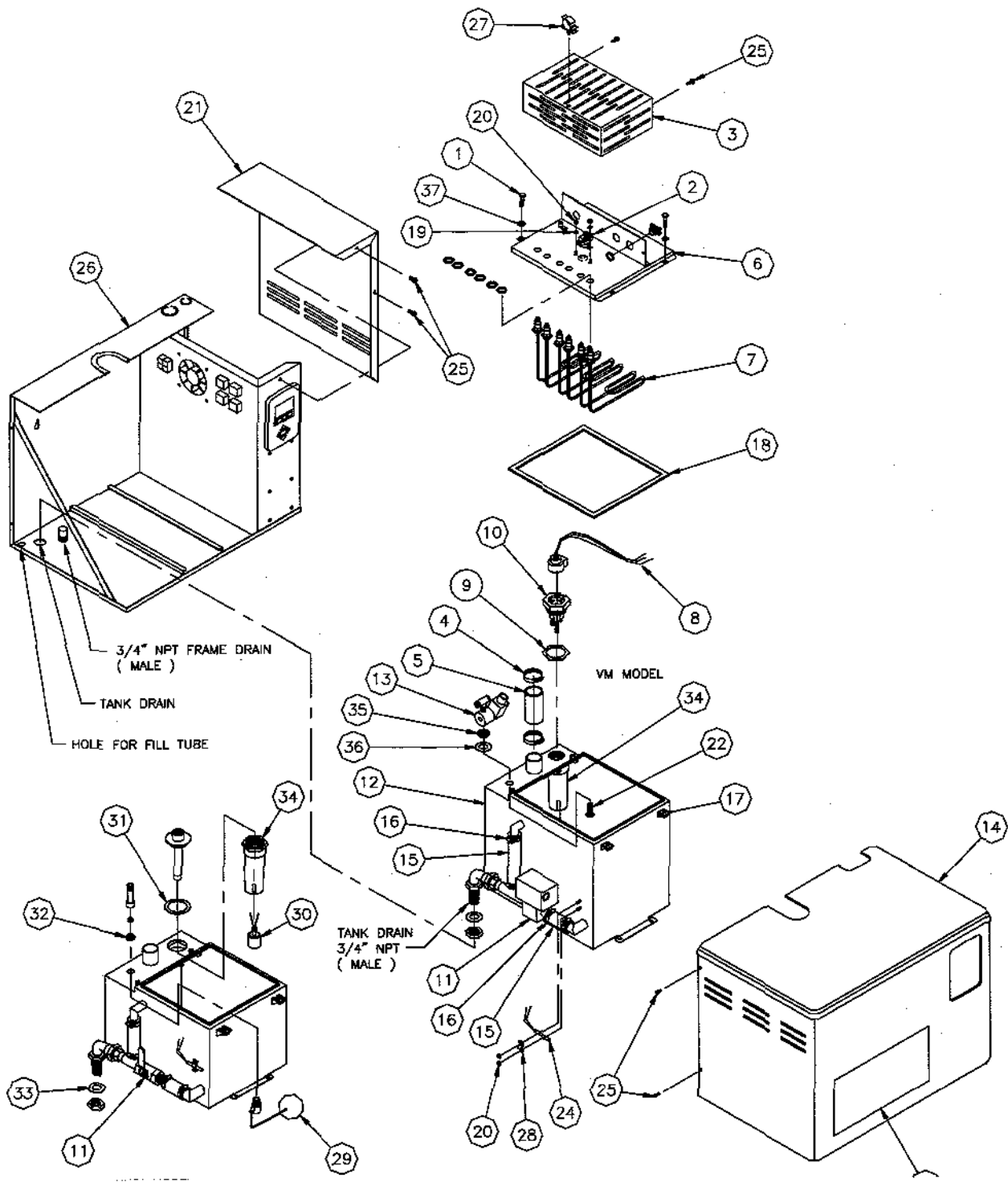

REPLACEMENT PARTS

Table 17-1: VAPORMIST® (see drawing on page 16)

No.	Description	Qty.	Part No.
1	Head bolt, large Phillips, ¼ - 20 X 1"	4	700300-013
2	Thermo cut-out	1	409560-001
3	Cover, heater terminal	1	*
4	Hose clamp, 2"	2	700560-200
5	Hose cuff, 1½"	1	305390-006
5	Hose cuff, 2"	1	305391-006
6	Cover, tank	1	*
7	Heater element	*	*
8	Probe assembly with cord and plug	1	406050-005
9	Probe assembly gasket	1	309750-004
10	Probe assembly, VM 2-4	1	406270
10	Probe assembly, VM 6-34	1	406275
11	Valve, ¾" electric, 24V	1	505400-001
11	Valve, ½" SST ball	1	505000-003
11	Drain, ¼" NPT E.O.S., 24V solenoid SST w/DIN plug (not shown)	1	505086-003
12	Tank weldment	1	*
13	Valve, ¼" solenoid, 24V w/DIN plug	1	505084-001
14	Cabinet enclosure	1	330000-001
15	Hose, ¾" ID	1	307020-002
16	Hose clamp, ¾"	4	700560-075

* Specify humidifier model and serial numbers when ordering.

REPLACEMENT PARTS

Table 17-1 continued: VAPORMIST® (see drawing on page 16)

No.	Description	Qty.	Part No.
17	Nut assembly, ¼-20, VM/VMDI 2-4	4	700650
17	Nut assembly, ¼-20, VM/VMDI 6-34	2	700650
18	Cover, tank gasket	1	*
19	Washer, #8 external tooth, pltd	2	700200-003
20	Nut, #8-32 hex, pltd	6	700200-002
21	Cover, subpanel	1	120277
22	Fill adapter, VM 2-4	1	160226-041
22	Fill adapter, VM 6-16	1	160224-041
22	Fill adapter, VM 21-34	1	160224-052
23	Panel, insulation	1	309845-003
24	Sensor, temperature	1	405760
25	Screw, Phillips head, #8-32 X ½"	8	700170-007
26	Frame assembly, chassis	1	165541
27	Clip, wire harness	1	405892-001
28	Clip, temperature sensor	1	408251
29	Valve assembly, float	1	505310
30	Switch, float, 1/8" NPT	1	408420-002
31	Gasket, 2.50 OD X 1.90 ID	1	309750-004
32	Ring, seal, ¼"-18 NPT	1	306365
33	Gasket, bulkhead, 1.60 OD X 1.15 ID	1	309750-005
34	Probe housing, nylon, VM	1	308500
35	Nut, VM heater .475	1	409601-001
35	Nut, VM heater .375	1	409602-001
36	Gasket, VM heater .475	1	409601-002
36	Gasket, VM heater .375	1	409602-002

* Specify humidifier model and serial numbers when ordering.

REPLACEMENT PARTS

Table 19-1: VAPORMIST® subpanel with SSR

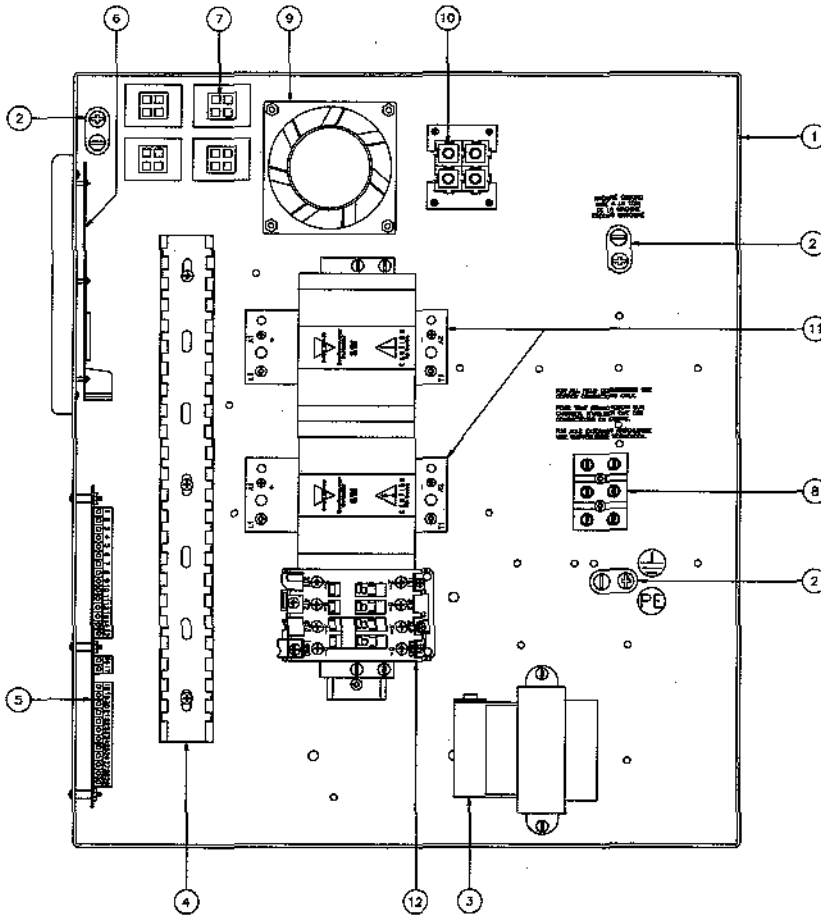

No.	Description	Qty.	Part No.
1	Subpanel, VM99 barrier	1	120801
2	Ground lug, L-35 10-14 GA CP-8	1	409250-017
2	Ground lug, L-70 6-8 GA CP-4	1	409250-018
3	Transformer 600V	1	408986
3	Transformer 120/208/240/480	1	408965-001
4	Channel, wire with cover	2	408999-003
5	Main board, VL-3	1	408490-001
6	Keypad board, VL-3	1	408490-002
7	Plug, 4 prong female	4	409585-008
8	3 Pole 3ø, power block	1	408300-002
8	2 Pole 1ø, power block	1	408300-001
9	Fan, 24 volt	1	408677-001
10	Power plug, 4	4	409585-001
11	SSR, 480 VAC 50 AMP 1 Pole	2	408677-002
12	Contactor, 60A	1	407001-021
12	Contactor, 32A	1	407001-020

TWO-YEAR LIMITED WARRANTY

DRI-STEEM Humidifier Company ("DRI-STEEM") warrants to the original user that its products will be free from defects in materials and workmanship for a period of two (2) years after installation or twenty-seven (27) months from the date DRI-STEEM ships such product, whichever date is the earlier.

If any DRI-STEEM product is found to be defective in material or workmanship during the applicable warranty period, DRI-STEEM's entire liability, and the purchaser's sole and exclusive remedy, shall be the repair or replacement of the defective product, or the refund of the purchase price, at DRI-STEEM's election. DRI-STEEM shall not be liable for any costs or expenses, whether direct or indirect, associated with the installation, removal or re-installation of any defective product.

DRI-STEEM's limited warranty shall not be effective or actionable unless there is compliance with all installation and operating instructions furnished by DRI-STEEM, or if the products have been modified or altered without the written consent of DRI-STEEM, or if such products have been subject to accident, misuse, mishandling, tampering, negligence or improper maintenance. Any warranty claim must be submitted to DRI-STEEM in writing within the stated warranty period.

DRI-STEEM's limited warranty is made in lieu of, and DRI-STEEM disclaims all other warranties, whether express or implied, including but not limited to any IMPLIED WARRANTY OF MERCHANTABILITY, ANY IMPLIED WARRANTY OF FITNESS FOR A PARTICULAR PURPOSE, any implied warranty arising out of a course of dealing or of performance, custom or usage of trade.

DRI-STEEM SHALL NOT, UNDER ANY CIRCUMSTANCES BE LIABLE FOR ANY DIRECT, INDIRECT, INCIDENTAL, SPECIAL OR CONSEQUENTIAL DAMAGES (INCLUDING, BUT NOT LIMITED TO, LOSS OF PROFITS, REVENUE OR BUSINESS) OR DAMAGE OR INJURY TO PERSONS OR PROPERTY IN ANY WAY RELATED TO THE MANUFACTURE OR THE USE OF ITS PRODUCTS. The exclusion applies regardless of whether such damages are sought based on breach of warranty, breach of contract, negligence, strict liability in tort, or any other legal theory, even if DRI-STEEM has notice of the possibility of such damages.

By purchasing DRI-STEEM's products, the purchaser agrees to the terms and conditions of this limited warranty.

DRI-STEEM[®]
HUMIDIFIER COMPANY



14949 Technology Drive • Eden Prairie, MN 55344
Phone: (800)328-4447 • (612)949-2415 • Fax: (612)949-2933
E-Mail: sales@dristeem.com • Web: www.dristeem.com

Europe Office:

Bell Place, Bell Lane • Syresham, Brackley • NN13 5HP, U.K.
Phone: +44 1280 850122 • Fax: +44 1280 850124
E-Mail: 106277.1443@compuserve.com



Printed on recycled paper. Minimum
10% Post Consumer Waste.

Continuous product improvement is a policy of DRI-STEEM Humidifier Company therefore, product features and specifications are subject to change without notice.

DRI-STEEM, RAPID-SORB, VAPORMIST, VAPOR-LOGIC, are Registered Trademarks of the DRI-STEEM Humidifier Company.
TEFLON is a Registered Trademark of Dupont.

M 990M - 0999

READ AND SAVE THESE INSTRUCTIONS

replace with 0600

VAPORMIST® and VAPORMIST® DI ELECTRIC STEAM HUMIDIFIERS

**Installation Instructions
and
Maintenance Operations
Manual**

**For Toll-Free Technical Support,
Call 1-800-328-4447**



ETL LISTED



cETL LISTED

DRISTEEM®
HUMIDIFIER COMPANY

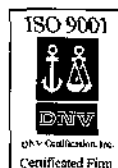

TABLE OF CONTENTS

TO THE PURCHASER AND INSTALLER

Thank you for purchasing our VAPORMIST® humidifier. We have designed and built this equipment to give you *complete satisfaction and trouble-free service* for many years. Familiarizing yourself with this manual will help ensure you proper operation of the equipment for years to come.

This manual covers the installation and maintenance procedures for both the VAPORMIST and VAPORMIST DI humidifiers.

DRI-STEEM Humidifier Company

VAPORMIST Humidifier	3
Installation	
Locating and Mounting the VAPORMIST Humidifier	4
Examples of Mounting the Dispersion Tube	4
Mounting Dispersion Tube with Condensate Drain Line	5
Connecting Dispersion Tube and Humidifier	5
Piping and Wiring	6
Electrical Specifications and Capacities/Dimensions	7
AREA-TYPE Application Using Space Distribution Units (SDU-E and SDU-I)	8
Start-up and Operation	10
Maintenance	11
VAPORMIST Trouble-Shooting Guide	13
VAPORMIST DI Trouble-Shooting Guide	14
Replacement Parts	15
Two-Year Limited Warranty	20

VAPORMIST® HUMIDIFIER

Figure 3-1: VAPORMIST Humidifier

The standard VAPORMIST unit requires water conductivity of at least 100 micromhos/centimeter (2 grains per gallon) to operate. It will not operate with water treated by reverse osmosis or deionization processes. (See DI model below.)

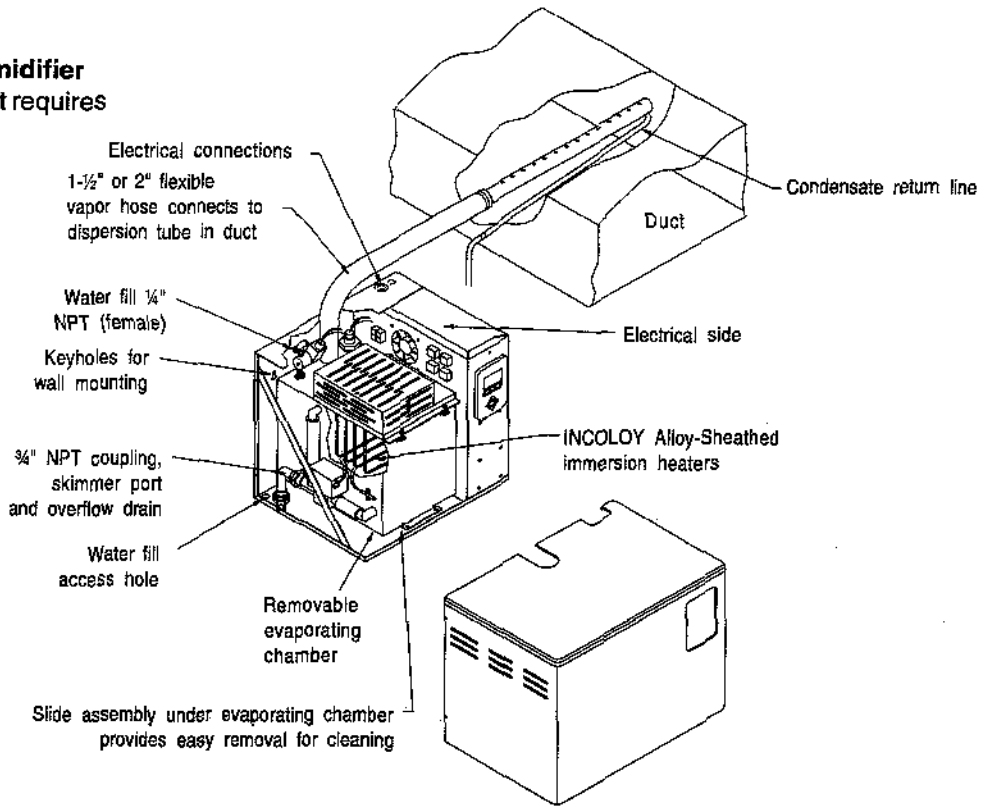

OM-82-4

Figure 3-2: VAPORMIST DI Humidifier (Deionized Water)

The VAPORMIST DI humidifier shown here is specifically designed for use with deionized or reverse osmosis water.

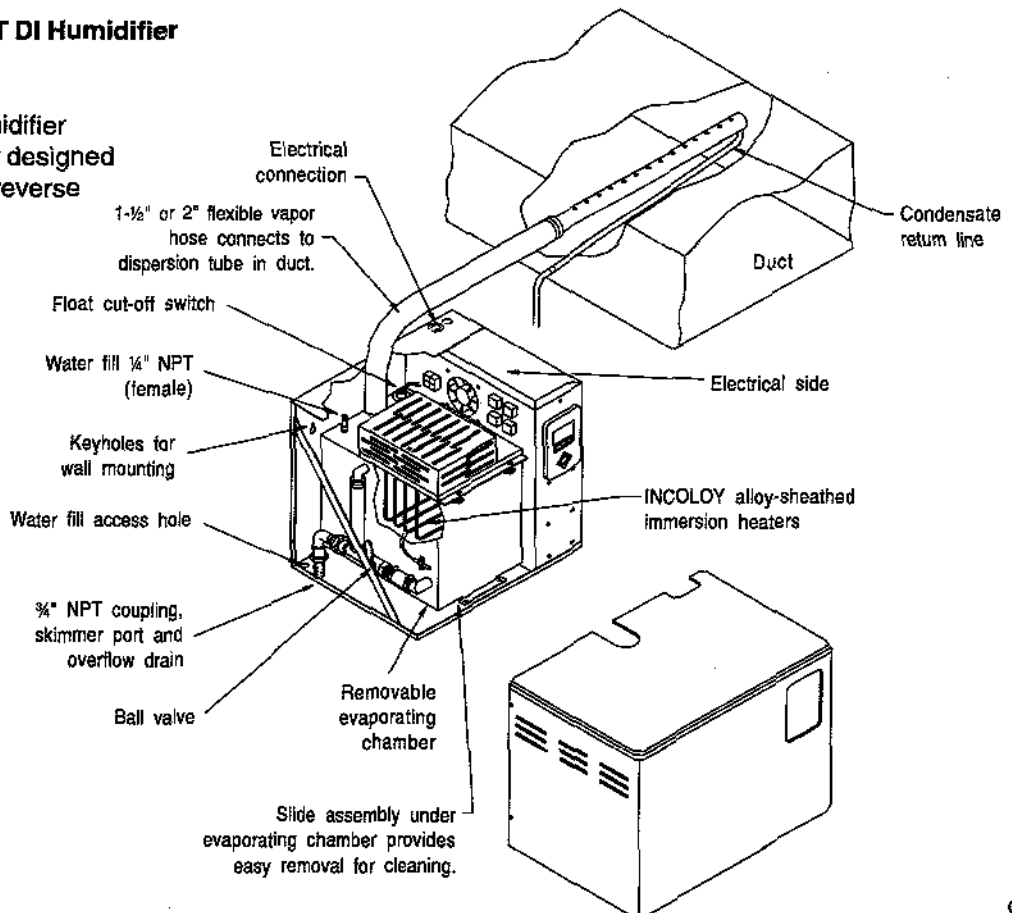

OM-82-5

INSTALLATION

Locating and Mounting the VAPORMIST® Humidifier

The VAPORMIST humidifier is designed to lag bolt to the wall, and it should be installed in a space located near an air duct system.

Consider the following when selecting the location of the humidifier:

- Convenient access to duct
- Electrical and plumbing connections
- Required clearances

The mounting location should provide a minimum clearance of 36" to the front and 24" to the right side of the unit. This clearance is required for removing the evaporating chamber and accessing the electrical compartment. Also, a minimum clearance of 6" to the left side is required for louvers and enclosure fasteners.

Examples of Mounting the Dispersion Tube

Figure 4-1: Mounted Horizontally in Duct

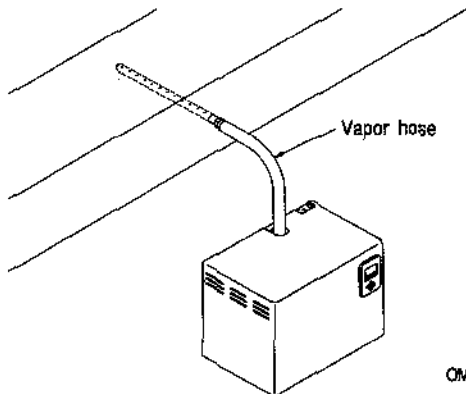

Vapor hose and dispersion tube should be pitched back to the humidifier with a gradual slope of 2" per foot (minimum). A single dispersion tube cannot be used with VM-30 or VM-34.

Figure 4-2: Mounted Horizontally in Duct and Lower than VAPORMIST Unit

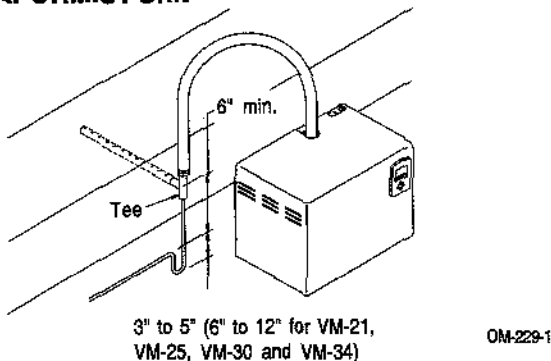

A water seal must be located in drain line as shown to maintain steam pressure. A single dispersion tube cannot be used with VM-30 or VM-34.

Electrical power supply, water make-up piping and drain piping must also be considered. Electrical power supply connections are made at the lower or upper right rear corner of the unit. Water makeup and draining piping connections are made at the lower left rear corner.

When mounting on a stud wall (studs 16" on center), locate studs and position lag bolts in place so that each of the two lags (16" apart) will center on a stud. Mark hole locations and pre-drill 1/4" diameter pilot holes using mounting template on VAPORMIST box. Secure frame to wall with lag bolts provided.

For hollow block or poured concrete wall mounting, position template in place and mark the holes. Drill appropriate pilot hole for two 3/8" toggle bolts or two 3/8" machine bolt lead anchors. Secure frame in place.

Figure 4-3: Mounted Vertically (Optional)

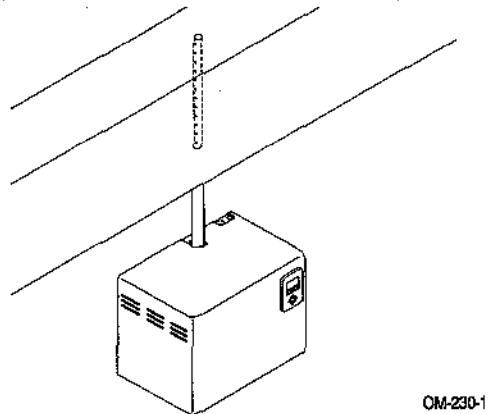

This is not recommended on models VM-10 through VM-34.

IMPORTANT NOTES: When duct is located more than 10 feet away from unit, vapor hose is not recommended; 1½" minimum I.D. hard pipe should be used instead. VM-30 and VM-34 must use a multiple tube steam dispersion system.

Note: Following models require a minimum of:

VM2-10:	up to 30 lbs/hr	1½" hose kit without drain
VM12-16:	up to 57 lbs/hr	1½" hose kit with drain
VM12-16:	up to 57 lbs/hr	2" hose kit without drain
VM21-25:	up to 85 lbs/hr	2" hose kit with drain
VM30-35:	require multiple tube assemblies	

INSTALLATION

Figure 5-1: Single Tube

VAPORMIST® Mounting Tube with Condensate Drain Line

- Mount dispersion tube level.
- Orient dispersion tube so that tubelets are pointed straight up.

Connecting Dispersion Tube to Humidifier

- Connection can be made with vapor hose or hard piping.
- Hard piping should have a minimum I.D. of 1½".
- A minimum pitch of 2" per foot back to the humidifier should be maintained.
- Short sweep 90° elbows are not recommended; use two 45° elbows 12" apart or long sweep 90° elbows instead.
- Thin-walled tubing will heat up faster than heavy-walled pipe, causing less steam loss at start-up.
- Insulating hard piping will reduce the steam output loss caused by condensation.
- When mounting the humidifier above the level of dispersion tube, see figure 4-2 on page 4.

Failing to follow these recommendations may result in excessive back pressures being imposed on the humidifier. This may lead to dispersion tube(s) spitting, steam blowing through water seals, or leaking gaskets. When the distance between humidifier and the dispersion tube(s) exceeds 20 feet, consult factory for recommendations.

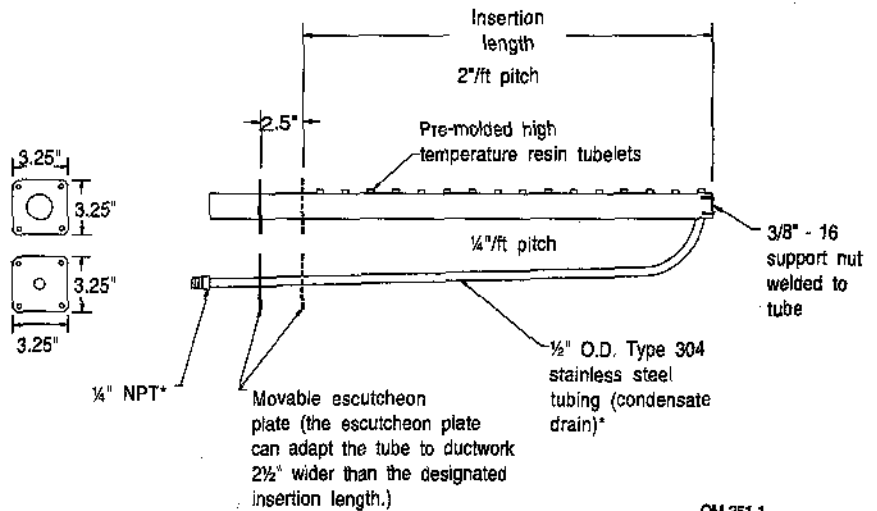

OM-351-1

Figure 5-2: RAPID-SORB® with Condensate Wasted to Floor Drain

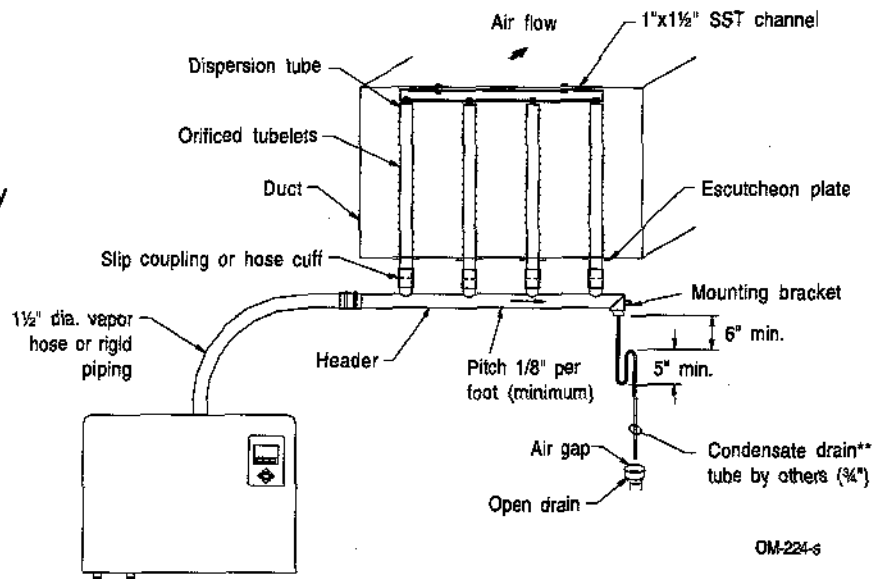

OM-224-6

Notes:

* ½" diameter condensate tubing is not needed nor provided when steam flow is 34 lbs per hour or less per dispersion tube. A minimum pitch of 2" per foot back to the humidifier should be maintained.

** Condensate drain tubing material must be suitable for 212°F (100°C) water.

PIPING AND WIRING

Water make-up piping may be of any code-approved material (copper, steel, or plastic). The final connection size is 1/4" NPT. In cases where water hammer may be a possibility, a shock arrestor should be considered.

Drain piping may be of any code-approved material (copper, steel, or plastic rated for 212°F minimum). If drainage by gravity is not possible, a small lift pump should be used. (DRI-STEEM part #400280.)

The final connection sizes are 3/4" NPT for drain fitting and frame drain. This connection size should not be reduced. (See figures 6-1 and 6-2 for proper drain piping configurations.) The evaporator drain should be piped and discharge into a floor drain. Combining the two drain pipes into a single drain line may result in the backflow of drain water into the humidifier cabinet, causing the unit to malfunction.

Figure 6-1: Drain Adjacent to Wall

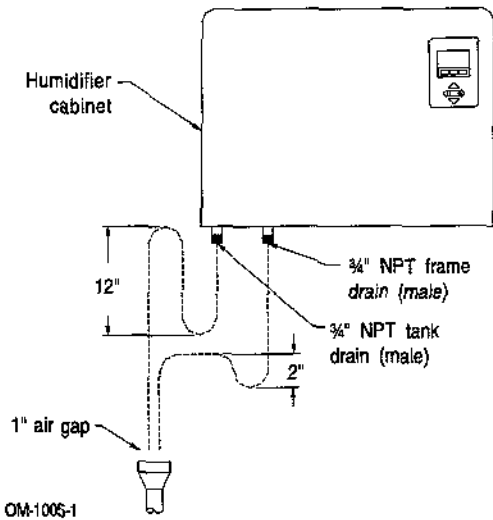
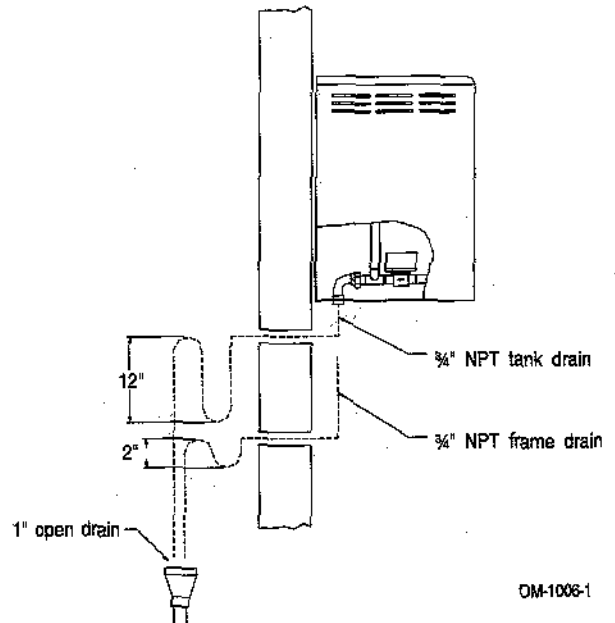

Figure 6-2: Drain Through or in Wall



Note: Locate the cabinet drain line exit away from the humidifier drain line exit, if possible. This will prevent water vapor from migrating up the cabinet drain line. Extending the cabinet drain line may be effective also.

WIRING

All wiring must be in accordance with all governing codes, and with the VAPORMIST® or VAPORMIST DI wiring diagram. The diagram is located inside the removable sub panel cover inside on the right-hand side of the humidifier cabinet.

The use of semiconductor fusing sized per the national electric code is recommended with the SSR option.

ELECTRICAL SPECIFICATIONS AND CAPACITIES/DIMENSIONS

Table 7-1: Electrical Specifications and Capacities

	VM-2	VM-4	VM-6	VM-8	VM-10	VM-12	VM-14	VM-16	VM-21	VM-25	VM-30	VM-34
Output per hour lb/gal/kg	61.7/2.7	121.4/5.4	182.2/8.2	242.9/10.9	303.6/13.6	364.4/16.3	425/19.1	506/22.7	647.7/29.0	759.1/34.0	911.0.9/41.4	1021.2.4/46.2
Operating wt. lbs/kg	82/37	83/38	122/55	122/55	139/63	139/63	139/63	139/63	152/69	152/69	156/71	156/71
Shipping wt. lbs/kg	72/33	73/33	94/43	94/43	98/45	98/45	98/45	98/45	101/46	101/46	105/48	105/48
Amps @ 120v/1ø	16.7	-	-	-	-	-	-	-	-	-	-	-
*208v/1ø/3 wire	9.6	19.2	28.8	38.5	-	-	-	-	-	-	-	-
*230v/1ø***	8.0	16.0	24.0	31.9	39.9	-	-	-	-	-	-	-
*240v/1ø/3 wire	8.3	16.7	25.0	33.3	41.7	-	-	-	-	-	-	-
480v/1ø	4.2	8.3	12.5	16.7	20.8	25.0	29.2	33.3	43.8	-	-	-
600v/1ø	3.3	6.7	10.0	13.3	16.7	20.0	23.3	26.7	35.0	41.7	-	-
*208v/3ø/4 wire	-	16.7**	25.0**	33.3**	29.1**	33.3	38.9	44.4	-	-	-	-
240v/3ø/4 wire	-	14.4**	21.7**	28.9**	25.3**	28.9	33.7	38.5	-	-	-	-
400v/3ø	-	8.7**	13.0**	17.3**	15.2**	17.3	20.2	23.1	30.3	36.1	43.3	-
480v/3ø	-	7.2**	10.8**	14.4**	12.6**	14.4	16.8	19.2	25.3	30.1	36.1	40.9
600v/3ø	-	5.8**	8.7**	11.5**	10.1**	11.5	13.5	15.4	20.2	24.1	28.9	32.7
kW	2	4	6	8	10	12	14	16	21	25	30	34

- * On 208/240 single-phase (3-wire) and 208 3-phase (4-wire) supplies, the neutral line may be utilized for 120 volt when used in conjunction with SDU fan unit. SDU 230v blower needs neutral line with 400v/3ø power.
- ** For wire sizing, the highest leg draw is shown due to current unbalance in some cases. All VAPORMISTs operate at 50/60 Hz.
- *** Output capacity and kW derate of 7%.

Figure 7-1: VAPORMIST® Unit Dimensions

Back view

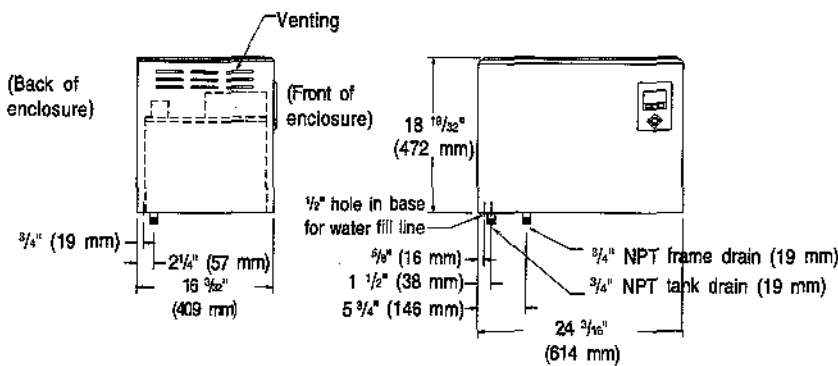

OM-282-3

Bottom view

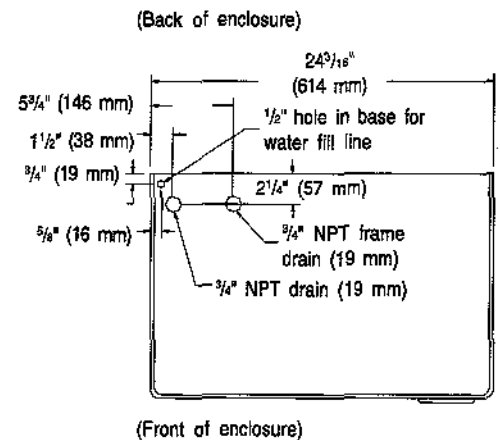

OM-282-2

Top view

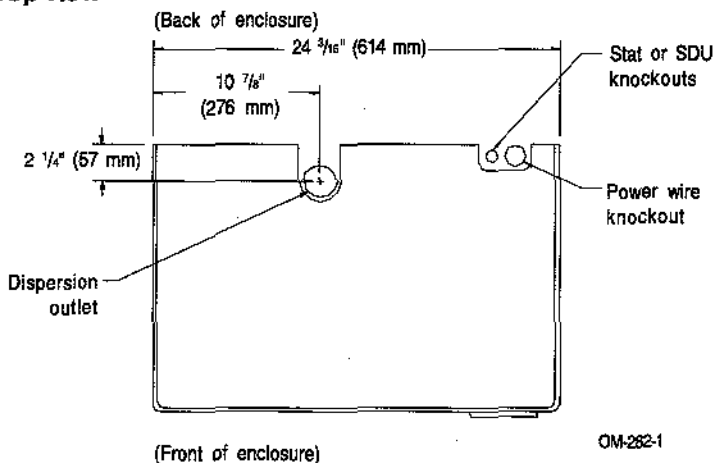

OM-282-1

AREA-TYPE APPLICATION USING SPACE DISTRIBUTION UNITS

The space distribution unit external (SDU-E) converts a VAPORMIST duct humidifier into an area-type humidifier. Instead of the steam dispersion tube being located inside an air duct, the dispersion tube is built into the fan unit. A fan draws in room air and blows it across the dispersion tube, where it disperses the moisture into the room. The SDU-E can be used on all models. The space distribution unit internal (SDU-I) can be used on models VM-2 through VM-10.

Mounting the SDU

The SDU may be mounted on a wall above the VAPORMIST cabinet or mounted on a wall remote from the VAPORMIST. Use the mounting template on the box for correct placement. Two 3/8" lag bolts are provided with each fan unit. (See page 4 for mounting instructions.)

Rise and Throw (SDU-E)

As steam is discharged from the humidifier, it quickly cools and turns to a visible fog that is lighter than air. As this fog is carried away from the humidifier by the airstream, it tends to rise toward the ceiling. If this fog contacts solid surfaces (columns, beams, ceiling, pipes, etc.) before it disappears, it could collect and drip as

water. The greater the space relative humidity, the higher and farther the fog will rise and throw before disappearing. The distances the fog travels before it disappears are given in table 8-1.

Table 8-1 lists the recommended minimum vertical (RISE), horizontal (THROW), and width (SPREAD) clearances for SDU-E area-type humidifiers at 40%, 50% and 60% RH in the space.

The SDU-E contains a 545 cfm blower (120/1/60) and an air flow proving switch field wired to the VAPORMIST humidifier electrical panel. A wiring diagram of the SDU-E is included with the unit.

On a call for humidity, the humidifier will begin producing steam and the start relay will energize the SDU blower. Time-delay is controlled by VAPOR-LOGIC[®] Microprocessor.

Table 8-1: SDU-E Visible Vapor Travel

Humidifier Size	40% RH		50% RH		60% RH	
	Rise* (ft/m)	Throw** (ft/m)	Rise* (ft/m)	Throw** (ft/m)	Rise* (ft/m)	Throw** (ft/m)
VM4	1/31	5/1.6	1.5/46	6.5/2.0	2.5/76	7.5/2.3
VM6	1/31	5/1.6	1.5/46	6.5/2.0	2.5/76	7.5/2.3
VM8	1/31	5.5/1.7	1.5/46	6.5/2.0	2.5/76	7.5/2.3
VM10	1.5/46	6/1.9	2.0/61	7.0/2.2	3.0/92	8.0/2.4
VM12	1.5/46	6/1.9	2.0/61	7.0/2.2	3.0/92	8.0/2.4
VM16	2/61	7/2.2	2.0/61	7.0/2.2	3.0/92	9.0/2.8
VM21	2/61	7.5/2.3	2.5/76	10.0/3.1	3.0/92	12.0/3.7
VM25	2/61	8/2.4	2.5/76	10.5/3.2	3.5/1.1	12.5/3.8
VM30	2/61	8/2.4	2.5/76	10.5/3.2	3.5/1.1	12.5/3.8
VM34	2/61	8/2.4	2.5/76	10.5/3.2	3.5/1.1	12.5/3.8

Table 8-1 Notes:

Table 8-1 states the vertical (rise), horizontal (throw), and width (spread) dimensions that can be expected with the VAPORMIST with SDU-E.

Surfaces cooler than ambient temperature, or objects directly in the path of visible vapor discharge, may cause condensation and dripping.

* Rise: Height visible vapor rises above discharge grill of the SDU-E.

** Throw: Maximum horizontal distance at which condensation occurs.

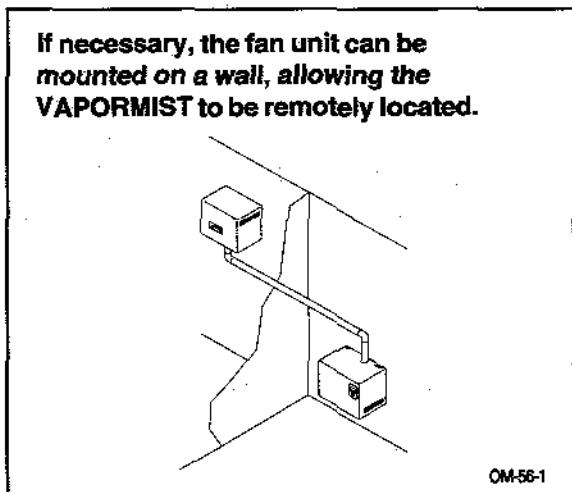
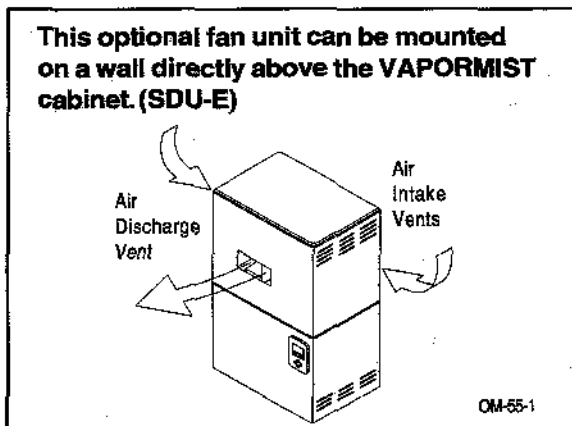

AREA-TYPE APPLICATION USING SPACE DISTRIBUTION UNITS

Figure 9-1: SDU-E Mechanical Detail

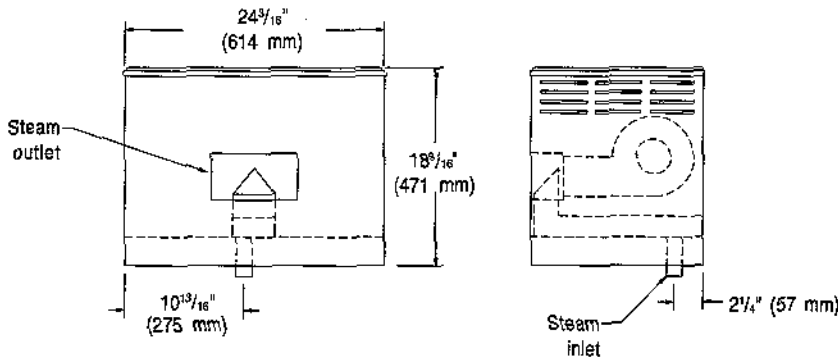

Field wiring is required to connect the SDU fan and air flow proving switch terminals to the respective VAPORMIST electrical panel terminals. Refer to the "external connections diagram" in the O&M package shipped with your unit.

OM-64-1

Instant absorption, no visible vapor

The space distribution unit internal absorption (SDU-I) is available for models VM-2 through VM-10.

Room air is drawn into the unit by a fan, where it is humidified with steam generated by electric heating elements, and then discharged back into the room with no visible vapor trail. Water vapor is instantly absorbed into the air making the VAPORMIST with an internal absorption SDU (SDU-I) ideal for application in finished spaces.

Figure 9-2: SDU-I Mechanical Detail

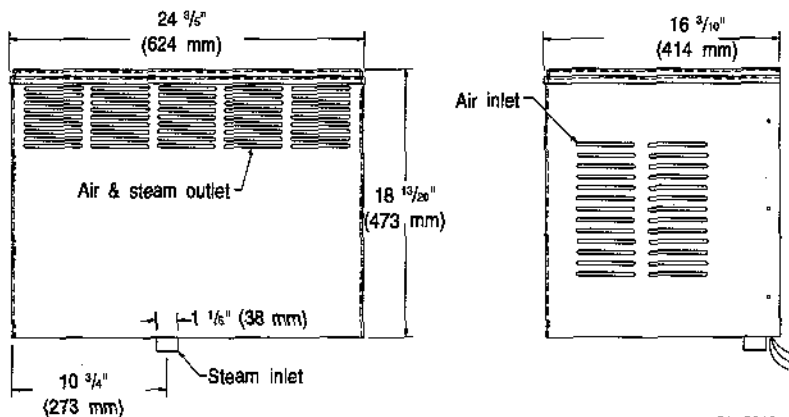

OM-2016

If SDU-E or SDU-I is immediately above the VAPORMIST®, disconnect both hose clamps on steam hose, grip hose and rotate to break it loose from the tubing, then slide the hose up onto the SDU steam tube until sufficient clearance is provided to move the tank.

START-UP AND OPERATION

Introduction

After the system has been properly installed and connected to both electrical and water supplies, it may then be started.

Start-up and Checkout Procedures

Mounting

Check mounting to see that the unit is level and securely supported before filling with water.

Piping

Verify that all piping connections have been completed as recommended and that water pressure is available.

Electrical

Verify that all wiring connections have been made in accordance with all governing codes and the enclosed VAPORMIST® wiring diagram. The external connections diagram will be found with this IOM packet.

Caution: Only qualified electrical personnel should perform start-up procedure.

Figure 10-1: Electronic Probe Control for Maintaining Proper Water Level (VAPORMIST only)

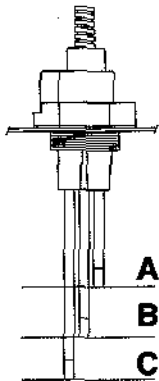

A simple three-probe conductivity sensor cycles a solenoid-operated water fill valve to maintain the proper water levels.

VAPOR-LOGIC₃ Control

The VAPOR-LOGIC₃ is the standard controller for the VAPORMIST. For more information regarding the operation of the VAPOR-LOGIC₃ microprocessor, see the VAPOR-LOGIC₃ *Installation Instructions and Operations Manual*.

Control System Start-Up/Checkout

1. Confirm that proper grounding and an approved earth ground are provided.
2. Confirm that the control signal being connected to the VAPOR-LOGIC₃ system is compatible with the VAPOR-LOGIC₃ program. Identify the VAPOR-LOGIC₃ program code on the wiring diagram. Refer to the VAPOR-LOGIC₃ manual to decipher the code using the nomenclature description on page 8.
3. Confirm all wiring is correct per wiring diagram.
4. Confirm J17, J18 and J19 shunt connectors on VAPOR-LOGIC₃ board are in their correct position per wiring diagram. See page 3 for the physical locations.
5. Confirm that the keypad is mounted on the VAPORMIST with modular cable routed away from high voltage circuits and connected to J2 female connector on control board.
6. Turn on water supply. Confirm drain valve is closed.
7. Turn on power. The keypad will display the introduction of VAPOR-LOGIC₃ and then enter AUTO mode.
8. System will initiate filling of the tank with water. The keypad will display "Filling" as part of the idle screen information.
9. Airflow switch input must be closed.
10. High limit humidistat input must be closed or Variable Air Volume (VAV) control system high limit transmitter must be connected.
11. Sufficient water in the tank, air flow switch closed, high limit humidistat closed, door interlock circuit (optional) closed and a call for humidity will activate the heat output. **If the tank does not contain water and the heat output is activated by the VAPOR-LOGIC₃ control system, a serious failure will result. Immediately remove power from the system and verify that all wiring is done per the wiring instructions in the manual and the unit wiring diagram.**
12. During normal operation, the keypad will display humidifier operating status. See the VAPOR-LOGIC₃ IOM for descriptions to change any of the operating parameters.

VAPORMIST Makeup Water Piping

Use cold or hot make-up water. If the water pressure is above 60 psi and/or water hammer would be objectionable, a pressure-reducing valve or shock arrester should be installed. Even though the VAPORMIST has an internal 1" air gap, some local codes may require a vacuum breaker. **Important:** Minimum water supply pressure is 25 psi.

VAPORMIST DI Makeup Water Piping

In this unit the electronic probe control is replaced by a float valve control.

A float switch provides this device heater protection in the event of a low-water condition and is common to all DI humidifiers. The wiring diagram is located inside the electrical panel cover.

MAINTENANCE

Inspect after first three months of duty. The best way to determine how often your particular system will need maintenance is to remove the cover and inspect it after its first three months of duty. Potable water carries a variety of minerals and other materials in a mix that varies from location to location. This variation in water quality, combined with the hours of operation and duty cycle, will determine your own unique maintenance schedule.

Water quality makes a difference

1. Light to moderately hard water (2 to 10 grains hardness per gallon)
 - annual cleaning
 - regular skimming
2. High mineral content water (more than 10 grains hardness per gallon)
 - cleaning frequency determined by use and water quality
 - regular skimming
 - periodic drain and flush cycles
3. DI/RO water (Model VMDI)
 - no regular cleaning required (although regular inspections are advised)
 - no regular skimming or drain and flush cycles required
 - the presence of chlorides in DI water will eventually cause pitting and failure of the tank and its components
4. To dramatically reduce mineral accumulation inside the evaporating chamber, softening of the makeup water is recommended. (Solids like silica are not removed in the softening process.)

Proper skimming, draining and flushing

1. Skimming will remove most water impurities at the surface, ensuring proper surface tension and an even boil. Skimming will remove most entrained contaminants that have not yet precipitated as scale.
2. Draining and flushing will completely remove entrained contaminants and assist in removing precipitated contaminants like scale and silica.

To inspect and service

1. Remove the evaporating chamber
 - Remove the two fasteners on each side of the cover enclosure.
 - Remove the enclosure.
 - **Do not remove the electrical panel cover or heater terminal cover until electrical power is disconnected. Safety first.**
 - If the VAPORMIST has an SDU mounted directly above it, the SDU cover must be removed before removing the unit cover.

- If the tank is hot, cool it down by moving the valve lever located on the back of the drain valve to the manual open position – the fill valve will eventually open allowing cool water to run through the tank until it is cool enough to handle.
 - Shut off the water supply.
 - Shut off the electrical supply.
 - Allow the tank to completely drain.
 - Disconnect the fill line at the supply side of the fill valve.
 - Disconnect the electrical plugs between the tank components and the back of the electrical panel (includes: power plug, fill plug, drain plug, water level control plug, tank temperature sensor plug and thermal trip plug). **DISCONNECT BY PULLING ON PLUG HOUSING. DO NOT DISCONNECT BY PULLING ON CORD OR WIRES.**
 - Disconnect the drain union on the back left corner of the frame.
 - Disconnect the steam supply hose from the top of the tank.
 - Lift the tank foot above the frame flange and slide the tank assembly forward to remove.
2. Loosen the four cover bolts and remove the cover assembly from the tank.
 3. Clean the tank interior using a putty knife or similar flat instrument.
 4. Unscrew the probe rod assembly and clean the probe cup, ensuring that all passageways are clear. Clean the probe rods using steel wool or a similar mild abrasive material. Inspect the composite plastic probe rod holder for any signs of cracking, roughness, or deterioration. If found, replace.
 5. Install the probe and probe plug assembly. Verify ground wire.
 6. Secure the chamber cover, making sure the cover gasket is seated and the chamber is sealed.
 7. Re-install the evaporating chamber.
 - Reconnect the fill line.
 - Reconnect the electrical plugs.
 - Reconnect the drain union.
 - Reconnect the vapor hose.
 8. Move the drain valve lever back to the auto position.
 9. Turn on the water supply. Turn on the electrical power.

MAINTENANCE

Off Season Shut-Down

1. Switch off electrical power.
2. Remove enclosure.
3. Shut off water supply to make-up valve.
4. Drain evaporation chamber, and clean if necessary (see "Cleaning the Evaporating Chamber" above).
5. Replace enclosure.
6. Leave chamber dry, the power "OFF," and the water shutoff valve closed until the next humidification season.
2. Loosen the four cover bolts and remove the cover assembly from the tank.
3. Inspect the tank interior for debris or pitting.
4. Inspect the valve inlet for debris.
5. Check the operation of the float valve and the condition of the float seat.
6. Check the low water switch for free operation.
7. Secure the chamber cover making sure the cover gasket is seated and the chamber is sealed.

VAPORMIST DI

The VAPORMIST DI unit uses DI/RO water. Because these water types are mineral-free, cleaning of the evaporator chamber should not be necessary. However, there are some simple maintenance steps that should be followed to ensure all parts of the unit are in working order.

To inspect and service

1. Remove the evaporating chamber.
 - Remove the two fasteners on each side of the cover enclosure.
 - Remove the enclosure.
 - **Do not remove the electrical panel cover or heater terminal cover until electrical power is disconnected. Safety first.**
 - If the VAPORMIST has an space distribution unit (SDU) mounted directly above it, the SDU cover must be removed before removing the unit cover.
 - If the tank is hot, cool it down by opening the manual ball valve on the side of the tank. The float valve will open allowing cool water to run into the tank until it is cool enough to handle.
 - Shut off the water supply.
 - Shut off the electrical supply.
 - Allow the tank to drain completely.
 - Disconnect the fill line at the fill fitting.
 - Disconnect the electrical plugs between the tank components and the back of the electrical panel (includes: power plug, low water switch plug, tank temperature sensor plug and thermal trip plug).
DISCONNECT BY PULLING ON PLUG HOUSING. DO NOT DISCONNECT BY PULLING ON CORD OR WIRES.
 - Disconnect the drain union on the back left corner of the frame.
 - Disconnect the steam supply hose from the top of the tank.
 - Lift the tank foot above the frame flange and slide the tank assembly forward to remove.

8. Reinstall the evaporating chamber.
 - Reconnect the fill line.
 - Reconnect electrical plugs.
 - Reconnect drain union.
 - Reconnect vapor hose.
9. Close the drain valve.
10. Turn on the water supply. Turn on the electrical power.

Off-Season Shut-Down Procedure

1. Switch off electric power.
2. Remove enclosure.
3. Shut off water supply to make-up valve.
4. Drain evaporating chamber by opening the drain valve. For units with end-of-season drain, please refer to VAPOR-LOGIC[®] IOM.
5. Replace enclosure.
6. Leave chamber dry, power off, and water shut off valve closed until the next humidification season.

VAPORMIST® TROUBLE-SHOOTING GUIDE

PROBLEM	POSSIBLE CAUSE	RECOMMENDED ACTION
Humidifier does not heat.	Incorrect or non-existent supply voltage to unit	Check main line safety switch . Check main line fuses. Check for proper supply voltage.
	Incorrect or non-existent control voltage	Reset control transformer circuit breaker. Check for 24 VAC control circuit voltage at T-1 and T-2 on the control board.
	Humidistat not calling	Set humidistat to call. Inspect for faulty humidistat.
	Safety controls open.	Check safety controls, air flow switch, and high limit humidistat.
Humidifier will not fill.	No water pressure at valve	Check water supply/shut off valves.
	Faulty water fill valve	Check for 24 volts at the fill valve.
	Plugged strainer	Check strainer.
	Plugged valve	Check valve.
	Faulty control board	Verify control voltage across the fill valve output.
Humidifier does not stop filling.	Lack of tank to probes' electrical continuity; water conductivity 100 micromhos/cm (2 gr/gal) min.	Add salt to the tank. If this solves the problem, consult factory for further advice.
	Fill valve stuck open	Check valve for foreign matter.
	Drain valve not closed Fill valve installed backward	Check for correct water flow, through valve, note arrow.
	Auto-drain mode	Humidifier may be in periodic drain and flush. Check controller display.
Low output	Electric drain valve not seating	Correct cause of leakage or replace valve.
	Fill valve stuck open	Check valve for foreign matter.
Unit short cycles	Controller cycle rate set to low	Review controller cycle set point.
Reduced or no output even though water is at the proper level.	Heater malfunctioning	Verify that proper voltage is being applied to heaters. Check heater amp draw and compare to wiring diagram ratings.
	Malfunctioning control system	Heater contactor not functioning, replace. Service fuses blown. Auxiliary limit controls not allowing system to operate (dust humidistat, air flow proving switch, etc.) Reset, replace or calibrate as required. Faulty or inaccurate humidistat, replace or calibrate.

*Probe rod corrosion or probe head material aging may cause level control system failure. This generally does not occur in the first two years of operation.

VAPORMIST® DI TROUBLE-SHOOTING GUIDE

PROBLEM	POSSIBLE CAUSE	RECOMMENDED ACTION
Humidifier will not heat.	Control transformer	Reset control transformer circuit breaker.
	Humidistat is not calling	Set humidistat to call. Inspect for faulty humidistat.
	Safety controls open	Check safety controls, air flow switch, high limit humidistat, etc.
	Low water cutoff	Check at board 32 and 33. Measure 0 volts for closed switch, approximately 2.5 volt for A.C. open switch.
Humidifier will not fill.	No water pressure at valve	Check manual water supply. Valve, minimum 25 psi water pressure.
	Malfunctioning float switch	Check to make sure that float moves freely on stem.
	Plugged fill valve	Check fill valve inlet.
Humidifier does not stop filling.	Open drain valve	Obstruction in drain valve will not allow complete closure. Clean or replace valve.
	Manual drain valve not closed	Close drain valve.
	Fill valve stuck open	Check valve for foreign matter, water-logged float, broken float arm, or worn valve stopper.
Reduced or no output even though water is at the proper level.	Heater malfunctioning	Verify that proper voltage is being applied to heaters. Check heater (amp draw and compare to wiring diagram ratings).
	Malfunctioning control system	Heater contactor not functioning, replace. Service fuses blown. Auxiliary limit controls not allowing system to operate (dust humidistat, air flow proving switch, etc.) Reset, replace or calibrate as required. Faulty or inaccurate humidistat, replace or calibrate.

REPLACEMENT PARTS

Table 15-1: Space Distribution Unit (SDU-E)

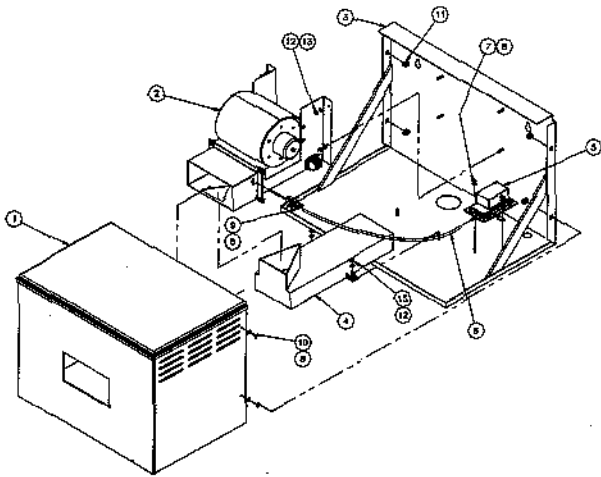

sduextassy-om

No.	Description	Qty.	Part No.
1	Cabinet base, SDU-E	1	330000-003
2	Blower, SDU99 external assembly	1	409540-003
3	Frame, SDU external	1	165542
4	Dispersion chamber, SDU99 w/1 1/2" out	1*	160445-001
4	Dispersion chamber, SDU99 w/2" out	1*	160445-002
5	Switch, air flow	1	406190
6	Tubing, 1/4" PVC plastic tubing	1	405722
7	Nut, 8-32 x 3/8"	2	700200-002
8	Star washer, 8-32	6	700200-003
9	Screw, self tapping 8-32 x 3/8"	4	700000-005
10	Screw, 8-32 x 1/2 panhead Phillips F	4	700170-007
11	Cage clip, 8-32	4	409593-001
12	Nut, 1/4-20 Hex	10	700300-016

* Specify model size when ordering.

Table 15-2: VAPORMIST® Subpanel with SDU-E

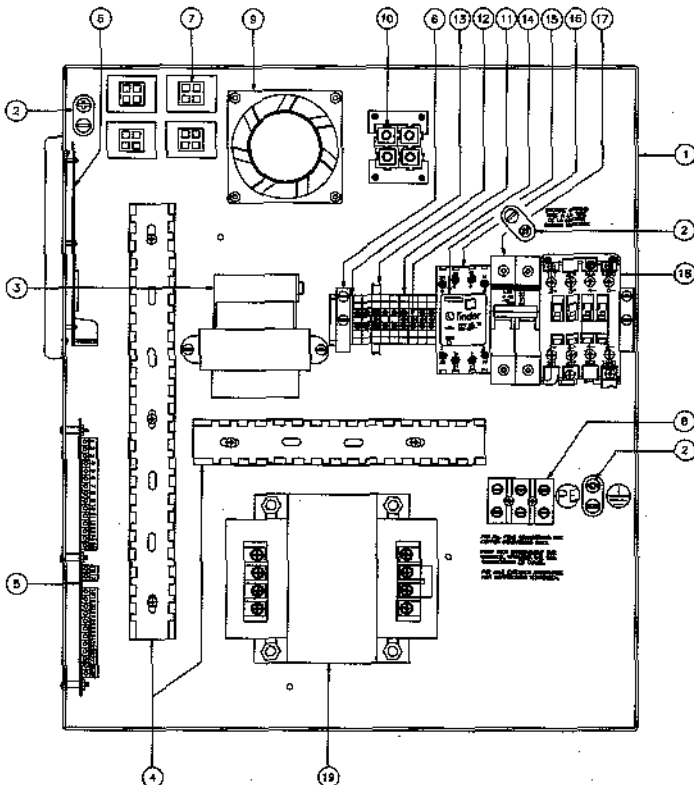

om-213-3

No.	Description	Qty.	Part No.
1	Subpanel, VM99 barrier	1	120801
2	Ground lug, L-35 10-14 GA CP-8	1	409250-017
2	Ground lug, L-70 6-8 GA CP-4	1	409250-018
3	Transformer 600V	1	408986
3	Transformer 120/240/480/208	1	408965-001
4	Channel, wire with cover	2	408999-003
5	Main board, VL-3	1	408490-001
6	Keypad board, VL-3	1	408490-002
7	Plug, 4 prong female	4	409585-008
8	3 Pole 3ø, power block	1	408300-002
8	2 Pole 1ø, power block	1	408300-001
9	Fan, 24 volt	1	408677-001
10	Power plug	4	409585-001
11	Terminal	8	408252-001
12	Terminal, ground	1	408252-010
13	Terminal, end plate	1	408252-005
14	Terminal, jumper	2	408252-008
15	Relay finders	1	407900-006
16	Relay finders, base	1	407900-007
17	Breaker, 2 pole 1.5A 480V	2	406775-001
17	Breaker, 2 pole 1.5A 600V	1	406775-003
18	Contactors, 60A	1	407001-021
18	Contactors, 32A	1	407001-020
19	Transformer, 480V 300VA	1	408991
19	Transformer, 575V 300VA	1	408992
19	Transformer, 480V 500VA	1	408996-008
19	Transformer, 600V 500VA	1	408996-009

REPLACEMENT PARTS

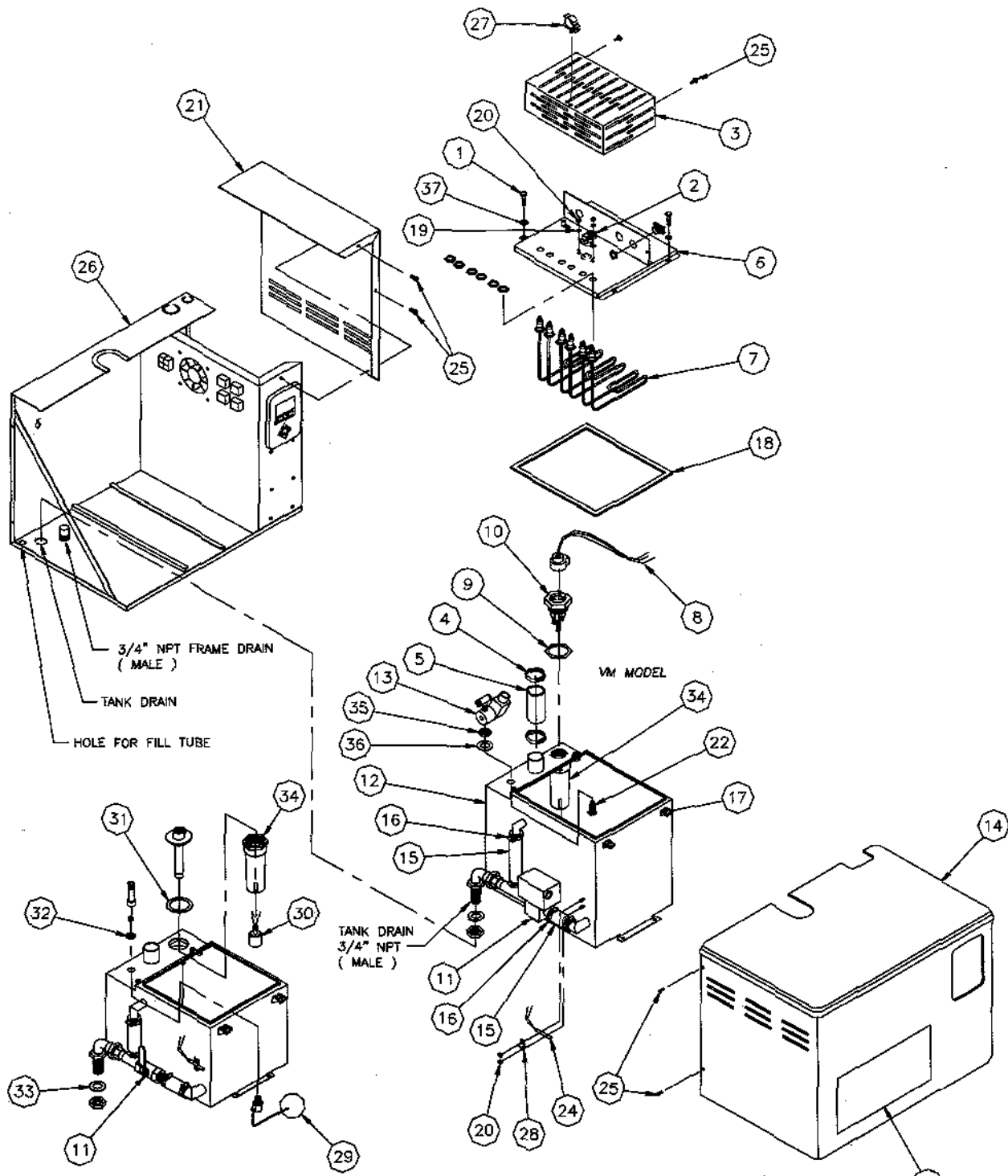

REPLACEMENT PARTS

Table 17-1: VAPORMIST® (see drawing on page 16)

No.	Description	Qty.	Part No.
1	Head bolt, large Phillips, ¼ - 20 X 1"	4	700300-013
2	Thermo cut-out	1	409560-001
3	Cover, heater terminal	1	*
4	Hose clamp, 2"	2	700560-200
5	Hose cuff, 1½"	1	305390-006
5	Hose cuff, 2"	1	305391-006
6	Cover, tank	1	*
7	Heater element	*	*
8	Probe assembly with cord and plug	1	406050-005
9	Probe assembly gasket	1	309750-004
10	Probe assembly, VM 2-4	1	406270
10	Probe assembly, VM 6-34	1	406275
11	Valve, ¾" electric, 24V	1	505400-001
11	Valve, ½" SST ball	1	505000-003
11	Drain, ¼" NPT E.O.S., 24V solenoid SST w/DIN plug (not shown)	1	505086-003
12	Tank weldment	1	*
13	Valve, ¼" solenoid, 24V w/DIN plug	1	505084-001
14	Cabinet enclosure	1	330000-001
15	Hose, ¾" ID	1	307020-002
16	Hose clamp, ¾"	4	700560-075

* Specify humidifier model and serial numbers when ordering.

REPLACEMENT PARTS

Table 17-1 continued: VAPORMIST® (see drawing on page 16)

No.	Description	Qty.	Part No.
17	Nut assembly, ¼-20, VM/VMDI 2-4	4	700650
17	Nut assembly, ¼-20, VM/VMDI 6-34	2	700650
18	Cover, tank gasket	1	*
19	Washer, #8 external tooth, pltd	2	700200-003
20	Nut, #8-32 hex, pltd	6	700200-002
21	Cover, subpanel	1	120277
22	Fill adapter, VM 2-4	1	160226-041
22	Fill adapter, VM 6-16	1	160224-041
22	Fill adapter, VM 21-34	1	160224-052
23	Panel, insulation	1	309845-003
24	Sensor, temperature	1	405760
25	Screw, Phillips head, #8-32 X ½"	8	700170-007
26	Frame assembly, chassis	1	165541
27	Clip, wire harness	1	405892-001
28	Clip, temperature sensor	1	408251
29	Valve assembly, float	1	505310
30	Switch, float, 1/8" NPT	1	408420-002
31	Gasket, 2.50 OD X 1.90 ID	1	309750-004
32	Ring, seal, ¼"-18 NPT	1	306365
33	Gasket, bulkhead, 1.60 OD X 1.15 ID	1	309750-005
34	Probe housing, nylon, VM	1	308500
35	Nut, VM heater .475	1	409601-001
35	Nut, VM heater .375	1	409602-001
36	Gasket, VM heater .475	1	409601-002
36	Gasket, VM heater .375	1	409602-002

* Specify humidifier model and serial numbers when ordering.

REPLACEMENT PARTS

Table 19-1: VAPORMIST® subpanel with SSR

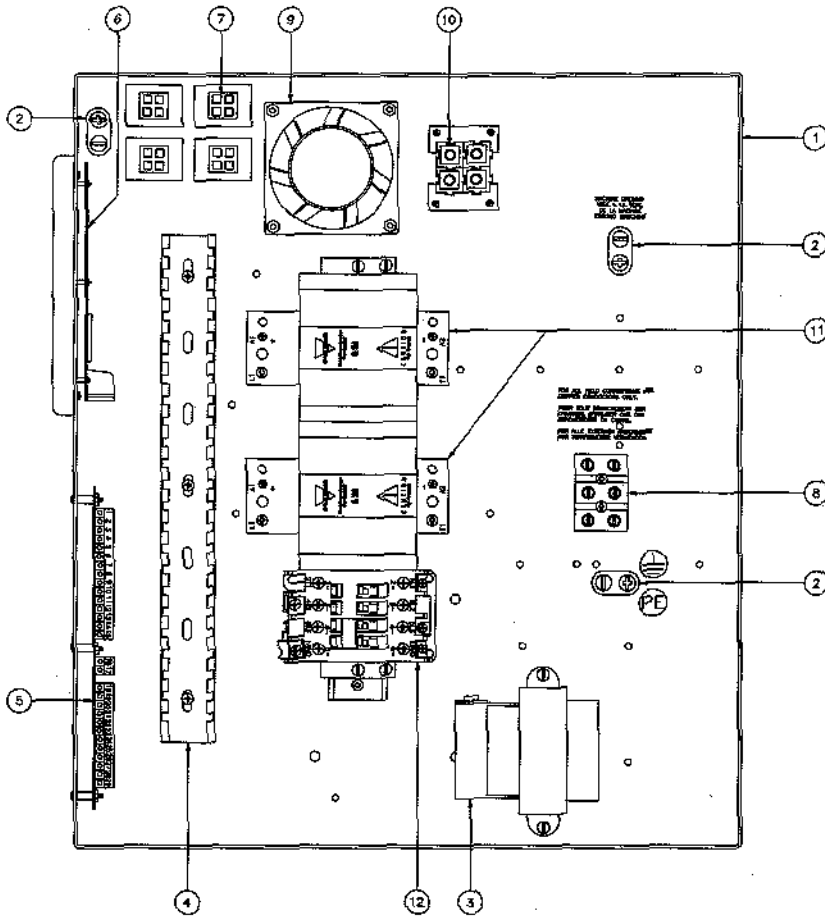

No.	Description	Qty.	Part No.
1	Subpanel, VM99 barrier	1	120801
2	Ground lug, L-35 10-14 GA CP-8	1	409250-017
2	Ground lug, L-70 6-8 GA CP-4	1	409250-018
3	Transformer 600V	1	408986
3	Transformer 120/208/240/480	1	408965-001
4	Channel, wire with cover	2	408999-003
5	Main board, VL-3	1	408490-001
6	Keypad board, VL-3	1	408490-002
7	Plug, 4 prong female	4	409585-008
8	3 Pole 3ø, power block	1	408300-002
8	2 Pole 1ø, power block	1	408300-001
9	Fan, 24 volt	1	408677-001
10	Power plug, 4	4	409585-001
11	SSR, 480 VAC 50 AMP 1 Pole	2	408677-002
12	Contactors, 60A	1	407001-021
12	Contactors, 32A	1	407001-020

TWO-YEAR LIMITED WARRANTY

DRI-STEEM Humidifier Company ("DRI-STEEM") warrants to the original user that its products will be free from defects in materials and workmanship for a period of two (2) years after installation or twenty-seven (27) months from the date DRI-STEEM ships such product, whichever date is the earlier.

If any DRI-STEEM product is found to be defective in material or workmanship during the applicable warranty period, DRI-STEEM's entire liability, and the purchaser's sole and exclusive remedy, shall be the repair or replacement of the defective product, or the refund of the purchase price, at DRI-STEEM's election. DRI-STEEM shall not be liable for any costs or expenses, whether direct or indirect, associated with the installation, removal or re-installation of any defective product.

DRI-STEEM's limited warranty shall not be effective or actionable unless there is compliance with all installation and operating instructions furnished by DRI-STEEM, or if the products have been modified or altered without the written consent of DRI-STEEM, or if such products have been subject to accident, misuse, mishandling, tampering, negligence or improper maintenance. Any warranty claim must be submitted to DRI-STEEM in writing within the stated warranty period.

DRI-STEEM's limited warranty is made in lieu of, and DRI-STEEM disclaims all other warranties, whether express or implied, including but not limited to any IMPLIED WARRANTY OF MERCHANTABILITY, ANY IMPLIED WARRANTY OF FITNESS FOR A PARTICULAR PURPOSE, any implied warranty arising out of a course of dealing or of performance, custom or usage of trade.

DRI-STEEM SHALL NOT, UNDER ANY CIRCUMSTANCES BE LIABLE FOR ANY DIRECT, INDIRECT, INCIDENTAL, SPECIAL OR CONSEQUENTIAL DAMAGES (INCLUDING, BUT NOT LIMITED TO, LOSS OF PROFITS, REVENUE OR BUSINESS) OR DAMAGE OR INJURY TO PERSONS OR PROPERTY IN ANY WAY RELATED TO THE MANUFACTURE OR THE USE OF ITS PRODUCTS. The exclusion applies regardless of whether such damages are sought based on breach of warranty, breach of contract, negligence, strict liability in tort, or any other legal theory, even if DRI-STEEM has notice of the possibility of such damages.

By purchasing DRI-STEEM's products, the purchaser agrees to the terms and conditions of this limited warranty.

DRI-STEEM[®]
HUMIDIFIER COMPANY



14949 Technology Drive • Eden Prairie, MN 55344
Phone: (800)328-4447 • (612)949-2415 • Fax: (612)949-2933
E-Mail: sales@dristeem.com • Web: www.dristeem.com

Europe Office:

Bell Place, Bell Lane • Syresham, Brackley • NN13 5HP, U.K.
Phone: +44 1280 850122 • Fax: +44 1280 850124
E-Mail: 106277.1443@compuserve.com



Printed on recycled paper. Minimum
10% Post Consumer Waste.

Continuous product improvement is a policy of DRI-STEEM Humidifier Company therefore, product features and specifications are subject to change without notice.

DRI-STEEM, RAPID-SORB, VAPORMIST, VAPOR-LOGIC, are Registered Trademarks of the DRI-STEEM Humidifier Company.
TEFLON is a Registered Trademark of Dupont.