

READ AND SAVE THESE INSTRUCTIONS



WATER TREATMENT





200 series
reverse-osmosis systems

Installation, Operation,
and Maintenance Manual





Warnings and cautions

 <p>WARNING</p> <p>Indicates a hazardous situation that could result in death or serious injury if instructions are not followed.</p>	<p>CAUTION</p> <p>Indicates a hazardous situation that could result in damage to or destruction of property if instructions are not followed.</p>
---	--

mc_051508_1145

 <p>WARNING</p>	<p>Attention installer</p> <p> Read this manual before installing, and leave this manual with product owner. This product must be installed by qualified HVAC and electrical contractors and in compliance with local, state, federal, and governing codes. Improper installation can cause property damage, severe personal injury, or death as a result of electric shock, burns, or fire.</p> <p>DriSteem Technical Support: 800-328-4447</p> <p>Read all warnings and instructions</p> <p>Read this manual before performing service or maintenance procedures on any part of the system. Failure to follow all warnings and instructions could produce the hazardous situations described, resulting in property damage, personal injury, or death.</p> <p>Failure to follow the instructions in this manual can cause moisture to accumulate, which can cause bacteria and mold growth or dripping water into building spaces. Dripping water can cause property damage; bacteria and mold growth can cause illness.</p> <p>If the IOM is missing, go to www.dristeem.com to download a replacement.</p>
 	<p>Shut down the energy source</p> <p>Before performing service or maintenance procedures on any part of the system, verify that all energy sources are off. Failure to shut down the energy source could result in fire, explosion, electrical shock, and other hazardous conditions. These hazardous conditions could cause property damage, personal injury, or death.</p> <p>Contact with energized circuits can cause property damage, severe personal injury or death as a result of electrical shock or fire. Do not remove electrical panel cover/door or access panels until electrical power is disconnected.</p> <p>Follow the shutdown procedure in the system IOM before performing service or maintenance procedures on any part of the system.</p>

Warnings and cautions

 WARNING	
 	<p>Disconnect electrical power Disconnect electrical power before installing supply wiring or performing service or maintenance procedures on any part of the humidification system. Failure to disconnect electrical power could result in fire, electrical shock, and other hazardous conditions. These hazardous conditions could cause property damage, personal injury, or death.</p> <p>Contact with energized circuits can cause property damage, severe personal injury, or death as a result of electrical shock or fire. Do not remove RO system electrical panel cover, heater terminal cover, or subpanel access panels until electrical power is disconnected.</p> <p>Follow the shutdown procedure in this manual before performing service or maintenance procedures on any part of the system.</p> <p>mc_052410_1510</p>
	<p>Electric shock hazard If the RO system starts up responding to a call for humidity during maintenance, severe bodily injury or death from electric shock could occur. To prevent such start-up, follow the procedure below before performing service or maintenance procedures on this RO system (after the tank has cooled down and drained):</p> <ol style="list-style-type: none">1. Use Vapor-logic® keypad/display to change control mode to Standby.2. Shut off all electrical power to the RO system using field-installed fused disconnect, and lock all power disconnect switches in OFF position.3. Close field-installed manual water supply shut-off valve. <p>mc_050808_1540</p>

Fill in the following information for your records

Date of purchase _____

Customer's name _____

Model number _____

Serial number _____

Table of contents

WARNINGS AND CAUTIONS	ii
OVERVIEW	2
System specifications	2
Controller	4
RO supply water requirements	5
Flow schematic	6
Component identification	8
INSTALLATION	9
OPERATION	11
System operation	11
Initial system start-up	11
System flush	11
Normal operations	11
Shutdown	11
Start-up checklist	12
Start-up	13
Start-up procedure	13
Test operation	13
Initial system start-up	13
Operating do's and don't's	14
Do	14
Don't	14
Vapor-logic keypad/display	15
Changing mode	16
Controller display activity definitions	16
Test outputs	16
Test run	16
Status screen	17
Diagnostics and Alarms	18
Modbus, BACnet, LonTalk interoperability	19

Table of contents

MAINTENANCE	21
Maintenance information	21
Maintenance tips	21
When to change sediment and carbon filters	21
Changing cartridge filters	21
When to clean or replace membranes	22
Replacing membranes	22
Tools	22
Procedure	22
Membrane cleaning in the RO system	23
How does it work?	23
Scale cleaning cartridge	23
Cleaning procedure	23
Organic cleaning cartridge	24
Cleaning procedure	24
Storage	25
Membrane preservative cartridge	25
Preserving procedure	25
Flushing out preservative/restart procedure	25
System monitoring and record keeping	26
System operating log	27
Water quality test strips	28
Water Quality Test Strips Sample Pack	28
REPLACEMENT PARTS	29
RO system (Models 201, 202, and 203)	29
Subpanel	31
WARRANTY	32

ATTENTION INSTALLER

Read this manual before installing.
Leave manual with product owner.

DriSteem® Technical Support
800-328-4447

Where to find more information

Our website:

The following documents are available on our web site: www.dristeem.com

- Water Treatment Systems Catalog
- Vapor-logic Controller Installation and Operation Manual

DriCalc® sizing and selection software:

DriCalc, our software for system sizing and selection, can be ordered at our web site.

Call us at 800-328-4447

Obtaining documents from our web site or from DriCalc is the quickest way to view our literature, or we will be happy to mail literature to you.

Keypad/display and troubleshooting

The *Vapor-logic Installation and Operation Manual*, which was shipped with your RO system, is a comprehensive operation manual. Refer to it for information about using the keypad/display and Web interface, and for troubleshooting information.

Download DriSteem literature

Most DriSteem product manuals are available our website: www.dristeem.com

System specifications

Table 2-1:
RO station electrical specifications and weights

Model	Hz	Motor HP	Volts*/Amps	Phase/Frequency	Approximate shipping weight**	Operating weight**	Noise***
201	60	1/3	110-120 VAC/5.5A (208-240 VAC/2.8A)	1/60Hz	132 lbs. (60 kg)	156 lbs. (71 kg)	49 dBA min. 58 dBA max.
202					137 lbs. (62 kg)	162 lbs. (73 kg)	
203					143 lbs. (65 kg)	168 lbs. (76 kg)	

* 115V or 230V must be ordered specifically
 ** Tank bladder pressure = 28 psi, tank full at 50 psi
 *** Noise measurements taken 6.5' (2 m) in front of the RO-200 water treatment system.

NOTES:

- All systems rated at 50°F (10°C) using 1000 ppm sodium chloride (NaCl) solution. System capacity decreases significantly with decrease in feed water temperature.
- Chlorine requirements for the feed water are:
 - Thin-Film (standard) 0 ppm
- Feed water must be filtered to a turbidity of less than 1 NTU.
- System recovery (permeate to concentrate ratio) must be maintained at the recommended level. A higher than recommended recovery will lead to a premature fouling of the membrane with a loss of permeate flow and permeate quality.
- Recommended minimum clearances if:
 - 24" or greater (610 mm) above: 6" (152 mm) left, right and rear and 24" (610 mm) front
 - less than 24" (610 mm) above: 6" (152 mm) left and right and 24" (610 mm) front and rear

System specifications

Table 3-1: RO station capacities			
Model	201	202	203
Rated capacity, permeate			
Gallons/minute	0.2	0.4	0.6
Concentrate flow (reject) ¹			
Gallons/minute	0.6 - 1.1	0.7 - 1.2	0.5 - 1.0
Recirc flow (adjustable as needed) ^{1,2}			
Gallons/minute	0 - 0.5	0 - 0.5	0 - 0.5
System pressure, psi (pump pressure through membranes)	100 - 150	100 - 150	100 - 150
°F (°C)	50 (10)	50 (10)	50 (10)
Pre-filters			
Sediment cartridge - 5 micron	1	1	1
Carbon cartridge - 10 micron	1	1	1
Pressure switch settings			
Low pressure (for pump protection)	8 psi	8 psi	8 psi

¹. Reduce concentrate flow by the amount of recirc flow used to maintain the recommended maximum system level.

². Recirc flow usage will reduce water but may decrease membrane life.

Product overview

CONTROLLER

The Vapor-logic controller in the RO system provides menus for all RO system functions, with a Web interface for Ethernet access (see Figure 4-1).

The Vapor-logic Installation and Operation Manual ships with the RO system. Refer to it for information on using the keypad/display and Web interface, and for troubleshooting information.

Static IP addresses

See the Vapor-logic Controller Installation and Operation Manual shipped with the RO system for more information about configuring IP addresses.

FIGURE 4-1: VAPOR-LOGIC KEYPAD/DISPLAY AND WEB INTERFACE

KEYPAD/DISPLAY

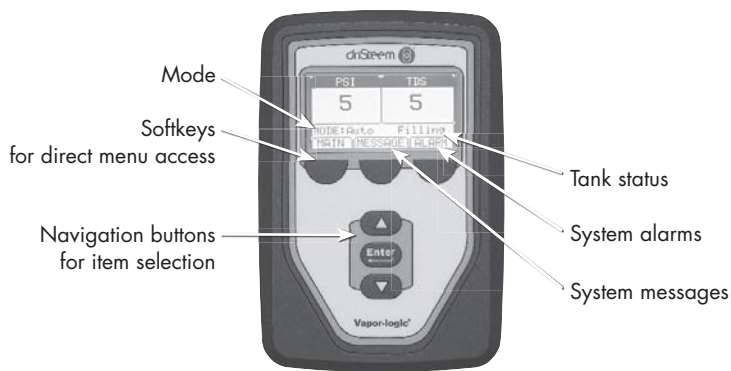

Product overview

WEB INTERFACE

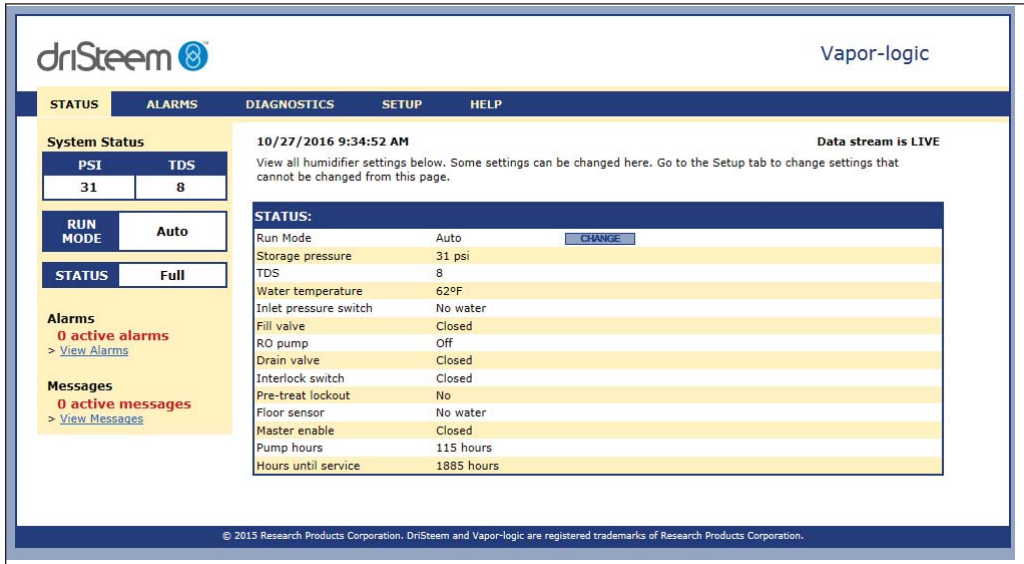

RO SUPPLY WATER REQUIREMENTS

Supply water quality is an important component of DriSteem reverse osmosis system reliability and maintenance.

Water hardness can increase the reverse osmosis system maintenance requirements.

To maximize service life and minimize maintenance for RO systems and downstream equipment, softened water is required with all DriSteem RO systems.

Flow schematic

FIGURE 6-1: FLOW SCHEMATIC

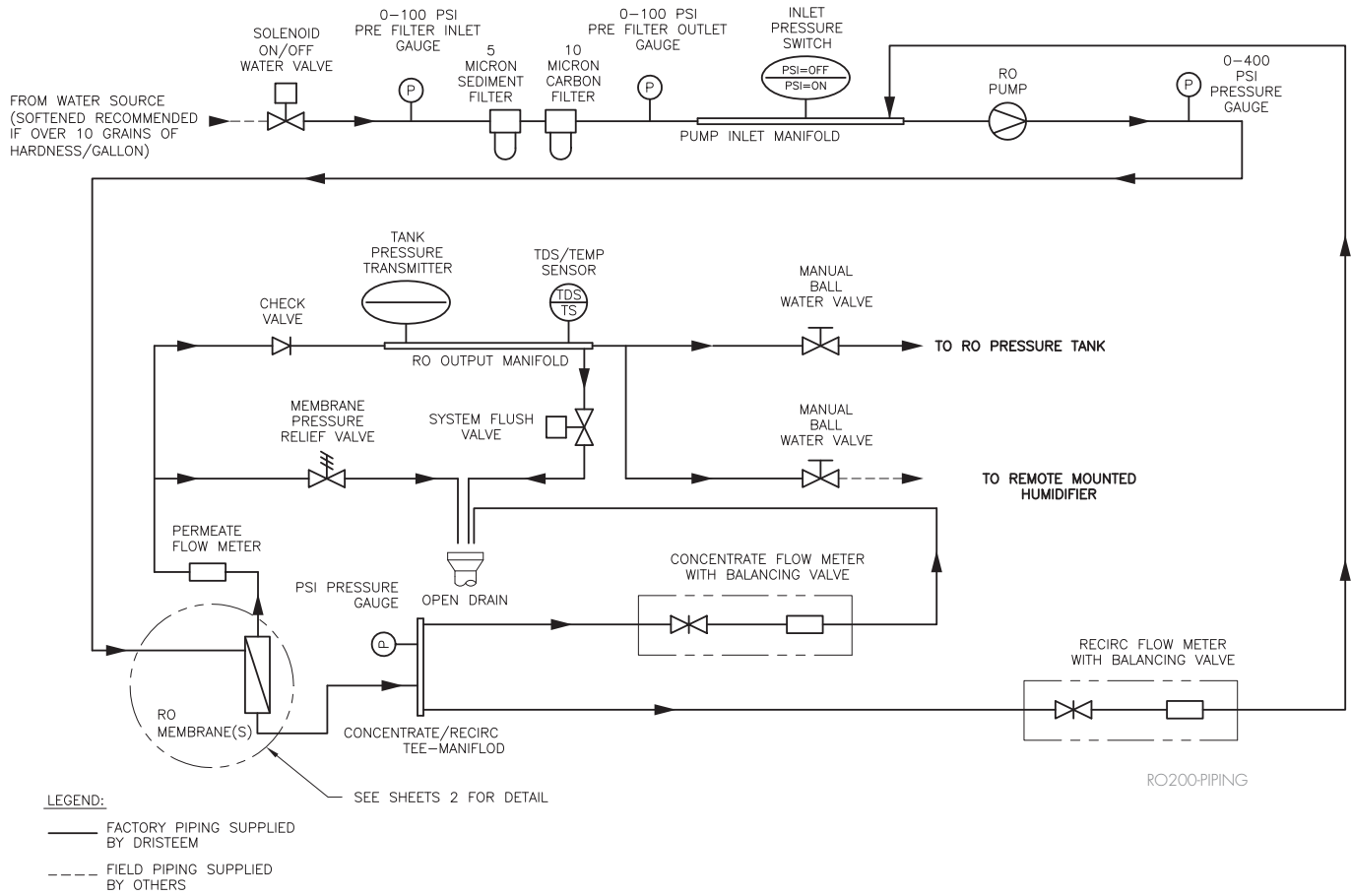

Flow schematic

FIGURE 7-1: FLOW SCHEMATIC

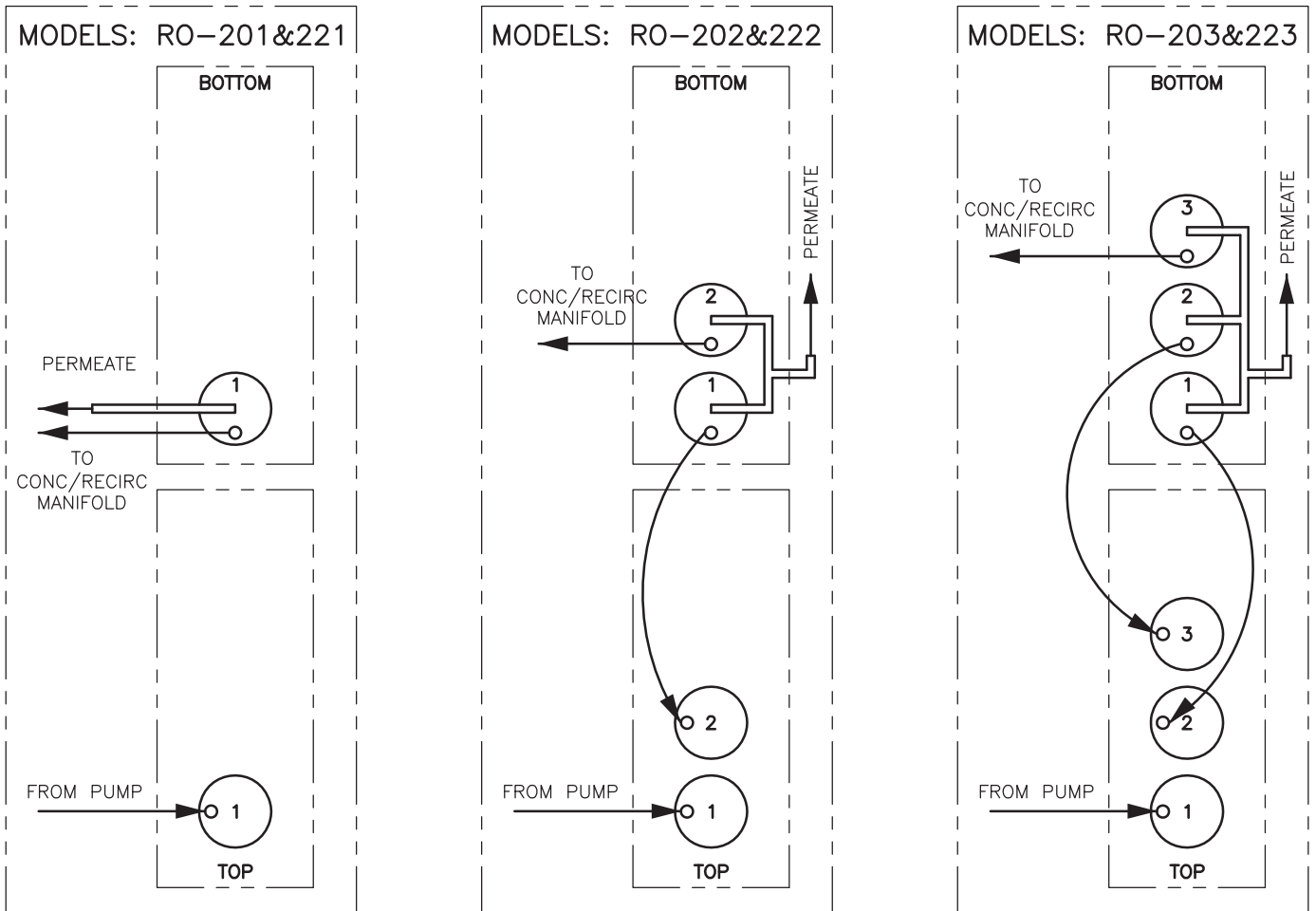

LEGEND:

- FACTORY SUPPLY/CONDENSATE PIPING
- ▬ FACTORY PERMEATE PIPING

RO200-PIPING-1

Component identification

FIGURE 8-1: COMPONENT IDENTIFICATION

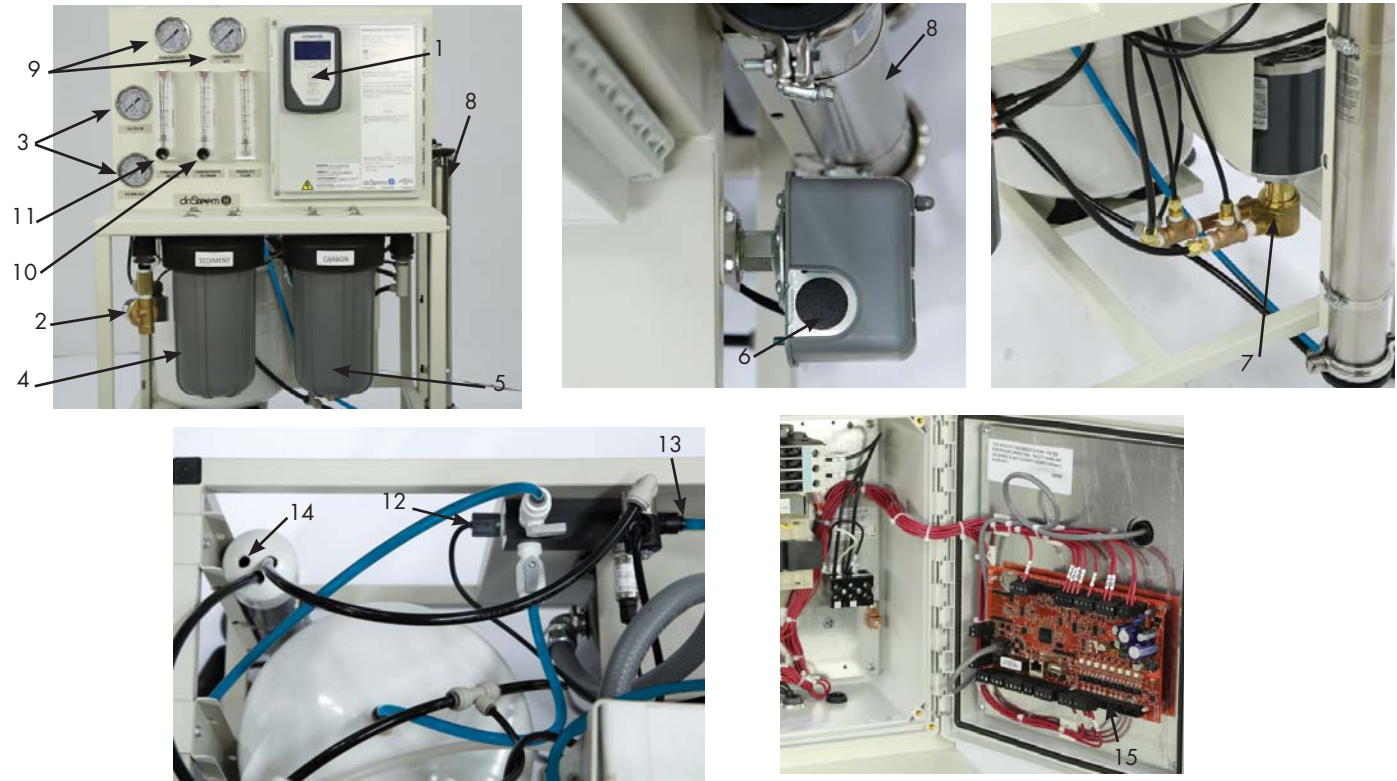
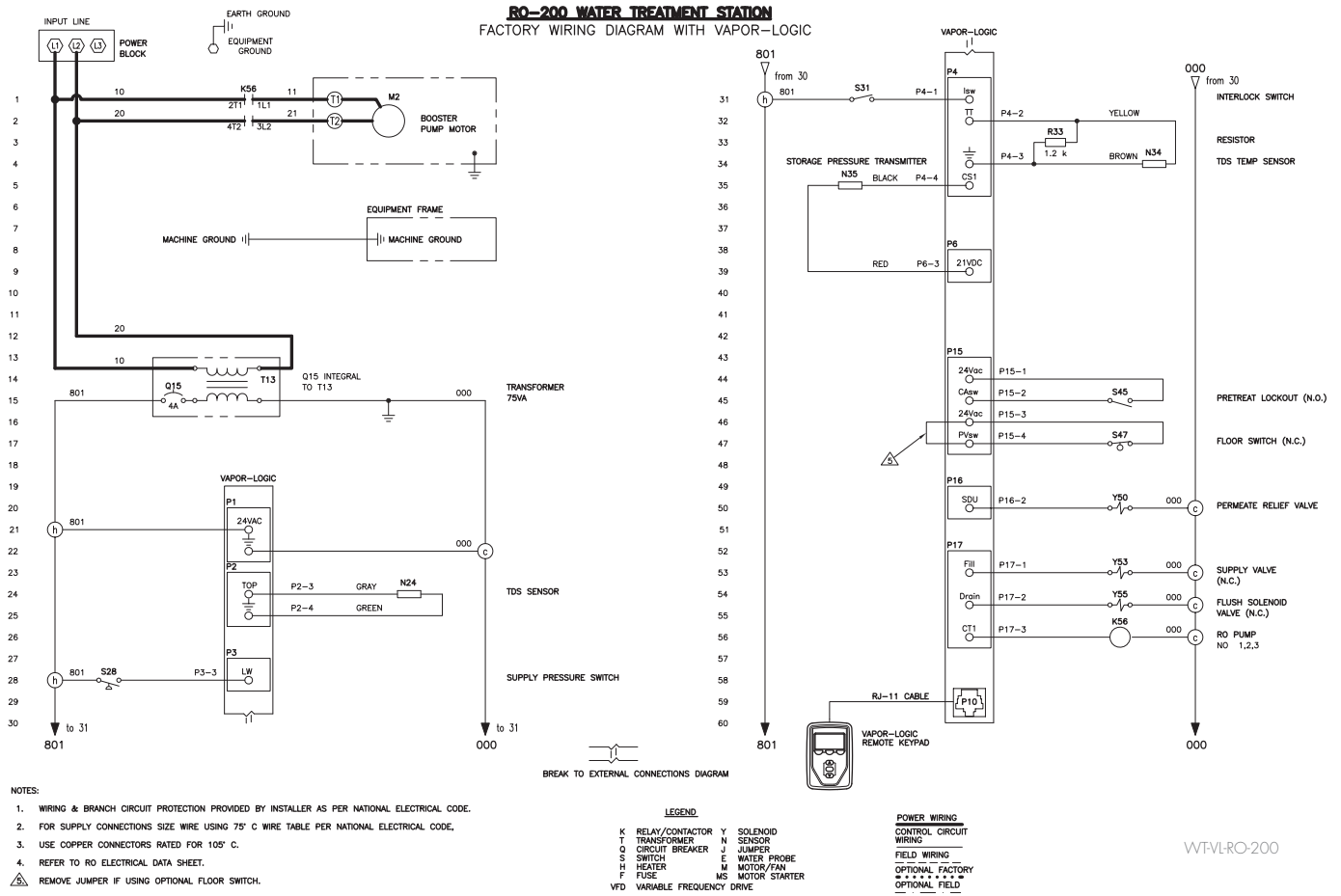

Table 8-1:
Component identification

	Item	Description
1	Vapor-logic keypad/display	Power On/Off and status display
2	Inlet solenoid valve	Normally closed. Opens when power is applied.
3	Cartridge filter pressure gauges	Measure the feed and effluent pressure of the cartridge filters. Pressure difference determines when cartridge change out is required.
4	Sediment filter	5 micron sediment filter.
5	Carbon filter	10 micron extruded carbon cartridge to remove chlorine and reduce organics from the feed stream.
6	Low pressure switch	Shuts the system down if the inlet pressure is lower than 8 psi (adjustable).
7	High pressure pump and motor	Rotary pump and motor to pressurize the incoming water.
8	Membrane modules	RO membrane elements housed in stainless steel pressure tubes.
9	System pressure gauges	Measure the system (feed) and concentrate (effluent) pressure of the membrane modules.
10	Concentrate to drain control valve	To adjust system pressure. Must not be completely closed when the system is in operation.
11	Concentrate recirc control valve	To adjust and maintain adequate flow thru membranes
12	TDS monitor	Monitors the feed and permeate water quality.
13	Permeate check valve	Prevents backflow into RO module.
14	Pipe drain	Drain assembly. Run to a floor drain.
15	Vapor-logic control board	The Vapor-logic control board is mounted inside the control cabinet.

Schematic drawing

FIGURE 9-1: CONTROLLER ELECTRICAL SCHEMATIC



Piping and instrumentation arrangement

FIGURE 10-1: FLOW SCHEMATIC WITH A CARTRIDGE DECHLORINATOR

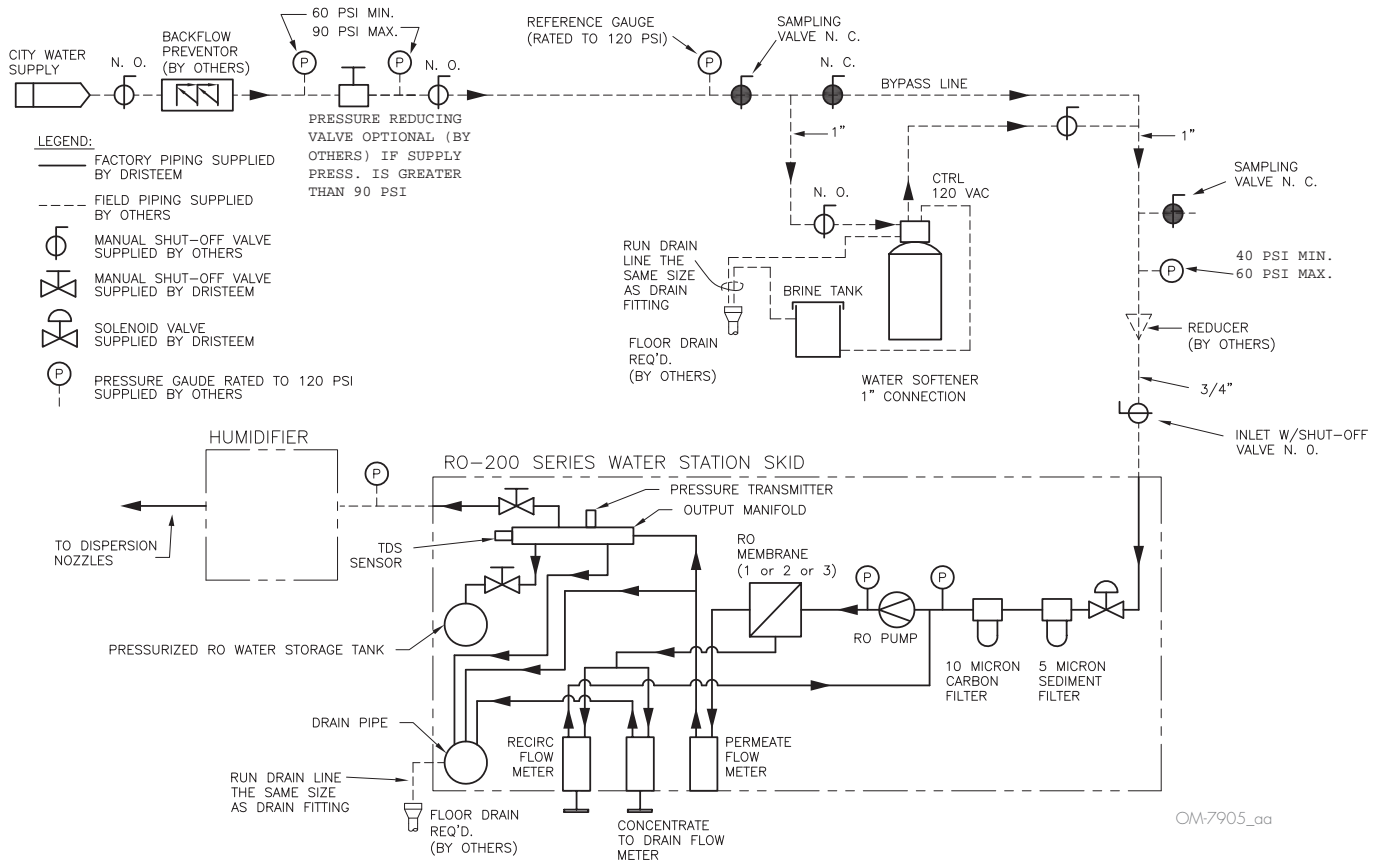

System operation

INITIAL SYSTEM START-UP

SYSTEM FLUSH

Direct permeate discharge to drain for first 30 minutes of operation.

1. Connect the system to the appropriate electrical outlet, 110-120 VAC or 208-240 VAC 1 phase.
2. Ensure all plumbing connections are open to allow flow. Open the concentrate valve (counterclockwise). Close the recirc valve (clockwise). Ensure sufficient pressure (40 psi recommended) is in feed line. If pressure is less than 8 psi, the low pressure switch will disallow start-up until pressure is adequate.
3. Press the power button; the solenoid will open and the unit will start operating.
4. After water is flowing from the concentrate line, adjust the concentrate control valve to obtain designated flow for the specific model (see Table 3-2 on page 3).
5. If required, adjust recirc control valve to meet desired flow rates (see Table 3-2 on page 3).
6. Allow the unit to run for 30 minutes to ensure proper flushing of system.
7. After the flush time is over, press the power button OFF.
8. Redirect the permeate line to the desired location.

NORMAL OPERATIONS

1. Turn the power back ON. After the pump starts, adjust the control valve to the desired flow/pressure (not to exceed 150 psi).
2. The recycle valve may now be adjusted to achieve desired recycle flow rate, ensuring concentrate flow rate is as specified.

SHUTDOWN

1. Press the power button to shut unit OFF. Close the isolation valve if it is installed on the feed line.
2. If the unit is to be shut down for more than one week, a membrane preservative should be used. To accomplish this, perform 30 second flush using cartridge filter insert (see page 25 for more information). After 30 seconds, press the power button OFF, and close the concentrate valve. This will hold the preservative in the pressure vessel.
3. When the system is restarted after an extended shutdown, follow initial system start-up procedures.

FIGURE 11-1: CONTROL VALVES

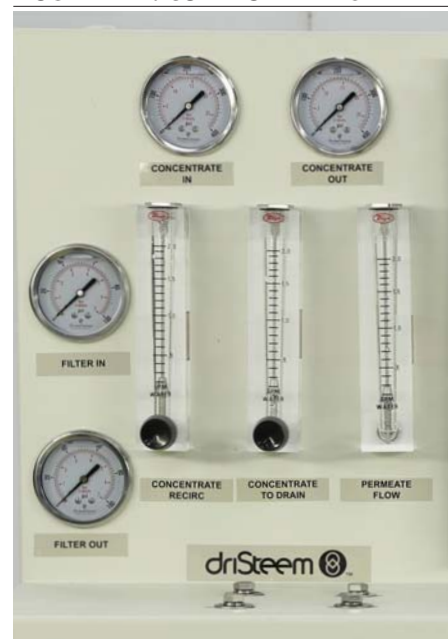

CAUTION

To prevent concentrate from precipitating and causing irreversible fouling of the RO membrane, do not operate the system with the control valve completely closed.

CAUTION

Do not exceed recommended maximum recovery.

Start-up checklist

If an item in the Start-up checklist below does not apply to your system, skip to the next item and continue the process.

- Read this manual and all other information that was provided with your system.
- Verify that all field wiring is done according to the instructions in this manual and in the unit wiring diagram.
- Confirm that proper grounding and an approved earth ground are provided.
- Confirm that the keypad/display is mounted with its modular cable routed away from high-voltage circuits and connected to the Display connector on the Vapor-logic board.
- Install cartridge filter and check for leaks.
- Precharge pressurized RO storage tank to 28 psi (195 kPa).
 Note: This precharge pressure is for pressurized RO storage tank cut-in and cut-out switch points at 30 and 50 psi (210 and 345 kPa) respectively.
- Turn on the water supply, and confirm there are no leaks.
- Turn on power to the unit, and confirm the Main menu is displayed on the keypad/display. The display may take several seconds to appear as the controller powers up.
- Confirm in the Main Menu that the mode is "Auto" and that status is "Idle."
- When "Idle" appears in main menu, confirm that the inlet pressure is at least 40 psi (276 kPa) on the display.
- With sufficient water available, the system in Auto mode, and the storage tank pressure less than 30 psi (210 kPa), verify that the pump is activated.
- Set perm flow and recirc flow meter to desired setting.
- Systems with tank-style carbon filter with control valve: Ensure that elastomeric Drain Line Flow Control restrictor washer is installed correctly in drain outlet plumbing assembly. This is required to prevent overflow and potential carry-over of carbon to the drain system.
- If you experience difficulties, have the keypad/display information available along with the serial number and unit Model, and call DriSteem Technical Support at 800-328-4447.
 Note: Instructions on how to properly care for the freeze protect chemical that is shipped with the system is available on the SDS sheet at www.dristeem.com.
- Inspect to insure that no flexible plumbing lines have been kinked or damaged during installation.

WARNING

Tipping hazard

Before installing the 200 series reverse-osmosis system, use supplied leg brackets or lag points to permanently fix the system to the floor and/or adjacent building structure. Failure to install according to instructions can result in serious injury or death. See page 10 for instructions.

Start-up

START-UP PROCEDURE

Check component installation per the layout shown in Figure 6-1 (depending on your model). After all components are installed and connected properly:

1. Perform all applicable "Start-up checklist" items on Page 12.
2. Read and follow instructions in the "Operation" section of *Vapor-logic Installation and Operation Manual*.

Note: During start-up, do not leave the system unattended.

TEST OPERATION

Using the keypad/display or web interface, place the zone controllers (if DriSteem controlled) and pump station in Auto mode. For each zone, perform the following procedure:

1. If the system has a full RO holding tank, create a call for water by draining water from the tank until the pressure falls below 30 psi (210 kPa).
2. Monitor system performance, and watch for leaks.
3. If a leak is found:
 - a. Remove demand signal, and put the system in Standby mode.
 - b. Tighten any loose connections.
 - c. Return system to Auto mode.
 - d. If a leak persists, replace tubing or fitting that is leaking.
4. Leave system in Auto mode. It will automatically refill the RO holding tank when pressure falls below 30 psi (210 kPa).

INITIAL SYSTEM START-UP

1. Close the manual valves to both the RO holding tank and all downstream equipment. Open the manual valve leading to the drain.
2. Open the feed water supply valve.
3. Open the system pressure (pump throttle) control valve fully counterclockwise (if applicable). Open the concentrate control valve fully counterclockwise. Close the recycle valve.
4. Put the system into 'Auto' mode. Note inlet water pressure must be at least 40 psi (276 kPa).
5. If incoming pressure is too high, an inlet pressure regulator (not included) may be installed. This should be set at 40 psi (276 kPa).
6. Some fittings may have loosened during shipment. Check for leaks at all tube fittings and threaded joints.
7. Allow the unit to run for at least 30 minutes to flush the preservative solution from the system.

Important

If the system is not in operation within six months of shipment, it is strongly recommended to use an organic cleaning cartridge prior to performing the start-up checklist to ensure proper operation. See page 12 for information and part number.

CAUTION

If the pump chatters loudly, it is starving for water (cavitating). Turn the unit OFF immediately to prevent pump damage. Correct the low pressure condition before proceeding.

FIGURE 13-1: SOLENOID VALVE INLET



CAUTION

Pump and system performance will be adversely affected if the feed/suction line is restricted.

Start-up

1. Once the preservative solution has been flushed from the system, shut down the system by putting the system into 'Standby' mode on the Vapor-logic keypad and close the manual valve going to the drain. Open the manual valves to both the RO storage tank and downstream equipment.
2. Run a ¾" MNPT from the stand pipe drain to an open drain.
3. Put the system back into 'Auto' mode.
4. Adjust the throttle valve to get the specified permeate flow (if applicable).
5. Adjust the concentrate valve and recycle valve until the specified permeate flow and recycle flow are obtained. It may be necessary to readjust the throttle valve. See Table 3-1.
6. Test the operation of the pressure switch by slowly closing the inlet water supply valve. The unit should shut off after a short 5 second time delay.
7. Once all the desired flows are set, allow the system to run for approximately 30 minutes. Then record the performance information using the system operation data log on page 27. The values recorded at startup will be important for determining system performance at a later date.

OPERATING DO'S AND DON'T'S

DO

1. Change the cartridge filters regularly
2. Monitor the system and keep a log daily
3. Run the system, as much as possible, on a continuous basis.
4. Adjust the system recovery to the recommended value

DON'T

1. Permit chlorine in the feed water.
2. Shut down the system for extended periods. If system will be down for more than one month, treat the system with a membrane preservative. See page 21 for instructions.
3. Close the throttle valve completely.
4. Operate the system with insufficient feed flow.

CAUTION

Do not operate the system with the control valve closed.

Important:

By setting the feed pressure as low as possible to meet the application requirement, the service life of the pump and RO elements will be optimized. The system should be run continuously when possible, rather than go through frequent start/stop cycles.

CAUTION

Damage to pump

Do not close the valve. Do not operate the pump below minimum combined flow rate (permeate + concentrate + recirculating).

CAUTION

Confirm all lines are connected before plugging in unit power.

Vapor-logic keypad/display

FIGURE 15-1: USING THE VAPOR-LOGIC KEYPAD/DISPLAY

Typical Home screen

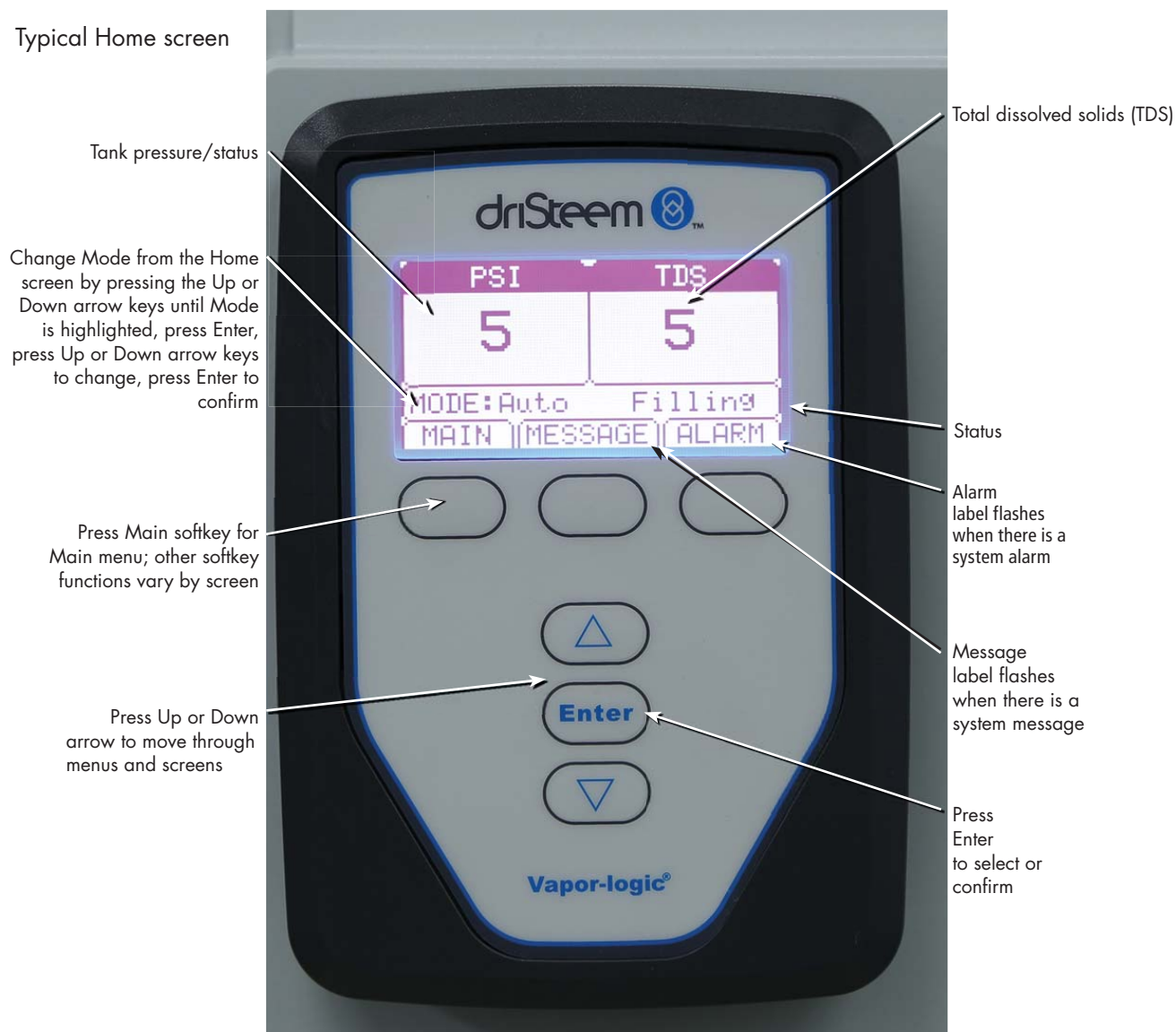

Keypad/display Home screens, Test outputs, Test run

Vapor-logic returns to the Home screen on the keypad/display after a user-defined period of idleness. The Home screen displays the items most frequently viewed.

CHANGING MODE

Mode can be changed from the Home screen. Press the Up or Down arrow key until the Mode is highlighted, press Enter, press Up or Down arrow key to change value, press Enter to confirm. All other parameters shown on the Home screen are for viewing only and cannot be changed. Go to the Setup menu to change these items.

CONTROLLER DISPLAY ACTIVITY DEFINITIONS

(Figure 16-1)

RO flush: System is performing an RO flush.

Idle: No demand, or an active alarm is preventing operation.

Filling: System is supplying high-pressure water to meet demand.

Full: Storage tank is full, system not running.

TEST OUTPUTS

When completing an installation or repair, cycle all outputs, to verify operation. Go to the test outputs section of the Diagnostics menu and scroll through each connected output to verify operation. During testing, the unit mode changes to Standby and the tank status changes to Test.

TEST RUN

Vapor-logic has a test run capability to confirm system functionality. This capability allows a technician to simulate a demand when there isn't one (such as when performing routine maintenance). To confirm functionality, go to the test run section of the Diagnostics menu. Set system demand percent and set test run time duration. During testing, the unit mode changes to Standby and the tank status changes to Test.

FIGURE 16-1: RO STATION KEYPAD/ DISPLAY HOME SCREEN



Status screen

Table 17-1:
Status screen

Note: Your system might not have all of the items listed in this table.

Menu item	Default value	Minimum value	Maximum value	Units	Notes
Run mode	Standby	-	-	-	<p>Operating mode of unit. Choose from Auto, Standby, or Drain.</p> <ul style="list-style-type: none"> In Auto mode, the unit operates normally. All unit components are monitored and controlled. If there is a call for cooling/humidification, the system reacts. In Standby mode, the unit is offline. All control inputs appear but are not acted upon; however, if the water temperature falls below the freeze protect set point, the drain valve opens. In Drain mode, the RO Flush valve opens, the RO tank drains, and the RO system begins making RO water. All unit operation is suspended, and the RO Flush valve remains open until the model specific RO flush time is met the unit is taken out of RO flush mode, or the RO tank is drained. See the Diagnostics section for information about Test outputs and Test run modes.
TDS	-	0	9999	ppm	
TDS set point	50	0	100	ppm	
Water temperature	-	-50	250	°F	Sensor range
	-	-46	121	°C	Sensor range
Safety interlock	Closed	Open	Closed	-	
Inlet pressure switch	-	No water	Water	-	
Storage pressure	-	0	100	psi	Storage tank pressure.
Pump hours	-	0	100,000	Hours	

Table 17-2:
Setup screen

Note: Your system might not have all of the items listed in this table.

Menu item	Default value	Minimum value	Maximum value	Units	Notes
Membrane flush	300	0	300	seconds	
System flush	72	1	336	hours	

Table 17-3:
TDS setting

Note: Your system might not have all of the items listed in this table.

Menu item	Default value	Minimum value	Maximum value	Units	Notes
High TDS causes	Alarm	Message	Alarm	-	
TDS setpoint	50	25	100	-	

Diagnostics and Alarms

Table 18-1:
Diagnostics menu

Note: Your system might not have all of the items listed in this table.

Message	Description	Auto-clear?
Pretreat lockout	Softener or other pretreatment is preventing the RO station from operation.	Yes
No master enable	Master enable for the system is open.	Yes
Excessive TDS	TDS measurement during RO production exceeds the TDS set point. The system will continue to operate but the membranes may need to be replaced.	Yes
Service unit	Regularly scheduled unit servicing is due.	No
Lock open	Interlock safety switch is open.	Yes

Notes:

- The Messages Log displays message name, date and time of occurrence, plus "Active," "Cleared" or "Auto-cleared."
- Active messages display first in the Messages Log, followed by cleared messages (auto-cleared and/or manually-cleared) listed in order of occurrence.
- The Messages Log displays a maximum of 10 messages. Cleared messages leave the log first.
- If a message event occurs and is not manually or auto cleared during unit operation, the message will stay there until there is demand and the unit is running.

Table 18-2:
Alarm menu

Alarm level	Description	Auto-clear?
Temp sensor fault	Water temperature/TDS sensor reading is out of range.	Yes
Low inlet pressure*	Water pressure at RO inlet is less than 10 psi.	Yes
High storage pressure	Tank storage pressure has exceeded 60 psi.	Yes
Floor sensor active	Optional flooded floor pan circuit is active.	No
Storage pressure sensor	Pressure sensor reading is out of range.	Yes
Excessive TDS	TDS measurement during RO production exceeds the TDS set point. The system will continue to operate but the membranes may need to be replaced.	No

Notes:

- See the "troubleshooting" section in the Vapor-logic Installation and Operation Manual for alarm possible causes and recommended actions.
- The Alarms Log displays alarm name, date, and time of occurrence, plus "Active," "Cleared," or "Auto-cleared."
- Active alarms display first in the Alarms Log, followed by cleared alarms (auto-cleared and/or manually-cleared) listed in order of occurrence.
- The Alarms Log displays maximum 30 alarms. Cleared alarms leave the log first.
- If an alarm event occurs and is not manually cleared or auto-cleared during unit operation, the alarm will remain until there is demand and the unit is running.

* Pressure alarm will occur if inlet pressure falls below 5 psi. Alarm will self-clear when RO system supply pressure is above 10 psi for at least 10 consecutive seconds. A pressure fault can be manually cleared at any time. System will try to operate every 10 consecutive seconds per hour up to 72 hours while in low pressure alarm condition.

Modbus, BACnet, LonTalk interoperability

Table 19-1:
Interoperability variable and object names

Variable name and BACnet object name	Read Only (RO) or Read Write (RW)	Modbus register number*	BACnet Object Type and Instance	LonTalk variable names**	Description	Units		Range	
						I-P units	SI units	I-P units	SI units
Read-only analog variables									
Storage_pressure	RO	IR-1	AI-1	nvoStoragePress	Storage pressure	psi	bar	0	100
Pump_1_hour	RO	IR-2	AI-2	nvoPumpHours	Hours of operation	hours	hours	0	100000
Water_temp	RO	IR-3	AI-3	nvoWaterTemp	Temperature of RO water	F	C	-50 to 250	-46 to 121
TDS	RO	IR-4	AI-4	nvoTDS	TDS	—	—	0	9999
Set Variables									
Run_mode	Write	HR-1	MSV-01	nviRunMode	Mode of the unit or system. The defined options are: 1=Auto; 2=Local standby; 3=System standby; 4=Manual drain; 5=Test outputs; 6=Test run	—	—	1 to 4	1 to 4
	Read	HR-1	MSV-01	nvoRunMode	Mode of the unit or system. The defined options are: 1=Auto; 2=Local standby; 3=System standby; 4=Manual drain; 5=Test outputs; 6=Test run			1 to 6	1 to 6
TDS_setpoint	RW	HR-2	AV-1	nviTDS_SP	TDS set point	—	—	0	75
Read-only digital I/O									
Safety_interlock	RO	DI-1	BI-01	nvoLockSW	0=Open; 1=Closed	—	—	—	—
Pretreat_lockout_sw	RO	DI-2	BI-02	nvoPreTreatSW	0=Open; 1=Closed	—	—	—	—
Floor_water_sw	RO	DI-3	BI-03	nvoFloorSW	0=Water; 1=No Water	—	—	—	—
Inlet_pressure_sw	RO	DI-4	BI-04	nvoInletPressSW	0=No Water; 1=Water	—	—	—	—
Master_enable_sw	RO	DI-5	BI-05	nvoMasterEnabSW	0=Open; 1=Closed	—	—	—	—
Supply_valve	RO	DI-6	BO-01	nvoSupplyValve	0=Open; 1=Closed	—	—	—	—
Drain_valve	RO	DI-7	BO-02	nvoDrainValve	0=Open; 1=Closed	—	—	—	—
RO_pump	RO	DI-8	BO-03	nvoROpump	0=Off; 1=On	—	—	—	—
Notes:									
1. Modbus Input Registers (IR1-IR4) 16 bit read only Modbus Holding Registers (HR1-HR2) 16 bit read/write Modbus Discrete Input Registers (DI1-DI8) single bit read only Modbus Coil Registers (DV1-DV8) single bit read/write									
2. nvi LonTalk SNVTs are write-only; nvo are read-only									

Modbus, BACnet, LonTalk interoperability

Table 19-1:
Interoperability variable and object names

Variable name and BACnet object name	Read Only (RO) or Read Write (RW)	Modbus register number*	BACnet Object Type and Instance	LonTalk variable names**	Description	Units		Range	
						I-P units	SI units	I-P units	SI units
Faults and Alarms									
ProgOutput1_status	RW	DV-01	BV-01	nvoDryConStat1	NO or NC output	—	—	—	—
ProgOutput2_status	RW	DV-02	BV-02	nvoDryConStat2	No or NC output	—	—	—	—
Active_manually_cleared_alarm_exists	RW	DV-03	BV-03	nvoAlarmManCl	Flags all manually cleared alarms	—	—	—	—
Clear_all_faults	RW	DV-04	BV-04	nviClrAllFault	When set will clear all active faults	—	—	—	—
Alarm_temp_sensor_failed	RW	DV-05	BV-05	nvoAlmTempSense	See Table 18-2: Alarm menu	—	—	—	—
Alarm_low_inlet_pressure	RW	DV-06	BV-06	nvoAlmInPress	See Table 18-2: Alarm menu	—	—	—	—
Alarm_excessive_storage_pressure	RW	DV-07	BV-07	nvoAlmOutPress	See Table 18-2: Alarm menu	—	—	—	—
Alarm_floor_water_sensor_activated	RW	DV-08	BV-08	nvoAlmFloorWet	See Table 18-2: Alarm menu	—	—	—	—
Alarm_pressure_sensor_out_of_range	RW	DV-09	BV-09	nvoAlmPrSensOOR	See Table 18-2: Alarm menu	—	—	—	—
Alarm_excessive_TDS_during_fill	RW	DV-10	BV-10	nvoAlmExcessTDS	See Table 18-2: Alarm menu	—	—	—	—
Message_pretreat_lockout_active	RW	DV-11	BV-11	nvoMsgPretreatL	See Table 18-1: Diagnostics menu	—	—	—	—
Message_excessive_TDS_during_fill	RW	DV-12	BV-12	nvoMsgExcessTDS	See Table 18-1: Diagnostics menu	—	—	—	—
Message_service_unit	RW	DV-13	BV-13	nvoMsgSrviceUnt	See Table 18-1: Diagnostics menu	—	—	—	—
Message_interlock_open	RW	DV-14	BV-14	nvoMsgIlockOpen	See Table 18-1: Diagnostics menu	—	—	—	—
Message_master_enable_open	RW	DV-15	BV-15	nvoMsgNoMastEnb	See Table 18-1: Diagnostics menu	—	—	—	—
Notes: 1. Modbus Input Registers (IR1-IR11) 16 bit read only Modbus Holding Registers (HR1-HR10) 16 bit read/write Modbus Discrete Input Registers (DI1-DI9) single bit read only Modbus Coil Registers (DV1-DV15) single bit read/write 2. nvi LonTalk SNVTs are write-only; nvo are read-only									

Maintenance information

MAINTENANCE TIPS

Maintain proper operating conditions:

- Do not exceed 60-90 psi (414-620 kPa) on the system inlet pressure gauge.
- Do not over use recycle flow. This can cause premature scaling of the membrane. A proper concentrate flow is required for a long membrane life. See page 3 for maximum recycle flow.
- To ensure no chlorine reaches the RO membranes, test the water from your dechlorinator periodically for chlorine break through.

WHEN TO CHANGE SEDIMENT AND CARBON FILTERS

Sediment and carbon filters should be changed regularly to maintain proper pressure and flow and water quality.

Change the carbon filter when chlorine from supply water starts to pass through. The carbon filter removes chlorine. Check regularly for chlorine pass through. To check for chlorine, obtain a water sample from the concentrate drain line and test the water. If chlorine is present, change the carbon filter and record the interval to estimate the next carbon filter change.

Change the sediment filter when the difference between filter pressure gauge increases by 10 psi over the initial pressure difference. For example, if initial readings are 60 psi in and 58 psi out, the difference is 2 psi. Therefore, when that difference reaches 12 psi, it is time to replace the sediment and carbon cartridges.

CHANGING CARTRIDGE FILTERS

1. Put the system into 'Standby' mode and shut down the RO system.
2. Close inlet supply valve.
3. Un-assemble the filter housing (twist the sump counter-clockwise).
4. Remove and inspect the cartridge. Replace as needed.
5. Before replacing housing, insure that O-ring seal is lubed and placed in groove of housing. Inspect seal and replace as needed.
6. Assemble housing (turn the sump clockwise into the cap until tight).

Important: Verify regularly that water processing equipment is operating correctly. The presence of chlorides in improperly process deionized water will eventually cause pitting and failure of the equipment the RO system is servicing and its components. Damage cause by chloride corrosion is not covered by your DriSteem warranty. The RO system has an automatic drain sequence (ADS) set based on default supply concentration of 20 ppm. Adjust ADS to actual supply water connection.

FIGURE 21-1: SEDIMENT FILTER



DriSteem replacement part
• 4" x 10" - (part number: 550026-004)

FIGURE 21-2: CARBON FILTER



DriSteem replacement part
• 4" x 10" - (part number: 550027-004)

CAUTION

Chlorine can damage the membrane. A carbon pre-filter is installed to remove chlorine from fee water. Care must be taken to change this carbon filter as needed to accomplish effective chlorine removal. Excessive chlorine in feed stream may require additional pre-filtration. The feed stream should be tested for chlorine at least once a week. Always follow proper maintenance procedures.

Maintenance continued

WHEN TO CLEAN OR REPLACE MEMBRANES

In normal operation, the membrane in reverse osmosis elements can become fouled by mineral scale, biological matter, and grime. These deposits build up during operation until it causes loss in water output or loss of salt rejection, or both. Elements should be cleaned or replaced whenever the water output rate drops by 10 percent from its initial flow rate (the flow rate established during the first 24 to 48 hours of operation) or when TDS in the product water (permeate) rises above 50. This is indicated through a message on the Vapor-logic controller (above 75 will alarm).

It should be noted that the water output rate will drop if feed water temperature decreases (about 1.5% per °F). This is normal and does not indicate membrane fouling. A malfunction in the pretreatment, pressure control or pump can cause a drop in feed water delivery pressure, feed water flow, product water output, or an increase in salt passage. If such adjustments are needed, the element may not require cleaning.

REPLACING MEMBRANES

TOOLS

- Rubber mallet
- Flat blade screwdriver
- Open end wrench, 7/8 inch
- Food grade RT-111 silicone
- Safety glasses

PROCEDURE

1. Turn OFF the RO system.
2. Relieve pressure on the membrane by opening the supply valve.
3. Remove all lines from the top of the pressure vessel(s). Make sure the fittings are marked so the fittings go back to the correct locations after replacing.
Note: Membranes on RO system are removed and inserted from the top.
4. Remove end plugs by pulling carefully. See Figure 22-2.

FIGURE 22-1: PRE-FILTER



1. Sediment filter:
Removes sediments and particles down to 5 micron size.
2. Carbon filter:
Primarily to remove chlorine; also removes organics and sediments down to 10 microns.

FIGURE 22-2: DRISTEEM REVERSE OSMOSIS MEMBRANES



Maintenance continued

MEMBRANE CLEANING IN THE RO SYSTEM

Membrane cleaning cartridges:

- Clean membranes without having to remove them from the RO system
- Reduce downtime
- Maintain the system performance at a higher level
- Prolong membrane life by regular use of cleaning cartridges

HOW DOES IT WORK?

NOTE: Clean monthly to obtain optimum results.

1. Exchange the system's sediment filter with a cleaning cartridge.
2. Follow the instructions.
3. Restart the system.
4. Repeat the process if required.

SCALE CLEANING CARTRIDGE

The scale cleaning cartridge is for removal of mineral scale and build-up.

CLEANING PROCEDURE

1. Put the system into 'Standby' mode and shutdown the RO system.
2. Disconnect permeate line and divert to drain before any cleaning cartridge is installed.
3. Remove the sediment filter from the pre-filter housing.
4. Replace the sediment filter with the cleaning cartridge and assemble into the filter housing.
5. Turn the system ON and put into 'Auto' mode. After 30-40 seconds, shut down the system.

OPTIONAL: Instead of time, use one of the following criteria:

 - a. Run the system until the pH of the concentrate is almost the same as the cleaning solution (pH=3)
 - b. Permeate rate for the system drops to a very low value.
6. Let the membrane(s) soak in the cleaning solution overnight.
7. Remove the empty cleaning cartridge and replace it with the original filter.
8. Restart the system. Direct the permeate to drain for five minutes.
9. Go back to normal operations.

FIGURE 23-1: 10 INCH SCALE CLEANING CARTRIDGE



DriSteem replacement part
 • 4" x 10" - (part number: 550045-202)

CAUTION

Handle all chemicals with care. Wear protective clothing and eye protection.

CAUTION

The system must be flushed thoroughly between acid and alkaline cleaning.

Maintenance continued

ORGANIC CLEANING CARTRIDGE

The organic cleaning cartridge is for removal of organics/fouling.

CLEANING PROCEDURE

1. Put the system into 'Standby' mode and shutdown the RO system.
2. Disconnect permeate line and divert permeate to drain during cleaning.
3. Remove the sediment filter from the filter housing.
4. Replace the sediment filter with the cleaning cartridge and assemble into the filter housing.
5. Turn the system ON. After 30-40 seconds, shut down the RO system.
 OPTIONAL: Instead of time, use one of the following criteria:
 - a. Run the system until the pH of the concentrate is almost the same as the cleaning solution (pH=10-12)
 - b. Permeate rate for the system drops to a very low value.
6. Let the membrane(s) soak in the cleaning solution overnight.
7. Remove the empty cleaning cartridge and replace it with the original filter.
8. Restart the system. Direct the permeate to drain for five minutes.
9. Go back to normal operations.

FIGURE 24-1: 10 INCH ORGANIC CLEANING CARTRIDGE



DriSteem replacement part
 • 4" x 10" - (part number: 550045-701)

CAUTION

Handle all chemicals with care. Wear protective clothing and eye protection.

CAUTION

The system must be flushed thoroughly between acid and alkaline cleaning.

Storage

To prevent bacterial growth and help maintain flux, it is recommended that elements be immersed in a preservative solution if the system will be OFF for more than one week.

MEMBRANE PRESERVATIVE CARTRIDGE

PRESERVING PROCEDURE

1. Shut down the RO system.
2. Disconnect the permeate line and direct permeate to drain during cleaning/preserving.
3. Remove the 5M filter cartridge from the pre-filter housing.
4. Replace the filter cartridge with the preservative cartridge and assemble into the filter housing.
5. Turn the system ON. After 30-40 seconds, shut down the system.
6. Drain the system of the permeate solution as much as possible by opening a valve/fitting at a low point in the system.
7. Close OFF the inlet and outlet to the membrane/system.

FLUSHING OUT PRESERVATIVE/RESTART PROCEDURE

8. Open valves and put the system back in the position it was before preserving.
9. Remove the empty preservative cartridge and replace it with a new cartridge filter.
10. Restart the system. Direct permeate to drain for 15-30 minutes.
11. Go back to normal operation.

FIGURE 25-1: 10 INCH BIG BLUE CLEANING CARTRIDGE



DriSteem replacement
part number 550045-902.

System monitoring and record keeping

The system should be monitored and all pertinent data recorded on a daily basis. This includes cartridge filter pressure in/out, system pressure in/out, flow and water quality (TDS) in/out. Data is needed to determine operating efficiency and for performing system maintenance. The latter includes cleaning of the membranes, adjusting the operating conditions as well as replacement of cartridge filters and RO membranes.

**Table 26-1:
Troubleshooting**

Issue	Possible Cause	Solution
Inlet pressure low*	Low supply pressure	Correct incoming supply pressure
	Cartridge filters plugged	Change filters
	Solenoid valve malfunction	Replace solenoid valve and/or coil
Permeate flow low	Low water temperature	Adjust water temperature
	Low system pressure	Adjust concentrate control valve
	Membranes fouled	Clean membranes
Pump noisy	Low inlet flow	See "Inlet pressure low"
Permeate quality poor	Low inlet flow	Adjust concentrate control valve
	Low system pressure	See "Inlet pressure low"
	Recovery too high	Reduce recirculation control valve
	Membranes fouled	Clean membranes
	Membranes damaged	Replace membranes

* Pressure alarm will occur if inlet pressure falls below 5 psi. Alarm will self-clear when RO system supply pressure is above 10 psi for at least 10 consecutive seconds. A pressure fault can be manually cleared at any time. System will try to operate every 10 consecutive seconds per hour up to 72 hours while in low pressure alarm condition.

System operating log

Table 27-1:
System operating log

Date							
Time							
Chlorine							
Cartridge in psi							
Cartridge out psi							
Water temperature							
TDS in							
TDS out							
System psi							
Concentrate psi							
Cartridge filter change							
Membrane change							
Recorded by							

Notes

Water quality test strips

WATER QUALITY TEST STRIPS SAMPLE PACK

- Carbon filters in the RO-200 water treatment system should be changed regularly to maintain proper pressure and flow and water quality.
- The carbon filter removes chlorine. Change the carbon filter when chlorine from supply water starts to pass through. Check regularly for chlorine pass through.
- To check for chlorine, obtain a water sample from the concentrate drain line and test the water. If chlorine is present, change the carbon filter and record the interval to estimate the next carbon filter change.
- For best results, test water chlorine every two weeks.
- To order more Water Quality Test Strips, contact your local DriSteem rep, or call 1-800-328-4447.

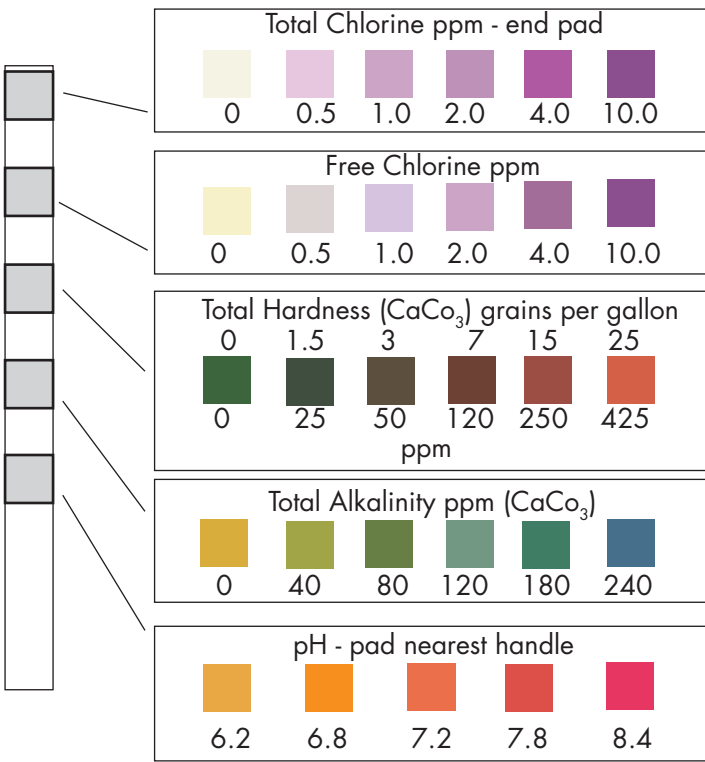

DIRECTIONS:

1. Dip entire strip into water for 1 second (or pass under water stream), remove. Do not shake excess water from the test strip. Hold the strip for 30 seconds.
2. Compare TOTAL HARDNESS, TOTAL ALKALINITY and pH pads to color chart to the left.
3. Dip strip into the water again and move back and forth for 30 seconds (or hold two chlorine pads under water stream for 10 seconds).
4. Compare CHLORINE pads to color chart to the left.
5. Track results in the chart below.
6. Change the carbon cartridge filter once chlorine is detected in the concentrate water of the RO 200 water treatment system (see page 21).

Table 28-1:
Water quality test log

Date tested	Total chlorine ppm	Free chlorine ppm	Total hardness	Total alkalinity	pH
Week 1 _____					
Week 3 _____					
Week 5 _____					
Week 7 _____					
Week 9 _____					
Week 11 _____					

RO system (Models 201, 202, and 203)

Table 30-1:
RO system replacements parts

No.	Description	Qty.	Part No.
1	Pump motor 1/3 hp, 100-120/200-240V	1	400292-001
2	Pump rotary vane brass 95 gph	1	400294-001
	Pump rotary vane brass 105 gph	1	400294-002
3	Gauge liquid filled 400 psi pnl mnt kit	2	260004-400
4	Gauge liquid filled 100 psi pnl mnt kit	2	260004-100
5	Meter 2 gpm water flow ¼" FNPT	1	501907-302
6	Meter 2 gpm water flow with needle valve ¼" FNPT	2	501907-402
7	Plumb filter dechlor/carbon 4" x 10"	1	550027-004
8	Plumb filter sediment 5 micron 4" dia x 10"	2	550026-004
9	Housing filter 4.5" dia x 10"	2	550028-008
10	Membrane RO 2.5" x 21" extra low energy	1	550035-025
11	Vessel assembly 2.5" X 23-5/16"	Varies	550038-025
12	Tank water pressurized 4.4 gal	1	550029-004
13	Manifold assembly output RO-200 standalone	1	187714-002
14	Pressure switch assy RO-200	1	187716-001
15	Drain assy RO-200 2"	1	165103-001
16	Valve 1/2" solenoid two-way n.c. 3.35 CV	1	505107-050

* Specify RO system model and serial numbers when ordering.

Subpanel

FIGURE 31-1: CONTROL CABINET ASSY RO-200

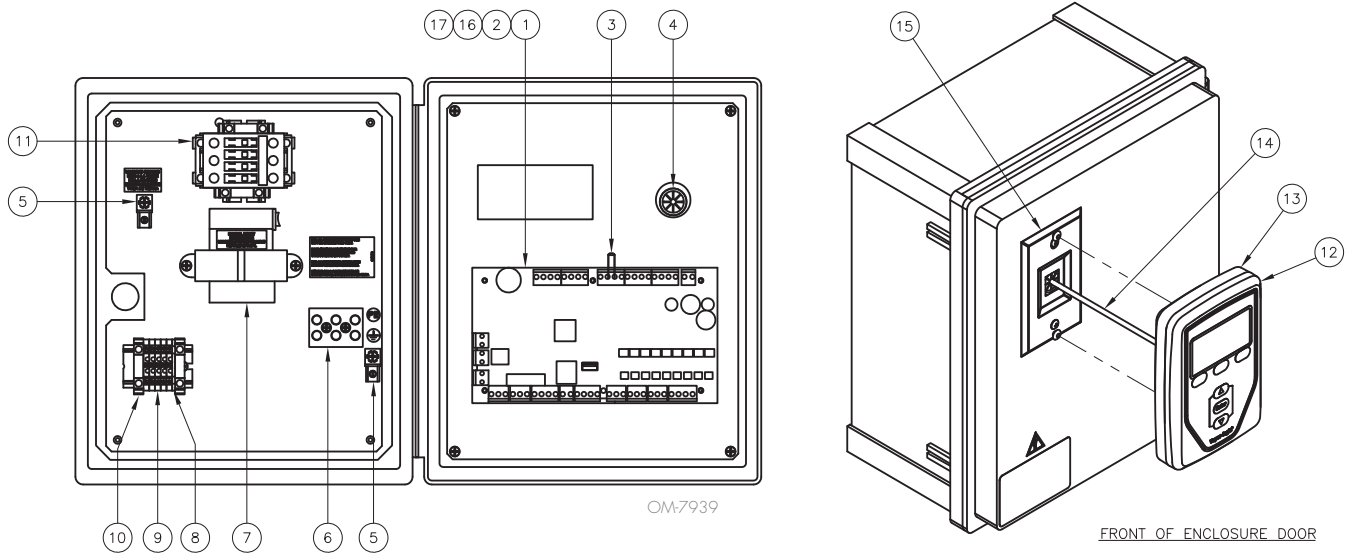

Table 31-1:
Control cabinet assy RO-200

No.	Description	Qty.	Part No.	No.	Description	Qty.	Part No.
1	Main controller VL6	1	408496-006	9	Terminal DIN rail 20A center	1	408252-001
2	Module LON protocol (LON option only)	1	408642	10	Terminal DIN rail end	1	408252-006
3	Resistor 1.2K OHM through hole	1	408995-008	11	Contactor 35A SIEMENS	1	407010-001
4	Bushing 7/8" shutter HEYCO	1	407129	12	Display VL w/o back Vapor-logic	1	408495-002
5	Lug medium	1	409250-027	13	Case rear display Vapor-logic	1	408495-003
6	Terminal block 3 pole pressure contact	1	408300-002	14	Wire data cable 27" RJ-12	1	408490-014
7	Transformer 120/208/240/480V TO 24VAC 75V	1	408965-001	15	Mount wallplate wallphone SST	1	408490-021
8	Terminal DIN rail end cap	1	408252-005	16	Plug 3 circuit vertical euro molex	1	406246-003
				17	Plug 4 circuit vertical euro molex	1	406246-004

Expect quality from the industry leader

Since 1965, DriSteem has led the industry with innovative methods for humidifying and cooling air with precise control. Our focus on ease of ownership is evident in the design of our Water Treatment Systems, which feature low maintenance and comprehensive control. DriSteem also leads the industry with a Two-year Limited Warranty and optional extended warranty.

For more information

www.dristeem.com
sales@dristeem.com

For the most recent product information visit our Web site: www.dristeem.com

DRI-STEEM Corporation

a subsidiary of Research Products Corporation
DriSteem is an ISO 9001:2008 certified company

U.S. Headquarters:

14949 Technology Drive
Eden Prairie, MN 55344
800-328-4447 or 952-949-2415
952-229-3200 (fax)

European office:

Grote Hellekensstraat 54 b
B-3520 Zonhoven
Belgium
+3211823595 (voice)

E-mail: dristeem-europe@dristeem.com

Continuous product improvement is a policy of DriSteem; therefore, product features and specifications are subject to change without notice.

DriSteem and Vapor-logic are registered trademarks of Research Products Corporation and are filed for trademark registration in Canada and the European community.

Product and corporate names used in this document may be trademarks or registered trademarks. They are used for explanation only without intent to infringe.

© 2018 Research Products Corporation

Form No. RO-200-IOM-EN-0318
Part No. 890000-875 Rev C

Two-year Limited Warranty

DRI-STEEM Corporation ("DriSteem") warrants to the original user that its products will be free from defects in materials and workmanship for a period of two (2) years after installation or twenty-seven (27) months from the date DriSteem ships such product, whichever date is the earlier.

If any DriSteem product is found to be defective in material or workmanship during the applicable warranty period, DriSteem's entire liability, and the purchaser's sole and exclusive remedy, shall be the repair or replacement of the defective product, or the refund of the purchase price, at DriSteem's election. DriSteem shall not be liable for any costs or expenses, whether direct or indirect, associated with the installation, removal or reinstallation of any defective product. Excluded from the Limited Warranty are all consumable and wear and tear items such as cylinders, membranes, filters, or media replacements. These items are subject to usual wear and tear during usage.

DriSteem's Limited Warranty shall not be effective or actionable unless there is compliance with all installation and operating instructions furnished by DriSteem, or if the products have been modified or altered without the written consent of DriSteem, or if such products have been subject to accident, misuse, mishandling, tampering, negligence or improper maintenance. Any warranty claim must be submitted to DriSteem in writing within the stated warranty period. Defective parts may be required to be returned to DriSteem.

DriSteem's Limited Warranty is made in lieu of, and DriSteem disclaims all other warranties, whether express or implied, including but not limited to any IMPLIED WARRANTY OF MERCHANTABILITY, ANY IMPLIED WARRANTY OF FITNESS FOR A PARTICULAR PURPOSE, any implied warranty arising out of a course of dealing or of performance, custom or usage of trade.

DriSteem SHALL NOT, UNDER ANY CIRCUMSTANCES BE LIABLE FOR ANY DIRECT, INDIRECT, INCIDENTAL, SPECIAL OR CONSEQUENTIAL DAMAGES (INCLUDING, BUT NOT LIMITED TO, LOSS OF PROFITS, REVENUE OR BUSINESS) OR DAMAGE OR INJURY TO PERSONS OR PROPERTY IN ANY WAY RELATED TO THE MANUFACTURE OR THE USE OF ITS PRODUCTS. The exclusion applies regardless of whether such damages are sought based on breach of warranty, breach of contract, negligence, strict liability in tort, or any other legal theory, even if DriSteem has notice of the possibility of such damages.

By purchasing DriSteem's products, the purchaser agrees to the terms and conditions of this Limited Warranty.

Extended warranty

The original user may extend the term of the DriSteem Limited Warranty for a limited number of months past the initial applicable warranty period and term provided in the first paragraph of this Limited Warranty. All the terms and conditions of the Limited Warranty during the initial applicable warranty period and term shall apply during any extended term. An extended warranty term of an additional twelve (12) months or twenty four (24) months of coverage may be purchased. The extended warranty term may be purchased until eighteen (18) months after the product is shipped, after which time no extended warranties are available. When a DriSteem humidifier is purchased with a DriSteem RO system, an extended twenty-four (24) month coverage is included.

Any extension of the Limited Warranty under this program must be in writing, signed by DriSteem, and paid for in full by the purchaser.