

# CONDENSATE MANAGEMENT: ATMOSPHERIC STEAM SYSTEMS

#1: Dispersion panel - separate drains

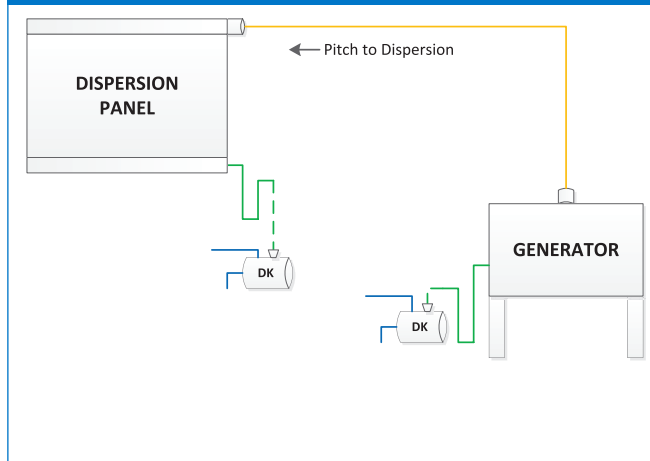

#2: Dispersion panel - common drain

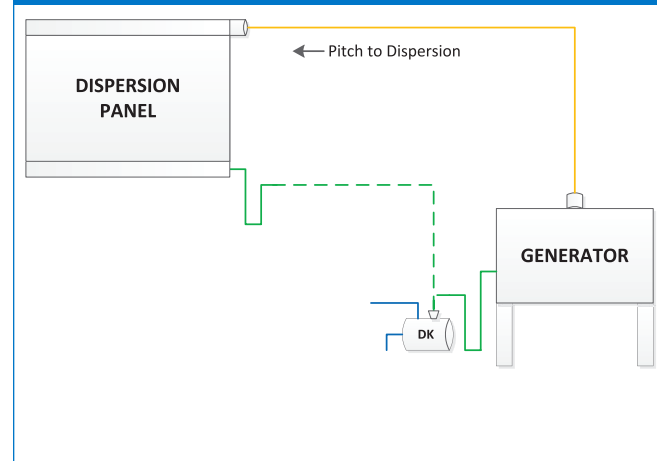

#3: Single dispersion tube

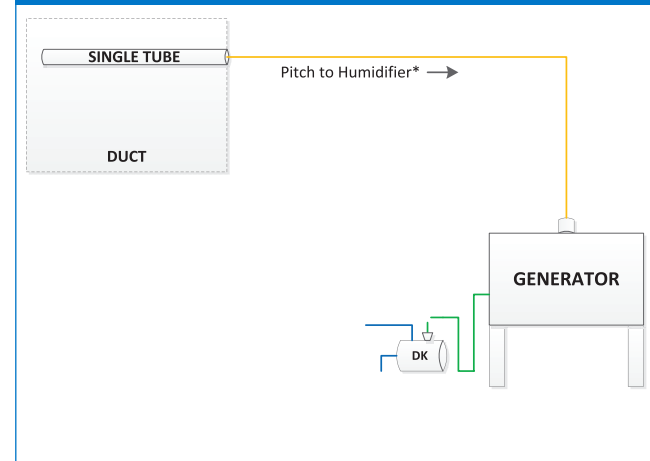

#4: Single dispersion tube with drain - separate drains

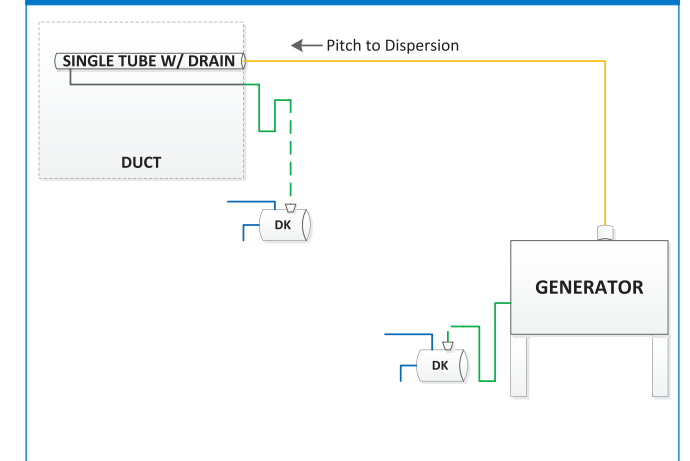

#5: Space distribution unit - separate drains

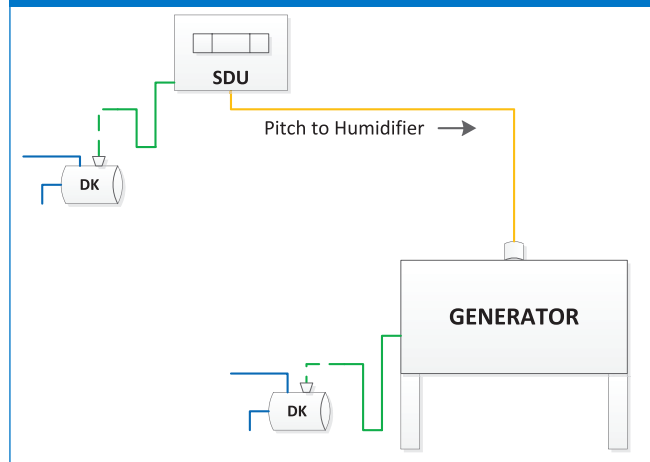

#6: Single dispersion tube with drain - common drain

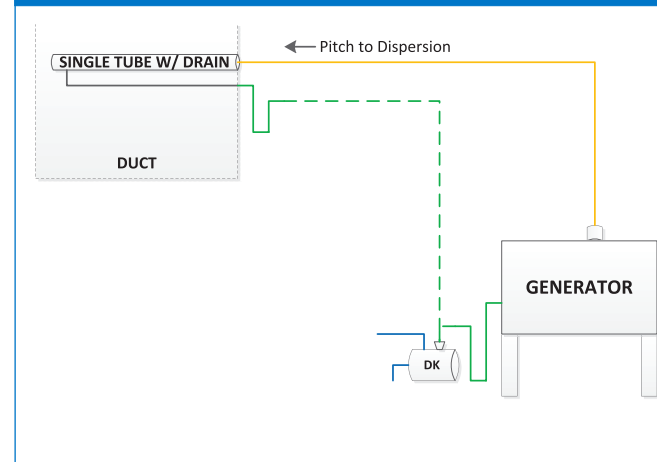

#7: Space distribution unit - common drain

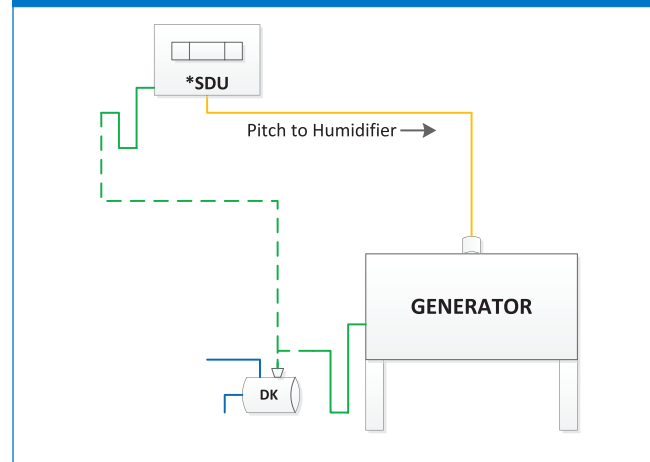

#8: Space distribution unit - XT units

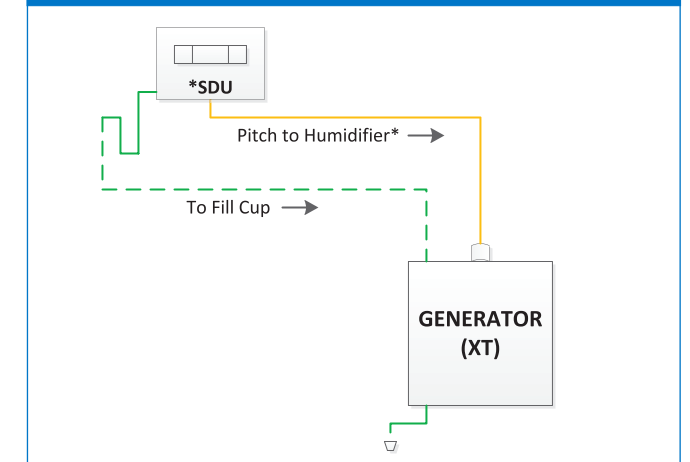

#9: Dispersion with obstruction - separate drain

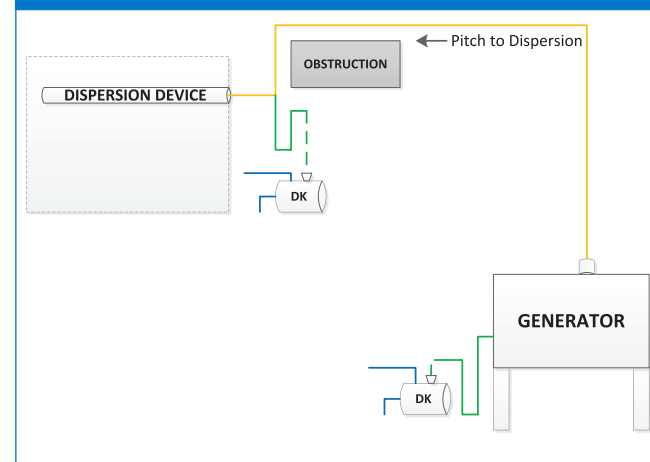

#10: Dispersion with obstruction - common drain

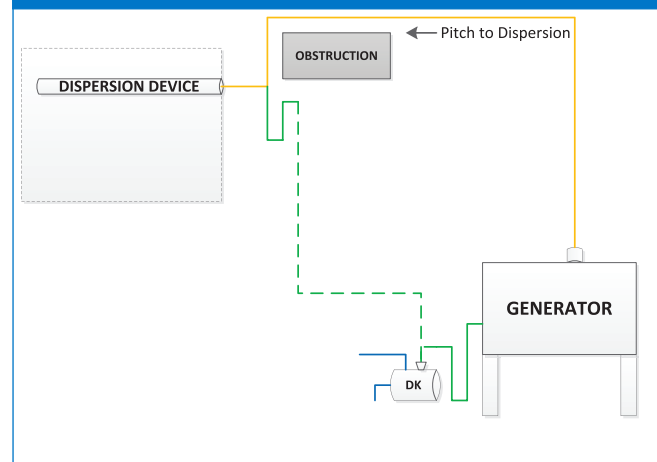

#11: Dispersion device with integral return - Vaporstream

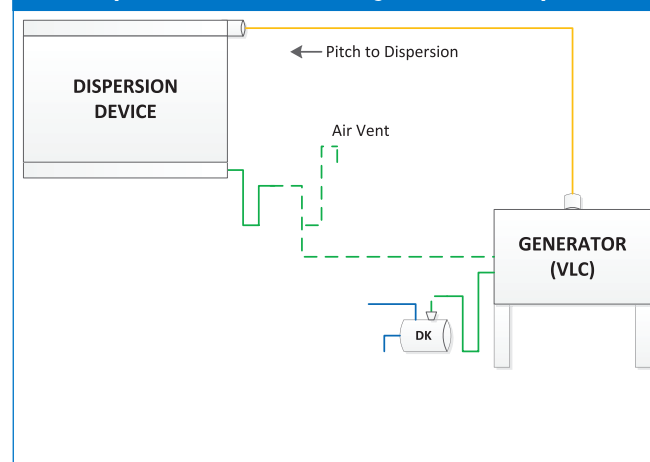

LEGEND	
	Non Pressurized Steam
	Non Pressurized Condensate
	Cold Water

**Notes:**

1. The Drane-kooler™ water tempering device can be replaced with a standard drain.
2. Check with local code for maximum discharge drain temperature.
3. XT humidifiers and GTS® humidifiers include a tempered drain.
4. Vaporstream® humidifiers have the ability to return condensate directly to the tank.

\* Electrode humidifier (XT) with capacity > 20 lbs/hr must be pitched to dispersion.

# CONDENSATE MANAGEMENT: PRESSURIZED STEAM SYSTEMS

#1: Dispersion panel - separate drains

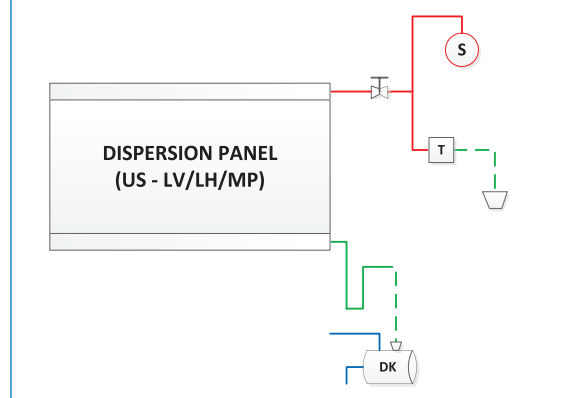

#2: Dispersion panel - to condensate main

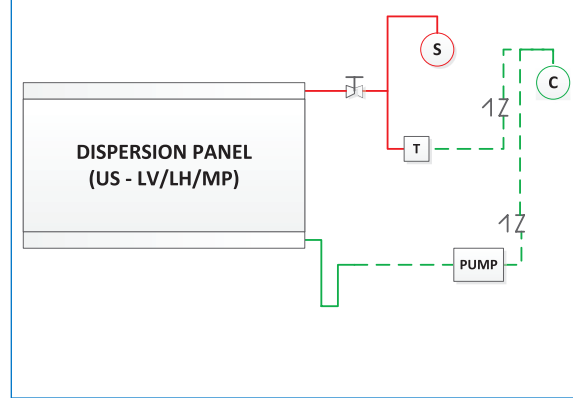

#3: Ultra-sorb XV - separate drains

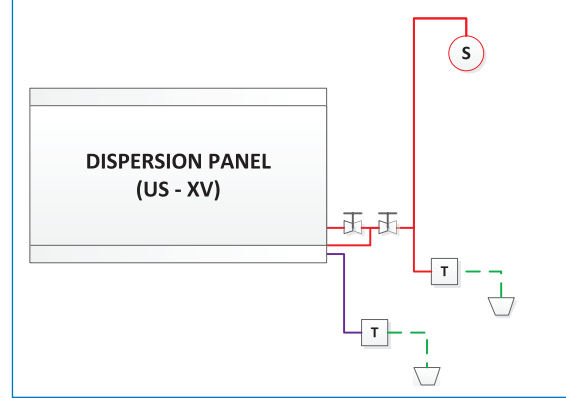

#4: Ultra-sorb XV - to condensate main

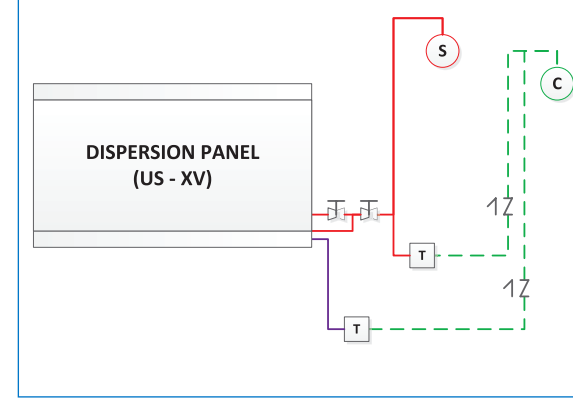

#5: Single tube - to drain

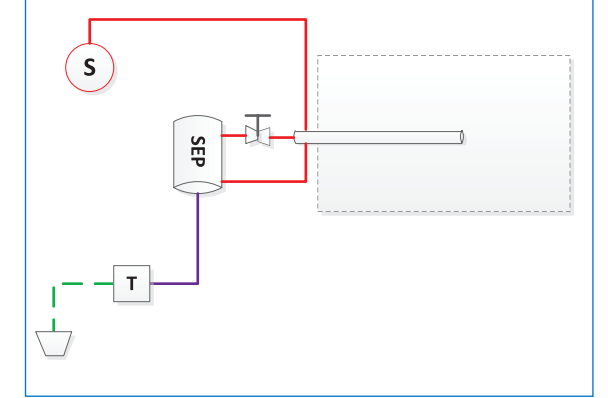

#6: Single tube - to condensate main

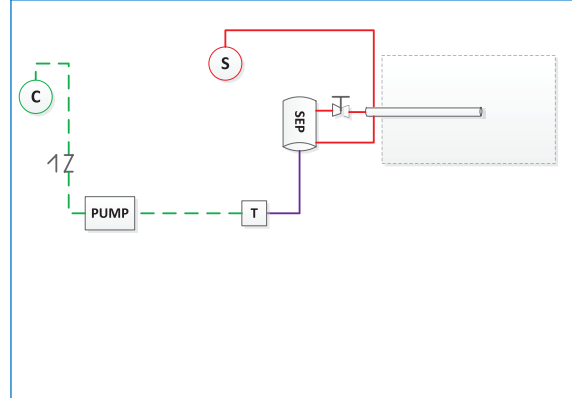

#7: Area type - to drain

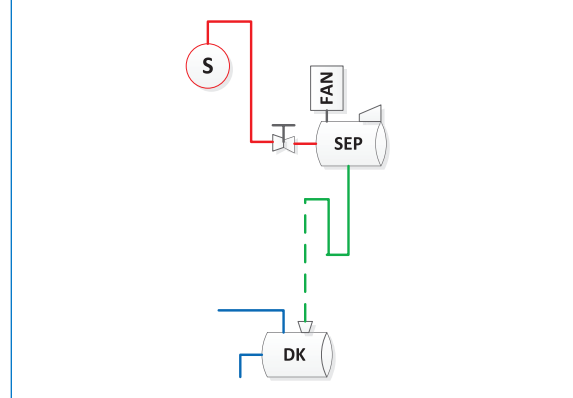

#8: Area type - to condensate main

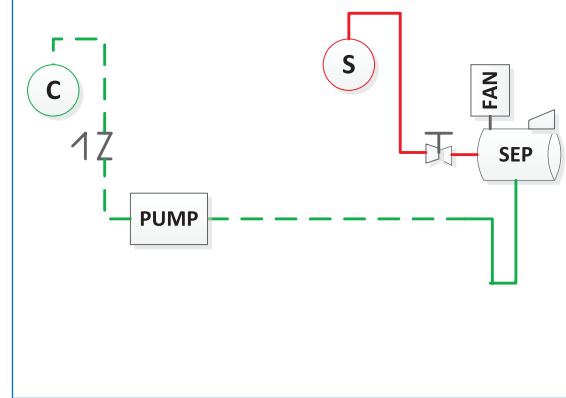

#9: Separator - to drain

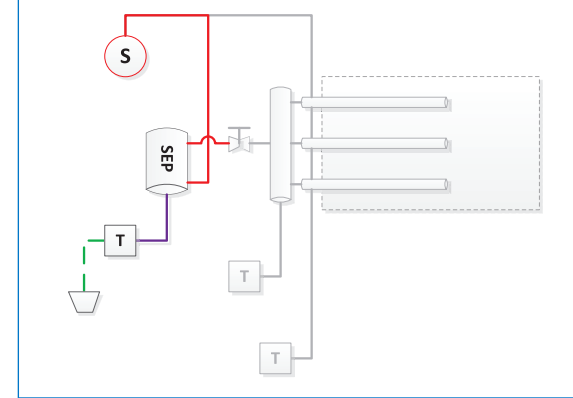

#10: Separator - to condensate main

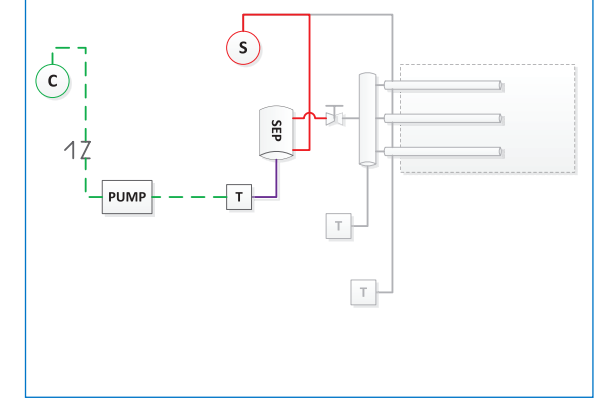

#11: Header - to drain

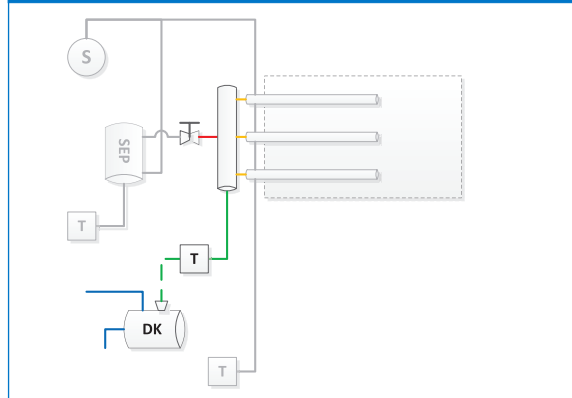

#12: Header - to condensate main

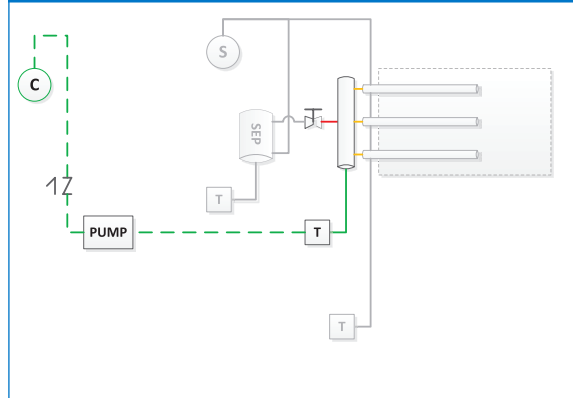

#13: Jacketing - to drain

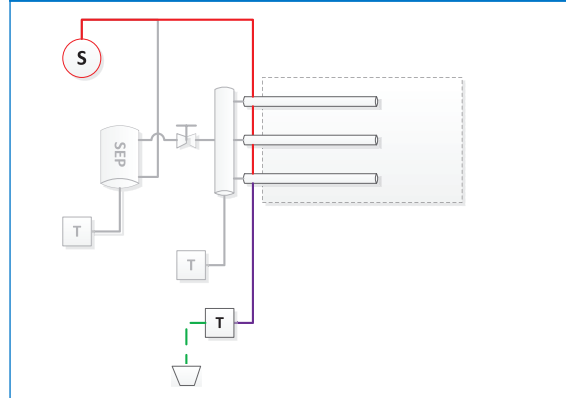

#14: Jacketing - to condensate main (pump)

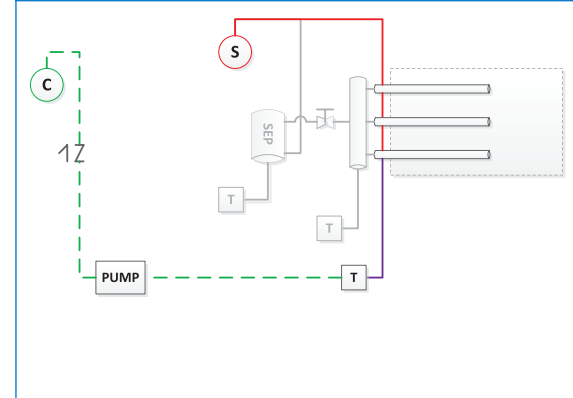

#15: Jacketing - to condensate main

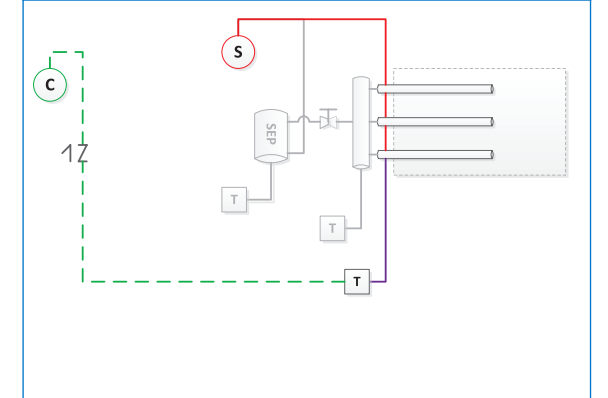

LEGEND	
	Pressurized Steam
	Pressurized Condensate
	Non Pressurized Condensate
	Cold Water

**Notes:**

1. The Drane-kooler water tempering device can be replaced with a standard drain.
2. Check with local code for maximum discharge drain temperature.
3. DriSteem recommends lifting of no more than 6 inches per psi of steam pressure.

Table 2-1: Steam trap recommendations

Standard piping	
Cast iron F&T	Steam pressure ≤ 15 PSI and not lifting condensate
Cast iron inverted bucket	Steam pressure > 15 PSI or lifting condensate
Stainless piping	
Stainless thermostatic	Steam pressure ≤ 15 PSI and not lifting condensate Up to 60 lbs/hr condensate load
Stainless F&T	Steam pressure > 15 PSI or lifting condensate Up to 120 lbs/hr condensate load
Stainless inverted bucket	Steam pressure > 15 PSI or lifting condensate



14949 Technology Drive, Eden Prairie, MN 55344  
800-328-4447 or 952-949-2415 • www.dristeem.com

**DRI-STEEM Corporation** • a subsidiary of Research Products Corporation  
DriSteem U.S. operations are ISO 9001:2015 certified

DriSteem, Ultra-sorb, Rapid-sorb, and DriCalc are registered trademarks of DRISTEEM Corporation.  
Maxi-bank is a trademark of DRISTEEM Corporation.  
DriSteem, Ultra-sorb, Rapid-sorb, and Dri-calc are filed for trademark registration in Canada and the European community.