

THE SIX STEPS OF HUMIDIFICATION DESIGN

To help you better understand the humidification process, this issue of Engineering Humidification will walk you through the basic steps of humidification system design, addressing the key variables – building construction, load, energy and water sources, placement and control – that affect system design. To design a system correctly, these variables must be considered and understood thoroughly.

System requirements may vary

Many factors must be considered when designing a building's humidification system. Each application will have a unique set of requirements that will affect system design. Even though individual applications will vary, the process to design a humidification system will be consistent from project to project.

The following six steps will help you properly design a humidification system for any application:

1. Review building construction
2. Determine humidification load
3. Select best energy source
4. Choose appropriate water source
5. Determine humidification system placement
6. Select the control system



STEP 1: REVIEW BUILDING CONSTRUCTION

When air and heat escape, so does humidity

Similar to protecting against unwanted heat loss in a building, there are a few things you can do to ensure accurate humidity control and to protect against unwanted condensation or loss of humidity. Whether working with new construction or in retrofit situations:

- Evaluate the vapor barrier qualities of the building you plan to humidify.
- Examine all areas of conditioned air loss, such as exhaust fans, open windows, and doors.
- Examine roof construction, especially steel supports, for poorly insulated areas that could result in condensation.

STEP 2: DETERMINE HUMIDIFICATION LOAD

Load is based on quantity of entering air

Properly calculating the load ensures correct and consistent humidity levels. Undersizing will result in a system that will not maintain desired relative humidity (RH); and oversizing may cause erratic humidity levels or wet ducts, filters or fans. As a general rule, the humidification load is based on the amount of air entering a building or space and the desired RH level.

How to calculate humidification load:

1. Natural ventilation method, used for buildings without a ventilation system. The load is usually calculated using the air change method.
2. Mechanical ventilation method, used for buildings with mechanical ventilation. The load is based only on the amount of air entering a building or space.
3. Economizer cycle method, used for buildings with year-round air conditioning equipped with economizer control. The load is calculated using temperatures of outside, inside, return and mixed air.

STEP 3: SELECT THE BEST BEST ENERGY SOURCE

Energy use is an important consideration

A litre of water requires approximately 0.74 kW to vaporize. When selecting a humidification system, remember that six to seven grams of water are typically required for every kilogram of outside air introduced.

Two major types of humidifiers

- Isothermal systems use heat from an external source to create humidity. Electricity, natural gas, hot water and boiler steam are isothermal heat sources used to boil water into steam for humidification.
- Adiabatic systems use heat from the surrounding air to change water into vapor for humidification (evaporation). Wetted media, high pressure, foggers and ultrasonic technologies are typical adiabatic systems.

Why choose isothermal?

- If there is an on-site boiler or hot water source, direct steam injection or a heat-exchanger-type isothermal system may be most appropriate. Consider using a steam-to-steam system to avoid direct injection of boiler chemicals (see box, right).
- Electric hot element systems easily integrate. Because of their relatively small size and ease of integration into existing systems, electric element humidification systems can be used for virtually any application.
- The economic benefits of natural gas. Gas-fired humidification systems can offer dramatic energy savings over electric systems.

When is adiabatic appropriate?

- Is the supply air warm and dry? If so, your humidification needs may be met by an adiabatic system such as a fogger, which uses sensible heat in the air for its energy source. In the right environment, these systems can be very economical due to the cooling effect they provide. Exercise caution, however, when applying to standard commercial applications with short absorption distances and low discharge air temperatures.

STEP 4: CHOOSE THE APPROPRIATE WATER SOURCE

Types of water vary

Humidification systems operate using a variety of water types:

- Potable (tap) water, directly from a city or well water source.
- Softened water, either heated or unheated.
- Reverse osmosis (RO) water, which has gone through a filtering process to remove most of the minerals, as well as some contaminants.
- Deionized (DI) water, which is generally considered to be the purest water. DI water is used where the steam must be of high quality and free of minerals and contaminants, and where uninterrupted service is required.
- Direct injection of boiler water. See box below for discussion about choices when using on-site steam.

CHOICES WHEN USING ON-SITE STEAM

Using on-site steam for humidification can be a good economic choice. Pressurized steam can be directly injected into the airstream or it can be run through a heat exchanger to heat tap, softened or DI/RO water for humidification steam (see Figure 1).

Chemically-treated boiler steam may affect indoor air quality. Many humidifier users are finding that chemically treated, boiler-generated steam is unsuitable for direct injection humidification. This is because boiler water is treated with anticorrosion chemicals that are then emitted with the steam into the occupied space. These chemicals have been found to irritate eyes and skin, and aggravate respiratory disorders such as asthma. In addition, they can accelerate the aging process of certain materials like paper and wood, an issue especially relevant to museums.

In your design, consider a closed loop humidification system (such as steam-to-steam) to prevent the discharge of chemically-treated steam into your building.

Figure 1: Steam-to-steam evaporative humidifier

Principle of operation:

1. Makeup water enters the evaporating chamber through the automatic water makeup valve.
2. Pressurized steam passes through the modulating steam valve to the heat exchanger. Here it causes water in the chamber to boil creating secondary, evaporative steam for humidification.
3. Condensate from the heat exchanger passes through a steam trap and is returned to the boiler.
4. Humidification steam is dispersed into the airstream.

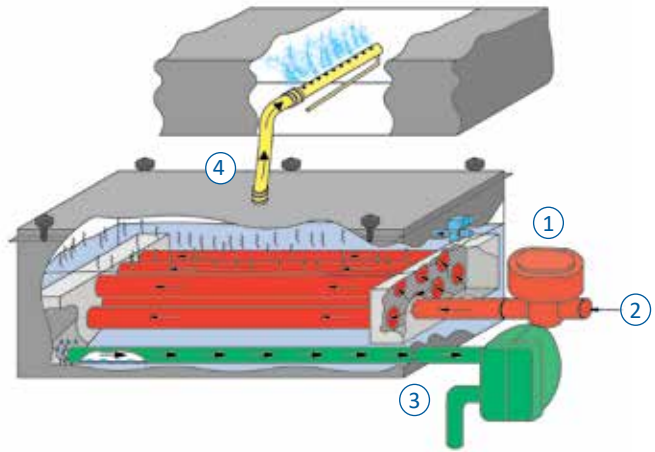

Water type affects performance

- Mineral concentration in the supply water directly relates to the amount of maintenance and cleaning your humidification system requires. The higher the mineral concentration, the more downtime required for cleaning. Environments that require a system to be continuously online should use demineralized (DI or RO) water. Systems using softened water can operate several seasons without the need for cleaning (regular inspections are recommended).

STEP 5: DETERMINE HUMIDIFIER PLACEMENT

The humidification system generally consists of a vapor or steam humidifier and a dispersion assembly. The proper placement of these two components is crucial to the operating success of the humidification process. Usually, there is no single “right” placement for a humidifier. Much depends on the system design, its uses, and its applications. However, the following paragraphs and dispersion assembly placement examples are presented as guidelines for common situations.

First, check available absorption distance

Available absorption distance will affect system choice. Dispersed steam must be absorbed into the airflow

before it comes in contact with any duct elbows, fans, vanes, reducer, filters, or any object that may cause condensation and dripping. Not all humidification systems guarantee absorption within a short distance, so it is important to be aware of the available absorption distance early in your design process. (See box below)

Placement of adiabatic units

Adiabatic units need to be positioned in an AHU system where sufficient heat is available to vaporize the water being added. In most systems, this is downstream of the heating coil and upstream of the cooling coil. This allows the air to be preheated as needed. Typically, adiabatic units require an AHU extension.

FACTORS THAT AFFECT ABSORPTION

1. *Mixing of air and steam. Uneven airflow across a dispersion unit may result in non-uniform mixing of steam with air, affecting absorption distance.*
2. *ΔRH (the difference between entering and leaving RH). As Δ increases, more humidity needs to be dispersed into the air, and thus the absorption distance increases.*
3. *Duct temperature. Cool air absorbs less than warm air and will require longer absorption distances.*

Figure 2: Placing a dispersion assembly in an AHU

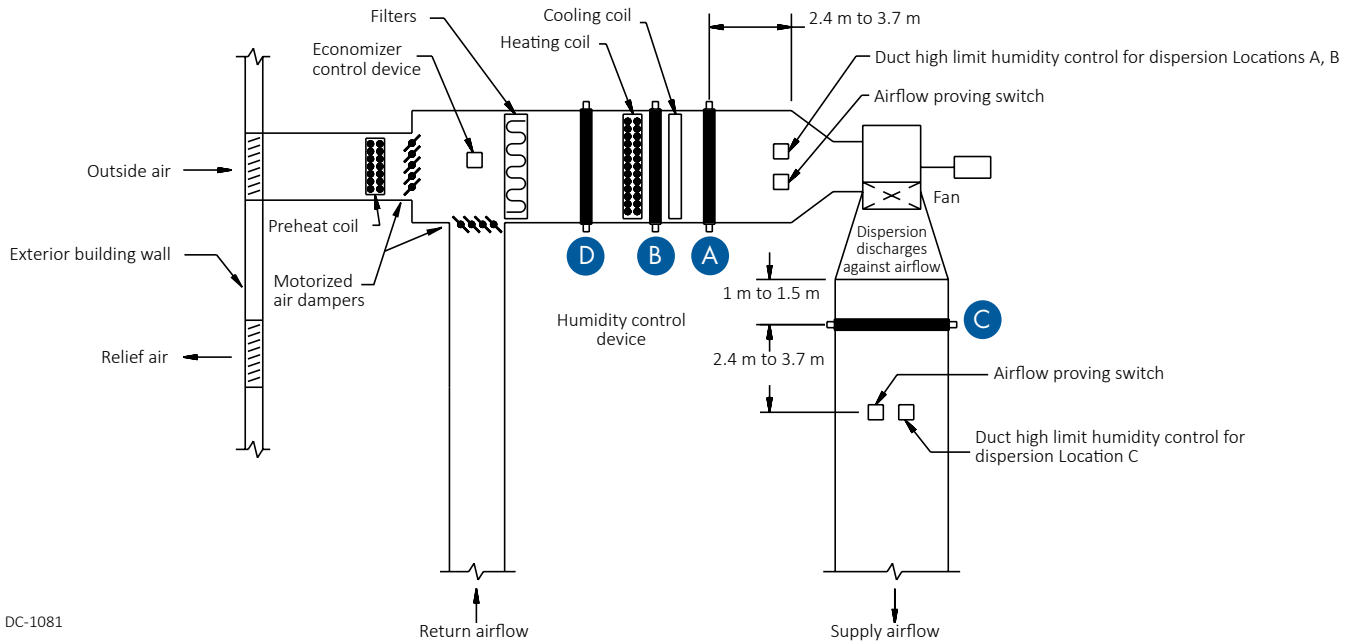

Placing a dispersion assembly in an AHU (see Figure 2)

- Location **A** is the best choice. Installing downstream of heating and cooling coils provides laminar flow through the dispersion unit, plus, the heated air provides an environment for best absorption. Use a multiple tube dispersion unit to ensure complete absorption of steam vapor before fan entry.
- Location **B** is the second-best choice. However, in change-over periods, the cooling coil may eliminate some moisture for humidification.
- Location **C** is the third-best choice. Air leaving a fan is usually very turbulent and may cause vapor to not absorb at the expected absorption distance. Allow for more absorption distance if installing downstream of a fan.
- Location **D** is the poorest choice. The cooler air at this location will require an increased absorption distance.

Duct placement near an elbow (see Figure 3)

- Location **A** is the best choice. Better absorption will occur on the downstream side of an elbow than on the upstream side.
- Location **B** is the second-best choice. Installing upstream of an elbow may cause wetting at the turning vanes. In

- cases where it is structurally impossible to avoid Location B, use a multiple tube dispersion unit to ensure complete absorption. Also, since more air flows along the outside “ of a turn, better absorption will occur if the humidifier discharges proportionately more steam in that part of the airstream.
- At both locations, discharging steam against or perpendicular to the airstream gives slightly better mixing and absorption than discharging with the airstream.

Figure 3: Placing a dispersion assembly near an elbow

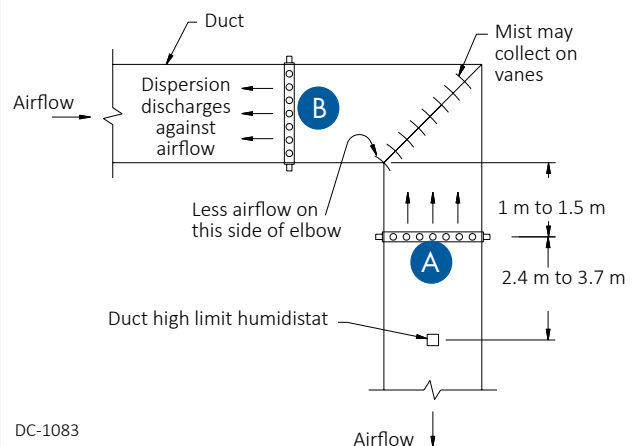

Placement in a primary/secondary system (see Figure 4)

This type of system is commonly applied to hospitals with multiple surgery rooms served by a single air handler but with individual humidity control required for each surgery room. Placement of the primary humidification system is within the main air handling unit serving the general hospital areas to a design of 21 °C and 40% RH. The secondary humidification system would be located close to the point of steam discharge into the critical care areas requiring individual humidity control.

STEP 6: SELECT THE CONTROL SYSTEM

A wide range of relative humidity control ($\pm 1\%$ to $\pm 5\%$ RH) is achievable with today's control technology; however, note that humidity control rests not only with the controls, but with the complete building system. Individual building dynamics, as mentioned in Step 1 and 4, can affect the accuracy and control of any humidification system.

Factors to consider when selecting humidity control

- Desired relative humidity set-point. Typical RH ranges are:
 - Comfort, static control: 35% to 60% RH

- Paper storage, printing: 40% to 50% RH
- Semiconductor manufacturing: 35% to 55% RH
- Health medical facilities: 35% to 75% RH

- Acceptable RH fluctuation. What is the acceptable variance from the desired RH set-point?
- Space temperature. Stable temperatures need to be maintained to accurately control humidity.
- Component quality. The control system is only as good as the least accurate component in the system. Many system difficulties can be eliminated by selecting humidity controls that match the application.

Sensor and transmitter locations are critical (see Figure 5)

Sensor or transmitter location has a significant impact on humidifier performance. In most cases, we recommend that you do not interchange duct and room humidity devices. Room humidity devices are calibrated with zero or little airflow, whereas duct humidity devices require air passing across them. Recommended sensor locations:

- A** This is the ideal sensing location because this placement ensures the best uniform mix of dry and moist air with stable temperature control.
- B** This location is acceptable, but the room environment may affect controllability, such as when the sensor is too close to air grilles, registers or heat radiation from room lighting.

Figure 4: Placement in a primary/secondary system

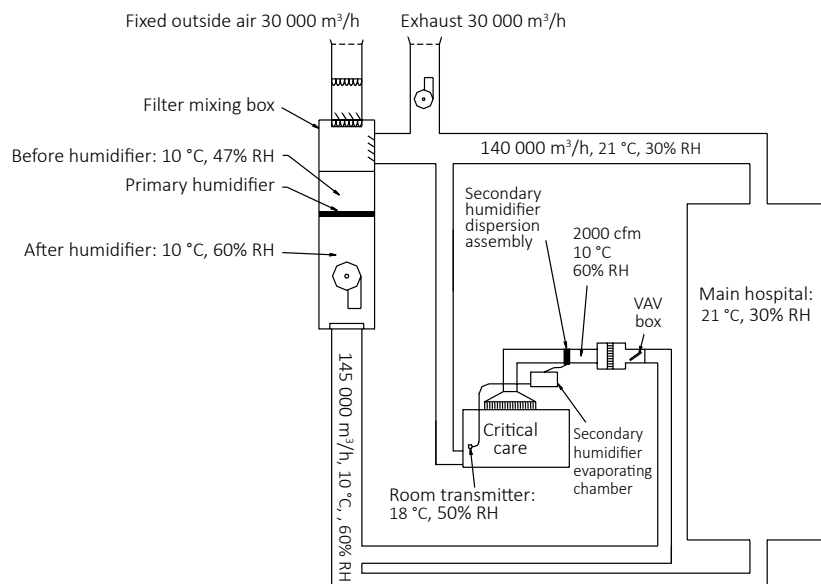

OM-784-2

- C** This location is acceptable because it provides a good uniform mixture of dry and moist air, but if an extended time lag exists between moisture generation and sensing, make sure the control contractor extends the sampling time.
- D** This location behind a wall or partition is acceptable for sampling the entire room if the sensor is near an air exhaust return outlet. This location is also typical of sensor placement for sampling a critical area.
- E** These locations are not acceptable because they may not represent actual overall conditions in the space.
- F** These locations are not acceptable. Do not place sensors near windows, door passageways or areas of stagnant airflow.
- G** This is the best location for a duct high limit humidistat or humidity sensor.

- A VAV control package is used with variable air volume systems, which require a higher level of control than a constant air volume system. Changing air flow quantities, and the cooler supply air found in most VAV systems, require the use of both space- and duct-mounted humidity controls used in conjunction with a programmable logic controller, which modulates the output of the humidifier.
- An air flow proving switch will disengage humidifier operation if the fan stops.
- Cold-snap offset. Senses window temperature and temporarily lowers indoor RH to prevent condensation on the inside of windows when the outdoor temperature drops.

Additional considerations

- A high-limit humidistat ensures that the RH does not exceed its set-point up to a maximum of 90% RH. It must be located past the point of steam absorption, which will vary depending on the dispersion device chosen.

EASY AS 1-2-3-4-5-6!

We hope this document has helped you understand the six steps of humidification design. Just remember that while a particular humidification application will have many unique variables, the humidification design process, no matter how many variables, always follows the same six steps. And also know that your DriSteem representative will be there to guide you and answer any questions you might have about humidification system design.

Figure 5: Recommended sensor locations

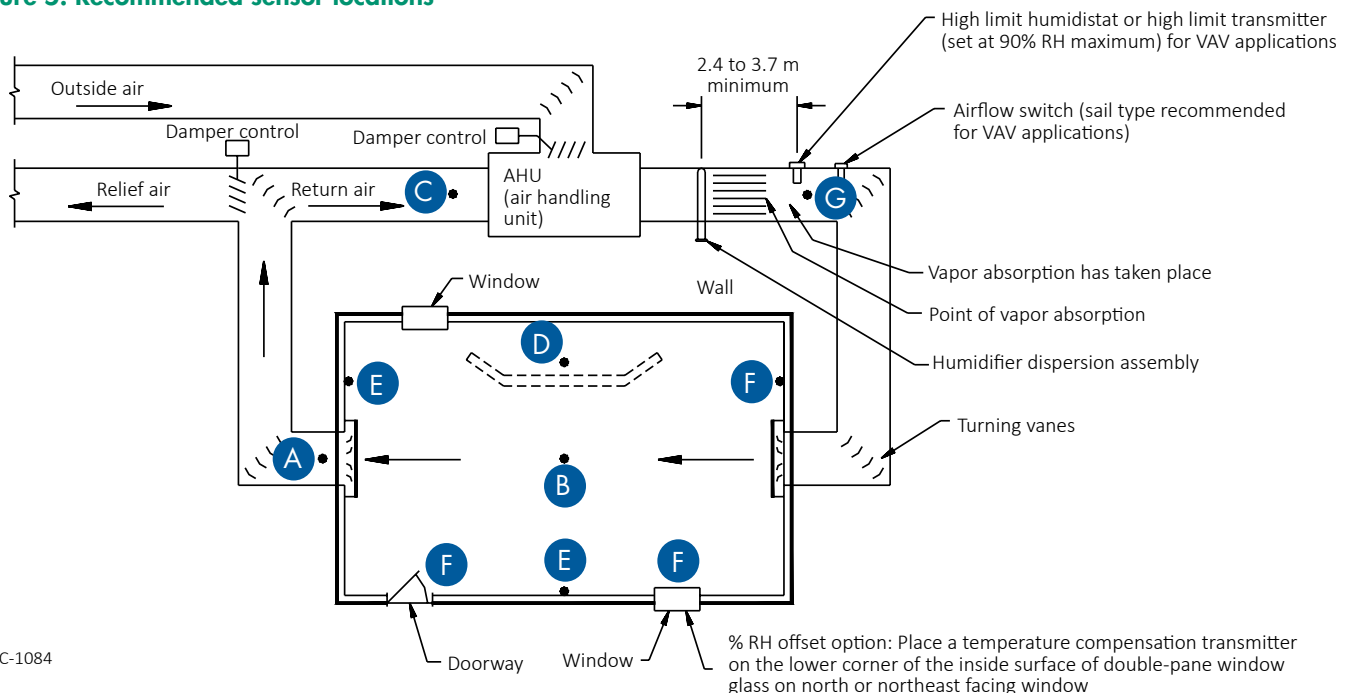

DC-1084

DRISTEEM SOLUTIONS FOR ANY ENVIRONMENT

Product	Maximum capacity		Key features
PRESSURIZED STEAM			
Steam Injection	1,808 kg/h		<ul style="list-style-type: none"> • Wide capacity range • Economical to operate
Ultra-sorb® Steam Dispersion Panel	1,234 kg/h		<ul style="list-style-type: none"> • Shortest absorption available • No unnecessary heat gain • Lower installation cost
STS® Humidifier	726 kg/h		<ul style="list-style-type: none"> • Economical clean steam • Uses plant steam to produce chemical-free humidification steam
GAS			
GTS® Humidifier	272 kg/h		<ul style="list-style-type: none"> • Lowest energy costs • Ideal choice for larger systems with high humidification demands
ELECTRIC			
RTS® Humidifier	147 kg/h		<ul style="list-style-type: none"> • Sustained quality and dependability • Elegant cabinet-style humidifier that is compatible with all water types.
Vaporstream® Humidifier	129 kg/h		<ul style="list-style-type: none"> • Industrial-grade • Meets the humidification demands of any building to ±1% accuracy
Humidi-tech® Humidifier	46 kg/h		<ul style="list-style-type: none"> • Compact cabinet-style • Reliable, consistent humidification in a complete package
CRUV® Humidifier	46 kg/h		<ul style="list-style-type: none"> • Compact • Can be mounted inside an existing system, including packaged AC units
XT Series Humidifier	130 kg/h		<ul style="list-style-type: none"> • Easy installation, wide range of models • Maintenance is a simple cylinder replacement

REDUCE ENERGY COSTS WITH THE GTS® HUMIDIFIER



Save with gas!

The GTS (gas-to-steam) humidifier offers precise humidity control for a fraction of the operating cost of an electric humidifier. Consider these benefits:

- Steam output rangeability of up to 40 to 1 closely tracks humidity set point
- Easy-to-use Vapor-logic® controller
- Capacity to 272 kg/h; link multiple units for increased capacity
- Robust outdoor enclosure option protects in cold and hot climates

VISIT THE ON-LINE HUMIDIFICATION RESOURCE CENTER

Check out our web site to learn more about properly applying humidification systems, types of humidifiers on the market today, and current humidification issues.

You'll also find information on **DriCalc**® — DriSteem's exclusive software that sizes loads, selects equipment, writes specifications, and creates equipment schedules for DriSteem products.

www.dristeem.com



DRI-STEEM Corporation

DriSteem U.S. operations are ISO 9001:2015 certified

U.S. Headquarters:
14949 Technology Drive
Eden Prairie, MN 55344
800-328-4447 or 952-949-2415
952-229-3200 (fax)

European office:
Marc Briers
Grote Hellekensstraat 54 b
B-3520 Zonhoven
Belgium
+3211823595 (voice)
+3211817948 (fax)
E-mail: marc.briers@dristeem.com

Continuous product improvement is a policy of DriSteem Corporation; therefore, product features and specifications are subject to change without notice.

DriSteem, DriCalc, Rapid-sorb, Ultra-sorb, Vapor-logic, RTS, GTS, and Humidi-tech are registered trademarks of Research Products Corporation and are filed for trademark registration in Canada and the European community.

Drane-kooler is a trademark of DriSteem Corporation.

Product and corporate names used in this document may be trademarks or registered trademarks. They are used for explanation only without intent to infringe.

© 2021 Research Products Corporation



Form No. EH-SIXSTEPS-M-0721