



Avoid wet ducts

by ensuring humidification absorption.

A humidification system is a natural fit to your HVAC system to help create a healthy environment, improve occupancy comfort, reduce static electricity and preserve processes and materials. One of the most important factors of proper humidification is absorption. Whether steam (isothermal humidification) or unheated water droplets (adiabatic humidification) are being introduced into the air, incomplete absorption causes poor control and wet ducts, which can result in microbial growth, rusting or dripping into finished spaces. But with a basic understanding of the factors that affect absorption, you can enjoy all the benefits of humidification without worrying about wet ducts.

HUMIDIFICATION BASICS

1. To convert a pound of water into vapor requires about 1000 Btus. This can be accomplished isothermally or adiabatically. Isothermal humidification systems use heat from an external source, such as electricity, natural gas or boiler steam, to convert water to vapor. Adiabatic humidification systems use heat from the surrounding air to convert water into vapor for humidification.
2. Isothermal systems disperse pressurized steam into the air directly from a boiler or unfired steam generator, or nonpressurized steam from a vapor generator (evaporative humidifier). Adiabatic systems disperse mist or fog into the air using pressurized water and/or pressurized air, or water evaporated from a wetted media.
3. Both isothermal and adiabatic systems disperse directly into ducts, air handlers or open spaces (called area-type systems).
4. Absorption distance is the dimension from the leaving side of the dispersion assembly to the point where wetting will not occur. Solid objects such as coils, dampers or fans beyond this dimension will remain dry, unless they are cooler than the duct air (or space air for area-type systems).

Absorption distance is the dimension from the leaving side of the dispersion assembly to the point where wetting will not occur.

IT'S ALL RELATIVE

The amount of moisture air can hold correlates directly to air temperature. For example, a pound of air (at sea level) at 55°F containing 20 grains of moisture per pound of dry air has a relative humidity (RH) of 31%. That same pound of air at 75°F also containing 20 grains of moisture has a relative humidity of 15%, meaning that the air is at 15% of its theoretical capacity to hold moisture. In practice, once air reaches 90% relative humidity, absorption in a typical application becomes unpredictable.

When RH reaches 100%, the air is saturated, it has reached its dew point and condensation occurs. Condensation can also occur when moist air comes in contact with objects cooler than the airstream such as cooling coils, turning vanes, elbows or filters, or even the dispersion assembly. Direct steam injection assemblies typically run steam through jackets surrounding the dispersion tubes to preheat the tube and eliminate condensation. Dispersion tube orifice material is often made from a temperature-neutral material such as resin to allow steam to pass through to the air without touching metal. Much effort in humidification system design is focused on condensation, because it causes dripping and wet ducts.

Just as important as temperature is the amount of moisture to disperse (ΔRH or the difference between entering and leaving RH). The more vapor you need to add, the more volume of air you'll need for absorption to occur. In a duct or air handler, this means a longer required absorption distance or warmer air.

FACTORS THAT AFFECT ABSORPTION

The smaller the water droplet size the more quickly it will be absorbed. Steam droplets are the smallest, followed by foggers and atomizers. Droplet size is especially relevant to adiabatic humidification, for you may only have the time it takes for a drop of water to fall to the floor for absorption to occur. And if there is no airflow, such as in an area-type application, you have even less time for absorption to occur.

To ensure absorption in a duct or air handler, take advantage of the full airflow by spreading the humidification load among numerous discharge points rather than just a few. For example, Figure 1 shows two different ways to disperse steam into an airstream. Of the examples shown, the single tube dispersion device covers the smallest percentage of the airstream and has the longest absorption distance. Under the same conditions, the multiple tube dispersion assembly achieves absorption distance because it has more tubes dispersing the same amount of moisture into the airstream, and steam is therefore more evenly distributed. This causes a rapid homogenization of the steam/air mixture, which results in faster re-evaporation or second change of state.

Direct steam injection assemblies typically run steam through jackets surrounding the dispersion tubes to preheat the tube and eliminate condensation.

FIGURE 1

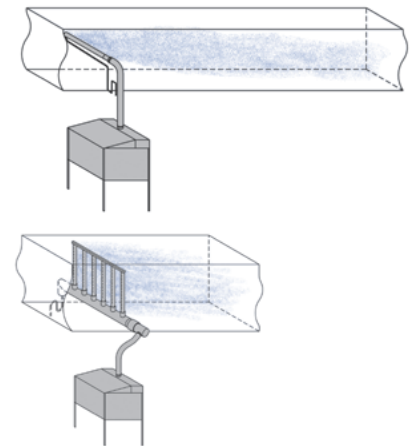

The fog shows the distance required for absorption to occur. More tubes and discharge points decrease absorption distance.

SIZE DISPERSION ASSEMBLIES FOR MAXIMUM LOAD

If a dispersion assembly is undersized for the load, steam velocity will push condensate out with the steam, causing dripping. A dispersion assembly that has both multiple dispersion tubes and discharge points on both sides of each tube fully maximizes air and steam mixing to achieve the shortest absorption distances (see Figure 2). In addition, this assembly can accommodate large humidification loads because of the dual-header design. Steam enters the top header and condensate leaves by the bottom header. By understanding the basic factors that affect absorption, you're not only understanding the most critical issues affecting proper humidification, but you're avoiding wet ducts that can cause microbial growth.

STEAM HUMIDIFICATION WITH GUARANTEED ABSORPTION

Ultra-sorb® dispersion panels from DriSteem provide rapid, drip-free steam absorption – allowing the panels to be installed within inches of downstream devices without condensation worries. When properly installed, there is no worry of standing water, microbial growth in ducts or condensed steam dripping through ducts.

Ultra-sorb panels can be installed in ducts or in air handling units. They can operate off boiler steam or steam from an evaporative humidifier.

To learn more about Ultra-sorb dispersion panels and DriSteem humidification systems, or to find your local DriSteem representative, visit www.drirsteem.com or call 800-328-4447.

DRI-STEEM Corporation

a subsidiary of Research Products Corporation
DriSteem U.S. operations are ISO 9001:2015 certified

U.S. Headquarters:
14949 Technology Drive
Eden Prairie, MN 55344
800-328-4447 or 952-949-2415
952-229-3200 (fax)

European office:
Grote Hellekensstraat 54 b
B-3520 Zonhoven
Belgium
+3211823595
drirsteem-europe@drirsteem.com

www.drirsteem.com
© 2016 Research Products Corporation
Form No. AvoidWetDucts-EN-0616

FIGURE 2

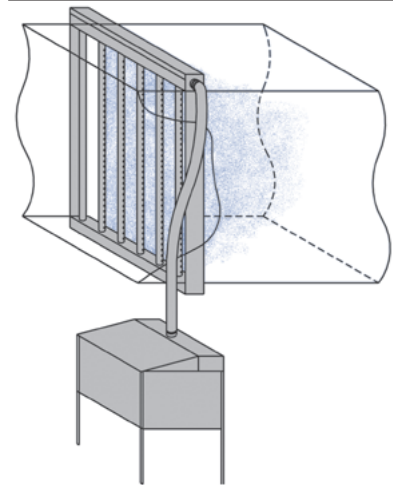

Multiple tubes and two rows of discharge points on each tube shorten absorption distance. A dual-header design allows high capacity.

FIGURE 3

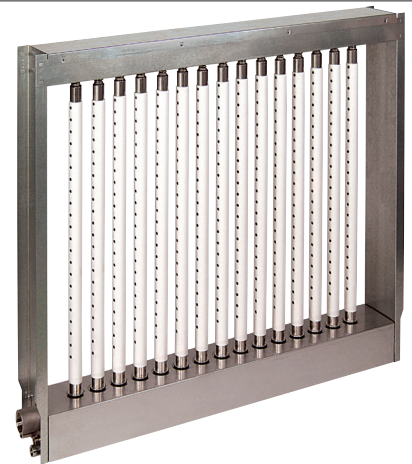

Ultra-sorb dispersion panels are designed to have the maximum number of dispersion tubes and discharge points possible without restricting airflow - creating the shortest absorption distances.