

Evair™ Dehumidifier RL Series

DEHUMIDIFIER

DriSteeM dehumidifiers, RL series are designed to dehumidify air coming into the unit by passing the incoming air over an evaporator coil to drop the air temperature below the dew point of the air. Moisture is removed from the air and drained out of the unit to a common floor or waste drain. The air is then reheated in the condenser coil and exits the unit. Dehumidification occurs until the set point is reached, then shuts off until the control determines a need for operation.

FIGURE 1-1: DEHUMIDIFIER CONTROL

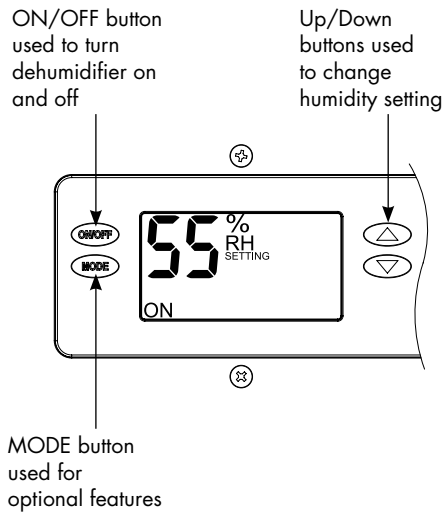

FIGURE 1-2: MODEL RL-3 DEHUMIDIFIER

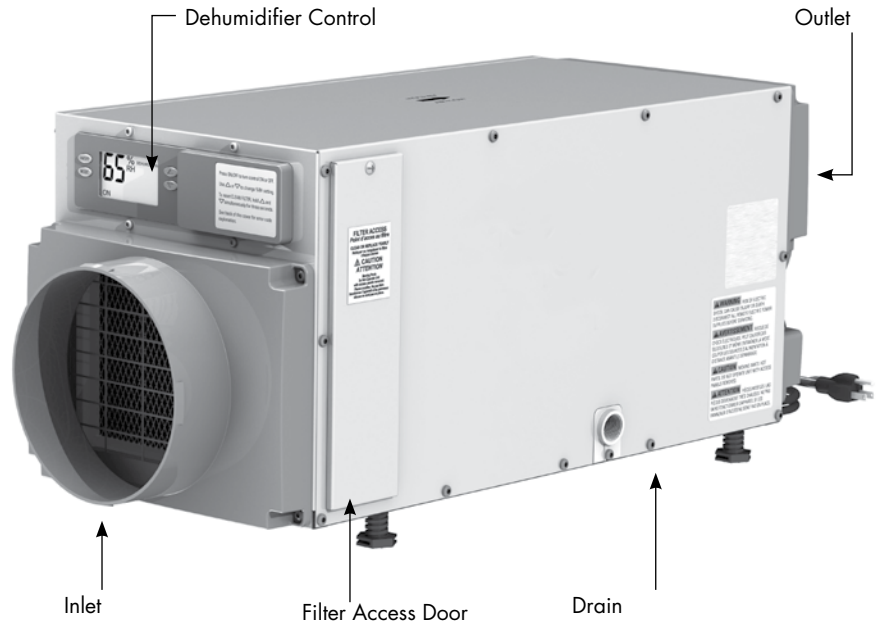
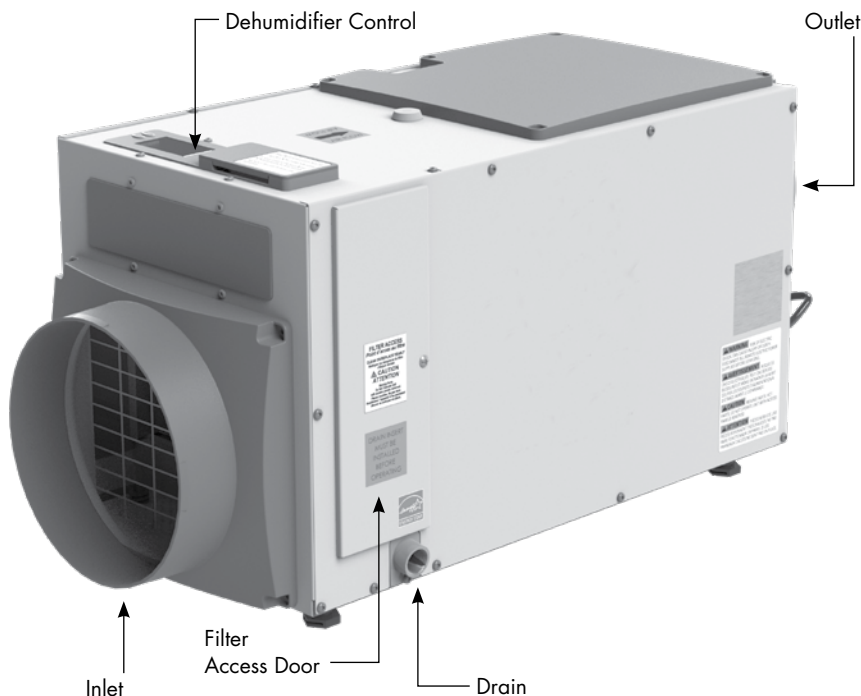
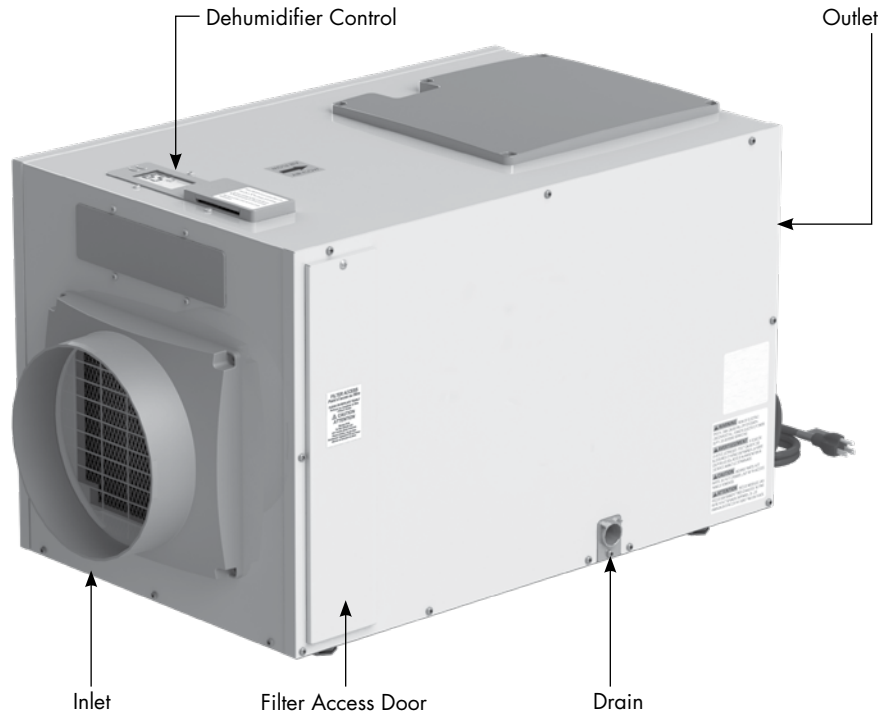

FIGURE 1-3: MODEL RL-4 DEHUMIDIFIER



Dehumidifier RL Series

FIGURE 2-1: MODEL RL-6 DEHUMIDIFIER



RL-6 angle

FIGURE 2-2: MODEL RL-9 DEHUMIDIFIER

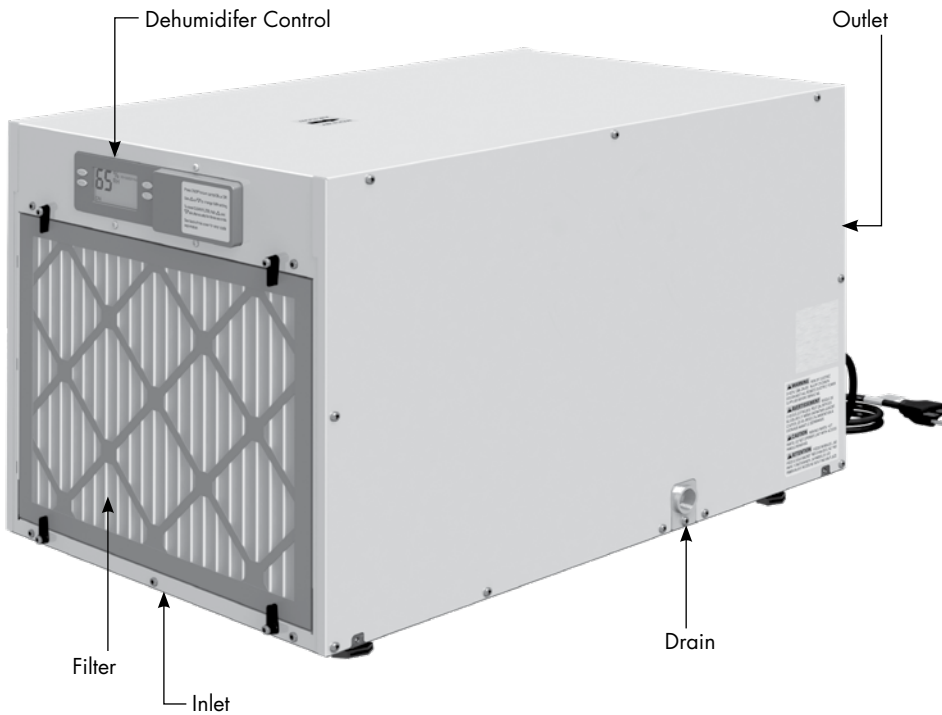

90-2393

Dehumidifier RL Series

FIGURE 3-1: MODEL RL-14 DEHUMIDIFIER

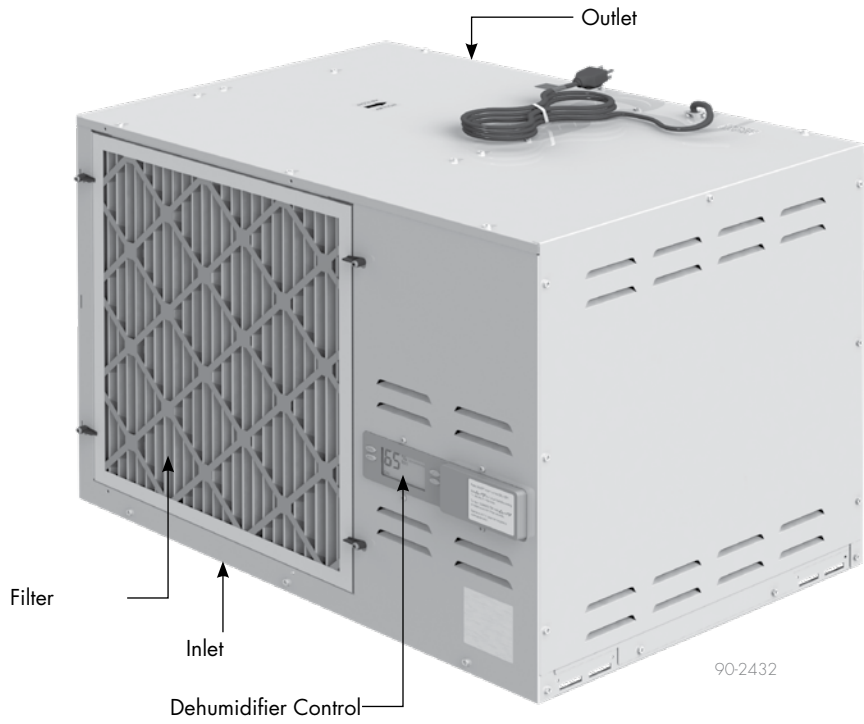
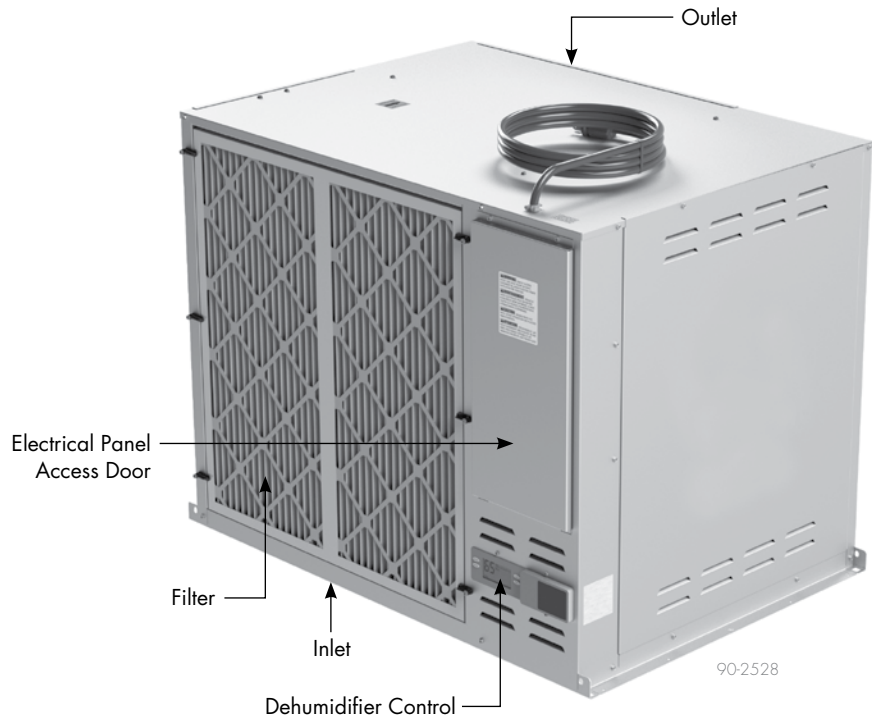

FIGURE 3-2: MODEL RL-31 DEHUMIDIFIER



Models, capacities, and electrical specifications

**Table 4-1:
RL Series Specifications**

	Model RL-3	Model RL-4	Model RL-6	Model RL-9	Model RL-14		Model RL-31	
Capacity ⁽¹⁾	70 pints/day (3 lb/hour)	100 pints/day (4 lb/hour)	130 pints/day (6 lb/hour)	210 pints/day (9 lb/hour)	320 pints/day (14 lb/hour)	340 pints/day (15 lb/hour)	710 pints/day (31 lb/hour)	
Voltage	120 VAC, 1 Phase, 60 HZ	120 VAC, 1 Phase, 60 HZ	120 VAC, 1 Phase, 60 HZ	208-240 VAC, 1 Phase, 60 HZ	208-240 VAC, 1Phase, 60 HZ	277 VAC, 1Phase, 60 HZ	208-240 VAC, 1 Phase, 60 HZ	277 VAC, 1Phase, 60 HZ
Operating Current ⁽¹⁾	5.8A 115 VAC	6.9A 115 VAC	8.3A 115 VAC	8.6A 240 VAC	11.1A 240 VAC	9.2A 277 VAC	19.6A 240 VAC	17.4A 277 VAC
Rated Current	-	-	-	-	20 amp breaker		24A (install on dedicated 30A circuit)	
Efficiency ⁽¹⁾	2.1 L/kWh (4.4 pints/ kWh)	2.6 L/kWh (5.5 pints/ kWh)	2.8 L/kWh (5.9 pints/ kWh)	2.9 L/kWh (6.1 pints/ kWh)	2.9 L/kWh (6.1 pints/ kWh)	2.5 L/kWh (5.3 pints/ kWh)	3.0 L/kWh (6.3 pints/kWh)	
Recommended Breaker Size	15A	15A	15A	15A	20A	20A	30A	30A
Recommended Wire Gauge	14 AWG, Copper	14 AWG, Copper	14 AWG, Copper	14 AWG, Copper	12 AWG, Copper	12 AWG, Copper	10 AWG, Copper	10 AWG, Copper
Maximum Fuse or Breaker Size (MOC)	-	-	-	19A	30A or lower	25A or lower	40A at 208V 35A at 240V	30A
Minimum Circuit Ampacity (MCA)	-	-	-	11A	21.9A at 208V	18.5A	28A at 208V 25A at 240V	21A
Operating Temperature Range	50°F to 104°F (10°C to 40°C), 60°F/40% RH to 85°F/80% RH (15.6°C/40% RH to 25.9°C/80% RH) (ideal conditions for unit to not go into defrost or shut down due to high pressure)							
Operating Dew Point Lower Limit	40°F (4°C)						36°F (2°C)	
Operating Weight	56 lbs (25 kg)	64 lbs (29 kg)	98 lbs (45 kg)	85 lbs (39 kg)	180 lbs (82 kg)		360 lbs (163 kg)	
Shipping Weight	84 lbs (38 kg)	87 lbs (40 kg)	129 lbs (59 kg)	118 lbs (54 kg)	214 lbs (97 kg)		385 lbs (175 kg)	
Drain Size	3/4" FNPT							
Filter (MERV 11)	8" x 11.75" x 1"	11.88" x 13.5" x 1"	14" x 19" x 1"	14" x 18" x 2"	20"x22"x2"		30" x 32" x 2"	
Airflow @0.0" ESP	200 CFM (340 m ³ /h)	280 CFM (476 m ³ /h)	310 CFM (527 m ³ /h)	525 CFM (892 m ³ /h)	830 CFM (1410 m ³ /h)		1760 CFM (2990 m ³ /h)	
Power cord	Units shipped with 8' (2.43 m) power cord			Units shipped with 10' (3.05 m) power cord or can be hard wired.				
Dehumidifier control	50°F and 104°F (10°C to 40°C) cut off							
External control	On/off dry contact							
⁽¹⁾ Rated capacity and energy factor test done and current draw measured in accordance with AHAM DH-1 2008 at 80°F (26.7°C), 60% RH inlet air at 0.0 ESP.								

Specifications

**Table 5-1:
RL Series Specifications**

	Model RL-3	Model RL-4	Model RL-6	Model RL-9	Model RL-14	Model RL-31
Duct Kit	Included			Optional		
Feet	Attached				Optional	
Hanging Kit	Optional			Included		Built-in
Drain Trap	-				Included	
Air Discharge	End	Top or end		End		
Onboard Controller	Front	Field-interchangeable from top to front		Front		
D77 Controller	Optional					
BACnet Humidistat (Room) Controller	Optional					
BACnet Humidistat (Duct) Controller	Optional					

FIGURE 5-1: SPACE CLEARANCES (ALL MODELS)

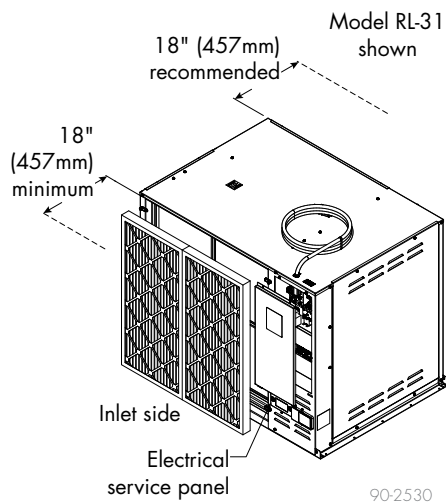

Dimensions

FIGURE 6-1: MODEL RL-3 DEHUMIDIFIER DIMENSIONS

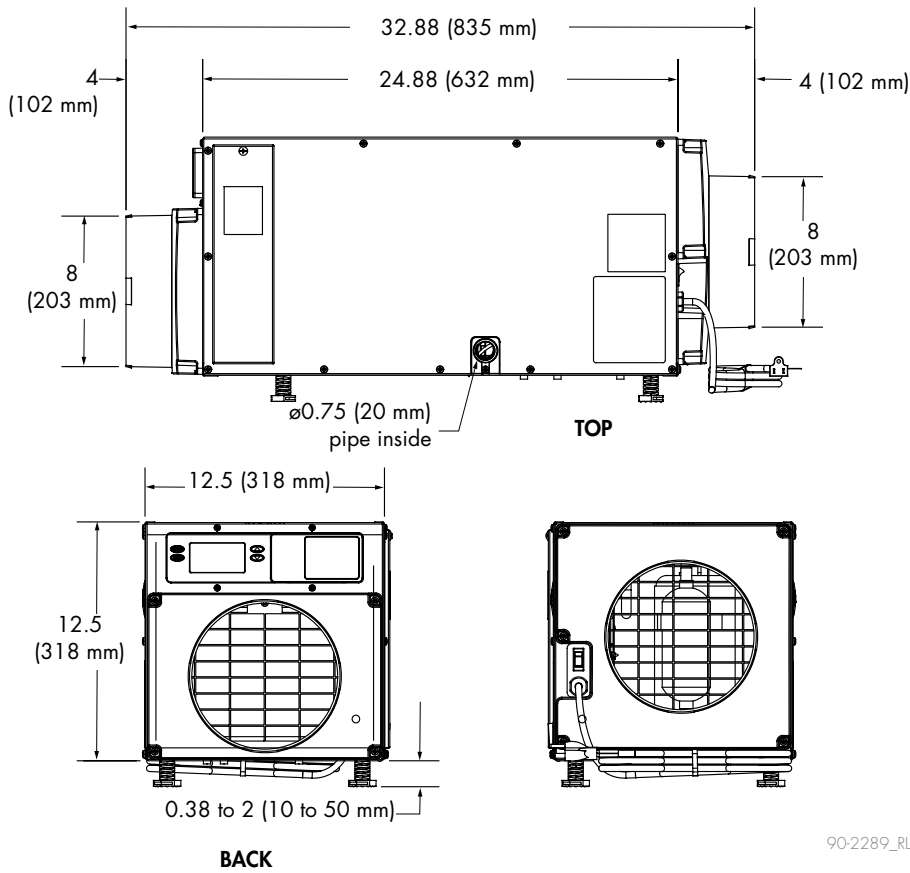
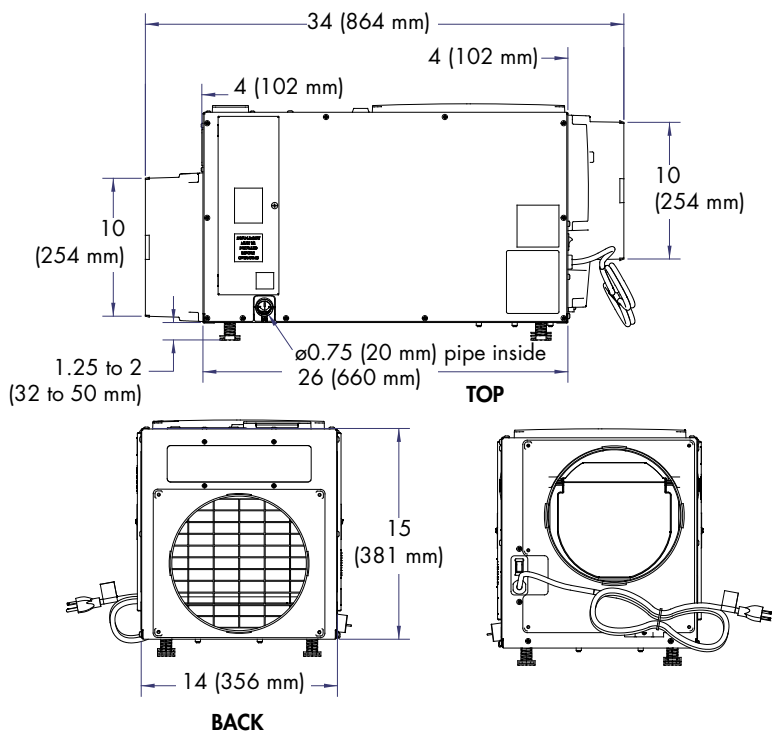
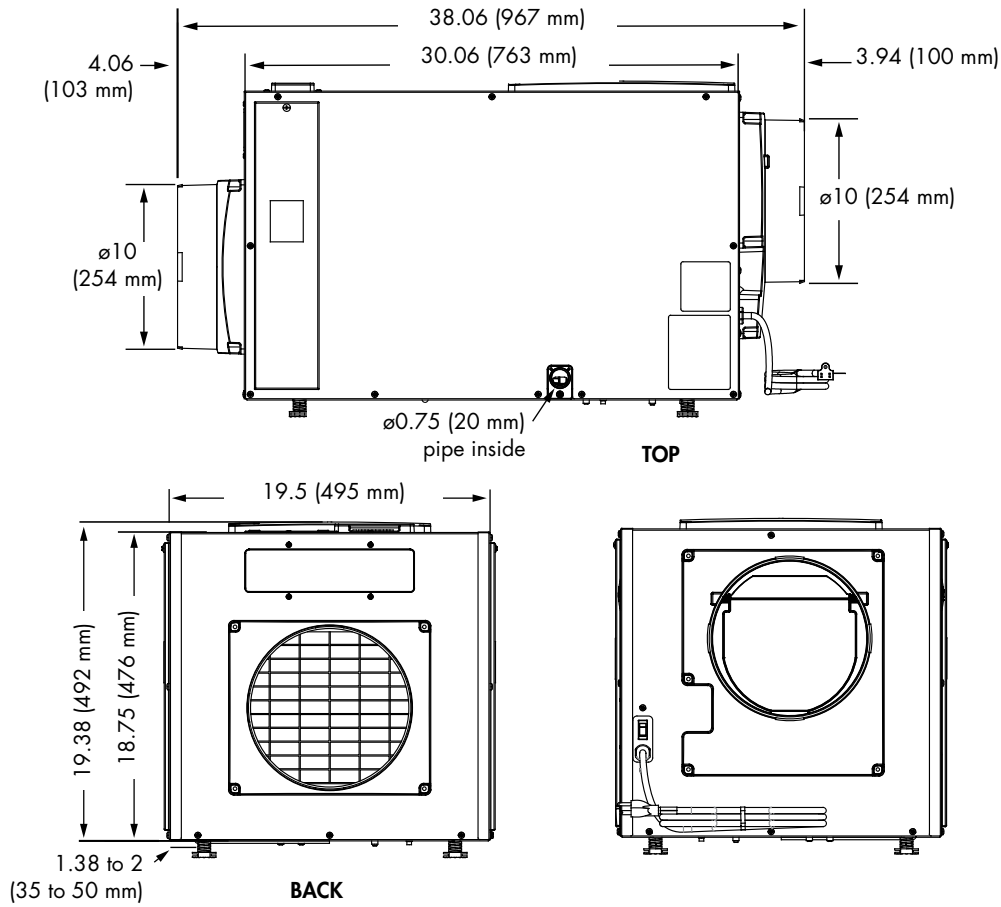

FIGURE 6-2: MODEL RL-4 DEHUMIDIFIER DIMENSIONS



Dimensions

FIGURE 7-1: MODEL RL-6 DEHUMIDIFIER DIMENSIONS



90-2053

FIGURE 7-2: MODEL RL-9 DEHUMIDIFIER DIMENSIONS

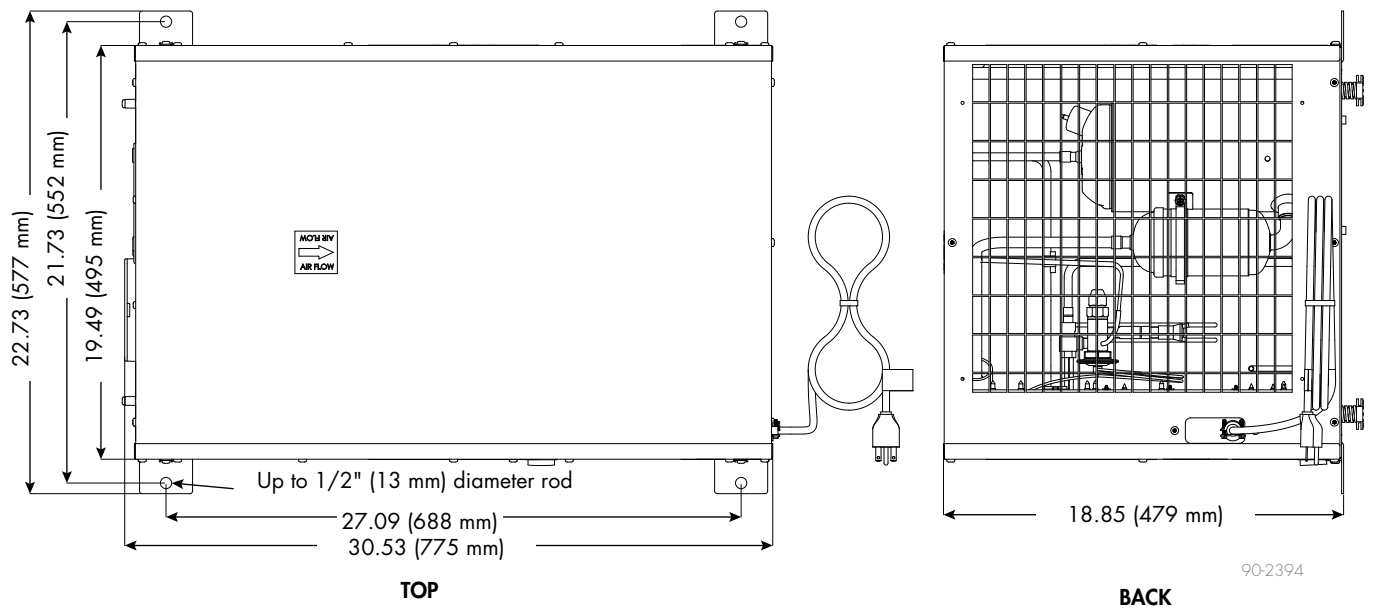

90-2394

Dimensions

FIGURE 8-1: MODEL RL-14 DEHUMIDIFIER DIMENSIONS

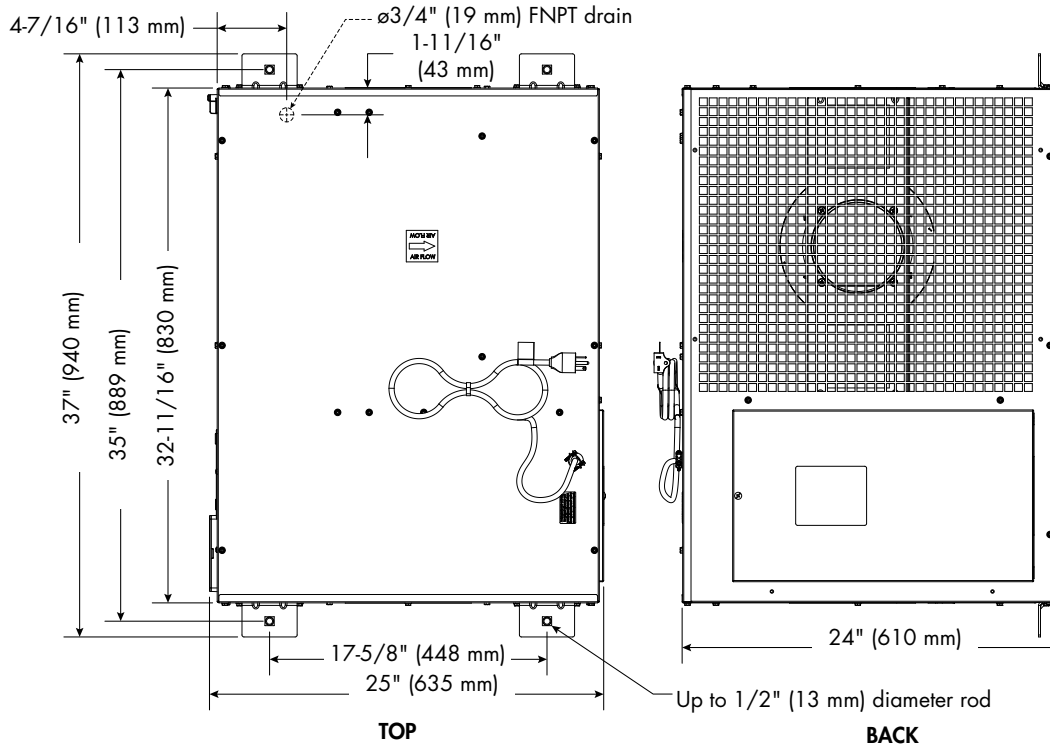

90-2433

FIGURE 8-2: MODEL RL-31 DEHUMIDIFIER DIMENSIONS

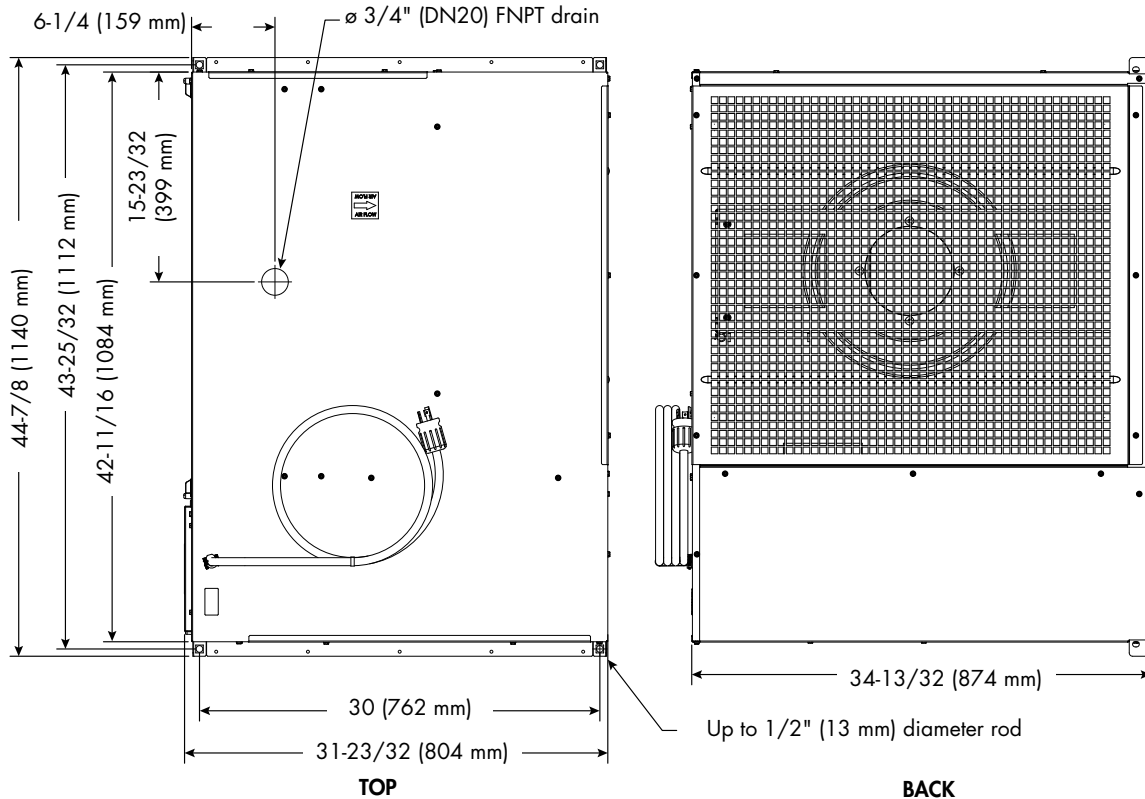

90-2529

Model RL-3 and RL-4 Dehumidifier Performance Data

Table 9-1:
Model RL-3 Water Removal Capacity in Pounds per Hour (lb/h)

Temperature dry bulb °F (°C)	% Relative Humidity					
	50	55	60	65	70	75
80 (27)	2	3	3	3	4	4
75 (24)	2	2	3	3	3	3
70 (21)	2	2	2	3	3	3
65 (18)	2	2	2	2	2	3
60 (16)	-	-	-	-	2	2

Rating capacity measured in accordance with AHAM DH-1 2008 at 80°F (26.7°C), 60% RH inlet air at 0.0 ESP.

Table 9-3:
Model RL-4 Water Removal Capacity in Pounds per Hour (lb/h)

Temperature dry bulb °F (°C)	% Relative Humidity					
	50	55	60	65	70	75
80 (27)	3	4	4	5	5	6
75 (24)	3	3	4	4	5	5
70 (21)	2	3	3	4	4	4
65 (18)	2	2	3	3	3	4
60 (16)	-	-	-	-	2	3

Rating capacity measured in accordance with AHAM DH-1 2008 at 80°F (26.7°C), 60% RH inlet air at 0.0 ESP.

Table 9-2:
Model RL-3 Heat Discharged into Room Space per Hour of Operation (BTU/h)

Temperature dry bulb °F (°C)	% Relative Humidity					
	50	55	60	65	70	75
80 (27)	4400	4900	5300	5500	6000	6200
75 (24)	4200	4700	4900	5300	5500	5700
70 (21)	4000	4200	4400	4900	5100	5300
65 (18)	3800	4000	4200	4400	4700	4900
60 (16)	-	-	-	-	4000	4200

Rating capacity measured in accordance with AHAM DH-1 2008 at 80°F (26.7°C), 60% RH inlet air at 0.0 ESP.

Table 9-4:
Model RL-4 Heat Discharged into Room Space per Hour of Operation (BTU/h)

Temperature dry bulb °F (°C)	% Relative Humidity					
	50	55	60	65	70	75
80 (27)	6000	6400	7000	7500	7700	8300
75 (24)	5500	6000	6400	7000	7300	7700
70 (21)	5100	5500	6000	6400	6800	7000
65 (18)	4900	5100	5500	5700	6200	6400
60 (16)	-	-	-	-	5100	5300

Rating capacity measured in accordance with AHAM DH-1 2008 at 80°F (26.7°C), 60% RH inlet air at 0.0 ESP.

Model RL-6 Dehumidifier Performance Data

Table 10-1:
Model RL-6 Water Removal Capacity in Pounds per Hour (lb/h)

Temperature dry bulb °F (°C)	% Relative Humidity					
	50	55	60	65	70	75
80 (27)	4	5	6	6	7	7
75 (24)	3	4	5	5	6	7
70 (21)	3	3	4	5	5	6
65 (18)	2	3	3	4	5	5
60 (16)	-	-	3	3	4	4

Rating capacity measured in accordance with AHAM DH-1 2008 at 80°F (26.7°C), 60% RH inlet air at 0.0 ESP.

Table 10-2:
Model RL-6 Heat Discharged into Room Space per Hour of Operation (BTU/h)

Temperature dry bulb °F (°C)	% Relative Humidity					
	50	55	60	65	70	75
80 (27)	7400	8000	8900	9500	10200	10600
75 (24)	6700	7400	8000	8700	9300	9800
70 (21)	6300	6700	7400	8000	8700	9100
65 (18)	5600	6100	6700	7200	7800	8200
60 (16)	-	-	6300	6700	7200	7600

Rating capacity measured in accordance with AHAM DH-1 2008 at 80°F (26.7°C), 60% RH inlet air at 0.0 ESP.

Model RL-9 Dehumidifier Performance Data

**Table 11-1:
Model RL-9 Water Removal Capacity in Pounds per Hour (lb/h)**

Temperature dry bulb °F (°C)	% Relative Humidity							
	45	50	55	60	65	70	75	80
85 (29)	6	7	9	10	11	12	13	14
80 (27)	5	7	8	9	10	11	12	13
75 (24)	5	6	7	8	9	10	11	12
70 (21)	4	5	6	7	8	9	10	10
65 (18)	-	4	5	6	7	7	8	9
60 (16)	-	-	-	5	6	6	7	8

Rating capacity measured in accordance with AHAM DH-1 2008 at 80°F (26.7°C), 60% RH inlet air at 0.0 ESP.

**Table 11-2:
Model RL-9 Heat Discharged into Room Space per Hour of Operation (BTU/h)**

Temperature dry bulb °F (°C)	% Relative Humidity							
	45	50	55	60	65	70	75	80
85 (29)	11000	12000	14000	15000	16000	17000	19000	20000
80 (27)	10000	11000	12000	14000	15000	16000	17000	18000
75 (24)	9000	10000	11000	12000	13000	14000	15000	16000
70 (21)	8000	9000	10000	11000	12000	13000	14000	15000
65 (18)	-	8000	9000	10000	11000	11000	12000	13000
60 (16)	-	-	-	9000	9000	10000	11000	12000

Rating capacity measured in accordance with AHAM DH-1 2008 at 80°F (26.7°C), 60% RH inlet air at 0.0 ESP.

Model RL-14, 277V Dehumidifier Performance Data

Table 12-1:
Model RL-14, 277V Water Removal Capacity in Pounds per Hour (lb/h)

Temperature dry bulb °F (°C)	% Relative Humidity							
	45	50	55	60	65	70	75	80
85 (29)	10	12	14	16	18	20	22	23
80 (27)	9	10	13	15	16	18	20	21
75 (24)	7	9	11	12	14	16	17	19
70 (21)	7	8	10	11	13	14	16	17
65 (18)	-	7	8	10	11	12	13	15
60 (16)	-	-	-	8	9	11	12	13

Rating capacity measured in accordance with AHAM DH-1 2008 at 80°F (26.7°C), 60% RH inlet air at 0.0 ESP.

Table 12-2:
Model RL-14, 277V Heat Discharged into Room Space per Hour of Operation (BTU/h)

Temperature dry bulb °F (°C)	% Relative Humidity							
	45	50	55	60	65	70	75	80
85 (29)	19000	22000	24000	26000	28000	30000	32000	34000
80 (27)	17000	19000	21000	24000	25000	27000	29000	31000
75 (24)	15000	17000	19000	21000	23000	25000	26000	28000
70 (21)	14000	15000	17000	19000	21000	23000	24000	25000
65 (18)	-	14000	15000	17000	18000	20000	21000	23000
60 (16)	-	-	-	13000	16000	18000	19000	20000

Rating capacity measured in accordance with AHAM DH-1 2008 at 80°F (26.7°C), 60% RH inlet air at 0.0 ESP.

Model RL-14, 208-240V Dehumidifier Performance Data

Table 13-1:
Model RL-14, 208-240V Water Removal Capacity in Pounds per Hour (lb/h)

Temperature dry bulb °F (°C)	% Relative Humidity				
	40	50	60	70	80
85 (29)	8	12	16	20	24
80 (27)	7	10	14	18	21
75 (24)	6	9	13	16	19
70 (21)	5	8	11	14	17
65 (18)	-	7	10	12	15
60 (16)	-	-	8	10	13

Rating capacity measured in accordance with AHAM DH-1 2008 at 80°F (26.7°C), 60% RH inlet air at 0.0 ESP.

Table 13-2:
Model RL-14, 208-240V Heat Discharged into Room Space per Hour of Operation (BTU/h)

Temperature dry bulb °F (°C)	% Relative Humidity				
	40	50	60	70	80
85 (29)	15000	20000	25000	29000	33000
80 (27)	14000	18000	22000	27000	30000
75 (24)	12000	16000	20000	24000	27000
70 (21)	11000	14000	18000	21000	24000
65 (18)	-	13000	16000	19000	21000
60 (16)	-	-	13000	16000	19000

Rating capacity measured in accordance with AHAM DH-1 2008 at 80°F (26.7°C), 60% RH inlet air at 0.0 ESP.

Model RL-31 Dehumidifier Performance Data

Table 14-1:
Model RL-31 Water Removal Capacity in Pounds per Hour (lb/h)

Temperature dry bulb °F (°C)	% Relative Humidity					
	45	50	55	60	65	70
85 (29)	21	26	30	35	39	43
80 (27)	18	23	26	31	35	39
75 (24)	16	20	23	27	31	34
70 (21)	13	16	20	23	27	30
65 (18)	-	14	17	20	23	26
60 (16)	-	-	-	17	20	23
55 (13)	-	-	-	-	-	20

Rating capacity measured in accordance with AHAM DH-1 2008 at 80°F (26.7°C), 60% RH inlet air at 0.0 ESP.

Table 14-2:
Model RL-31 Heat Discharged into Room Space per Hour of Operation (BTU/h)

Temperature dry bulb °F (°C)	% Relative Humidity					
	45	50	55	60	65	70
85 (29)	36000	42000	47000	52000	56000	61000
80 (27)	33000	38000	42000	47000	51000	55000
75 (24)	29000	34000	38000	42000	46000	50000
70 (21)	26000	29000	33000	37000	41000	45000
65 (18)	-	26000	30000	33000	36000	40000
60 (16)	-	-	-	29000	32000	35000
55 (13)	-	-	-	-	-	31000

Rating capacity measured in accordance with AHAM DH-1 2008 at 80°F (26.7°C), 60% RH inlet air at 0.0 ESP.