

Ultra-sorb® Model XV steam dispersion panel: Mechanical specifications

FIGURE 1-1: ULTRA-SORB MODEL XV DIMENSIONS

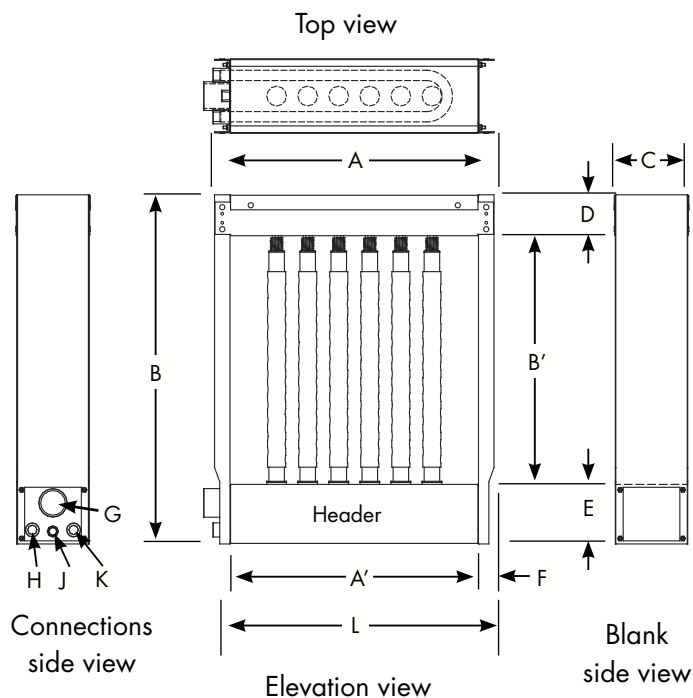

OM-7483

Diameter	lbs/hr	kg/h
1.5"	43	19.5
2.0"	80	36.3

* Consult DriSteam if face height is less than 17" (432 mm) for 1.5" tubes or less than 24" (610 mm) for 2.0" tubes.

Dimension	Inches (mm)
A Unit width	15" (380 mm) min, 147" (3735 mm) max, in 1" (25 mm) increments
A' Face width	12" (305 mm) min, 144" (3660 mm) max, in 1" (25 mm) increments
B Unit height*	21.75" (550 mm) min, 153.75" (3905 mm) max, in 1" (25 mm) increments
B' Face height	12" (305 mm) min, 144" (3660 mm) max, in 1" (25 mm) increments
C Frame depth	7.2" (183 mm)
D Frame enclosure	3.9" (99 mm)
E Header enclosure	5.85" (149 mm)
F Mounting flange	1.5" (38 mm)
G Humidification steam inlet (internal thread)	<ul style="list-style-type: none"> 1" or 2" NPT (DN25 or DN50), determined by maximum steam capacity 3" (DN80) flange, for humidification steam from STS humidifier only
H Pressurized steam inlet (internal thread)	3/4" NPT (DN20)
J Float switch or optional header overflow/ access port (internal thread)	1/2" NPT (DN15)
K Pressurized condensate outlet (internal thread)	3/4" NPT (DN20)
L Overall width	<ul style="list-style-type: none"> 1" (DN25) connection, same as dimension A; 2" (DN50) connection, dimension A + 1" (dimension A + 25 mm) 3" (DN80) flange, dimension A + 6.5" (dimension A + 165 mm)
Control cabinet	See Page 8.
* Panels with unit height more than 120" (3048 mm) have two-piece side flanges and are shipped with brackets for easy field assembly. Panels with unit height more than 98" (2490 mm) are shipped unassembled.	

Installation

FIGURE 2-1: ULTRA-SORB MODEL XV IN A DUCT (HORIZONTAL AIRFLOW ONLY)

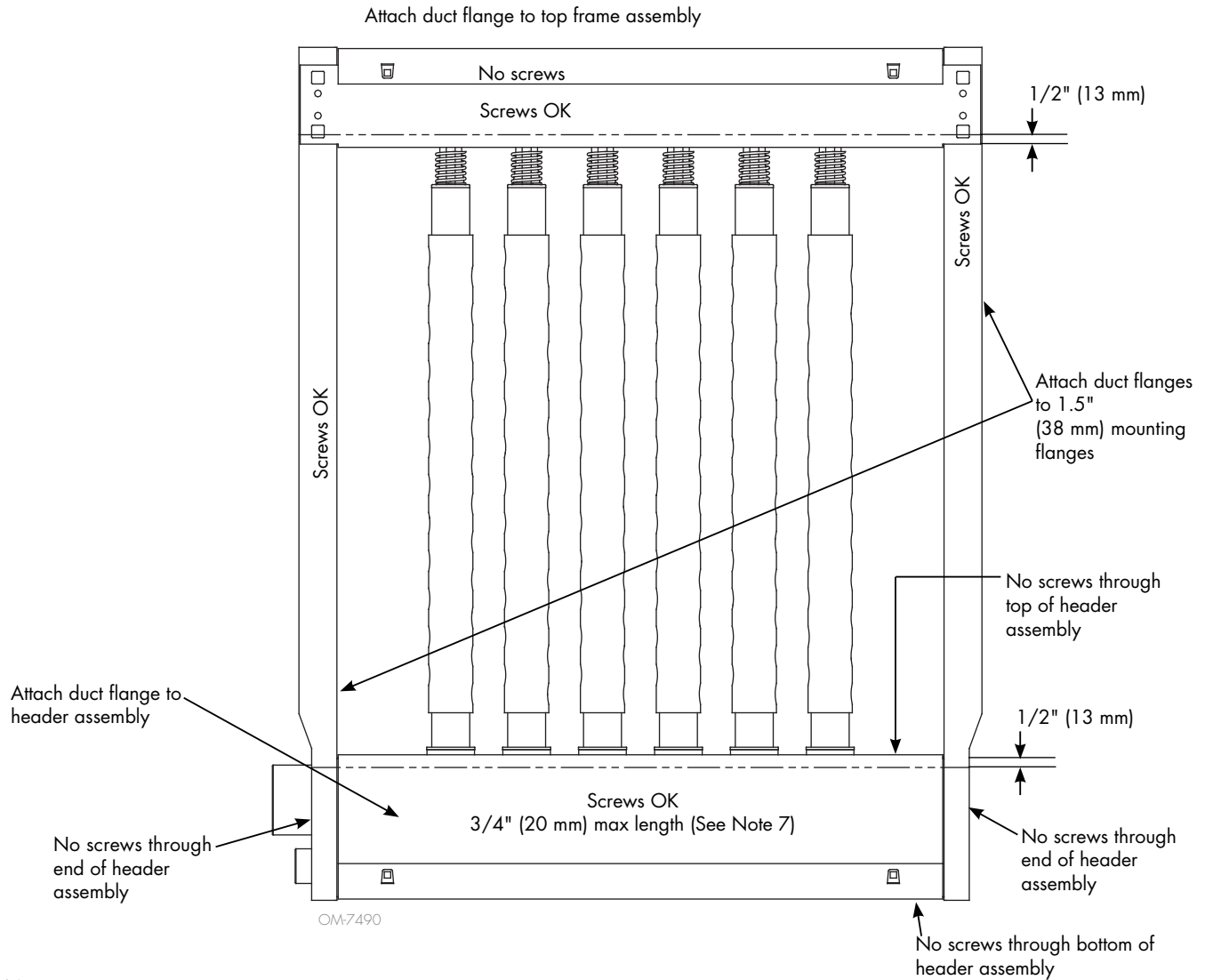

Notes:

1. See Figure 8-2 for trap clearance.
2. Steam supply line to unit and piping are not included.
3. Dispersion tubes are available on 3", 4", 6", 9" and 12" (76, 102, 152, 229, and 305 mm) centers.
4. Ultra-sorb humidifiers will be assembled, crated, and shipped intact in all sizes up to 98" (2490 mm) overall height. Any Ultra-sorb can be shipped unassembled by request, requiring field assembly.
5. Standard sizes are 12" x 12" up to 144" x 144" in 1" increments (305 x 305 mm up to 3660 x 3660 mm in 25 mm increments). Larger sizes are available.
6. Install the panel level. If slope cannot be avoided, ensure that the slope is toward the drain end of the panel.
7. Drill or screw through the header assembly only where shown.
Screws and drill bits must not penetrate more than 3/4" (20 mm) into the header assembly. Use 1/4"-20 nuts and bolts or #12 self drilling and tapping screws for mounting the Ultra-sorb to a metal support frame.

Installation

FIGURE 3-1: ULTRA-SORB MODEL XV IN AN AIR HANDLER (HORIZONTAL AIRFLOW ONLY)

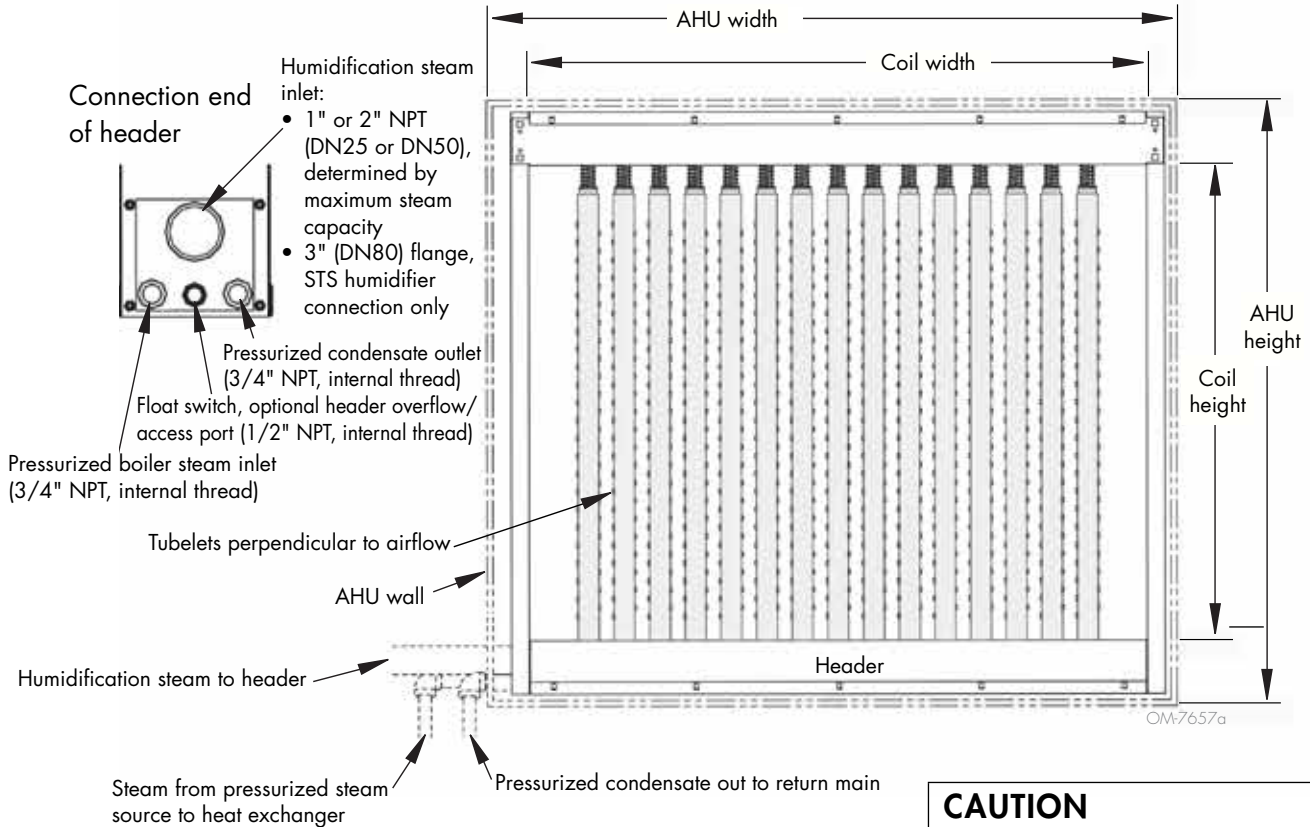

CAUTION
 Use a backup wrench
 Use a backup wrench on all plumbing connections. Failure to use a backup wrench could cause damage to the Ultra-sorb Model XV.

Notes:

1. Dashed lines indicate provided by installer.
2. See Figures 6-2 and 8-2 for trap clearance alternatives.
3. Steam supply line to unit and piping are not included.
4. Dispersion tubes are available on 3", 4", 6", 9" and 12" (76, 102 152, 229, and 305 mm) centers.
5. Ultra-sorb humidifiers will be assembled, crated, and shipped intact in all sizes up to 98" (2490 mm) overall height. Any Ultra-sorb can be shipped unassembled by request, requiring field assembly.
6. Standard sizes are 12" x 12" up to 144" x 144" in 1" increments (305 x 305 mm up to 3660 x 3660 mm in 25 mm increments). Larger sizes are available.
7. Heat exchanger requires 5 psig (35 kPa) minimum steam pressure.

Mounting in an air handling unit

- Metal support frames should be anchored to the air handler casing.
- Drill or screw through the header assembly only where shown in Figure 10-1. Screws and drill bits must not penetrate more than 3/4" (20 mm) into the header assembly.
- Use 1/4-20 nuts and bolts or #12 self drilling and tapping screws.
- Fastener spacing should not to exceed 6" (150 mm).
- When Ultra-sorb Model XV is installed in bypass air applications provide additional bracing is advised for the unsupported side(s).
- Install the panel level. If slope cannot be avoided, ensure that the slope is toward the drain end of the panel.

Installation

Ultra-sorb Model XV heat exchanger must use steam from pressurized steam source only. Humidification steam can be from pressurized steam source or STS steam-to-steam humidifier.

Ultra-sorb Model XV must be installed in horizontal airflows only.

To avoid puncturing the header, screws and drill bits must not penetrate more than 3/4" (20 mm) into the header assembly. See Figure 2-1 for allowable drill and screw locations.

MOUNTING IN A DUCT

Mounting flanges on both sides of the unit and the header and frame can be used as mounting surfaces (see Figure 2-1). A matching flange or metal frame is required on the ductwork for connection to the Ultra-sorb flanges. The recommended fastener is a #12 self-drilling and tapping screw 3/4" (20 mm) long, spacing not to exceed 12" (305 mm). If an angle-iron frame is provided on the duct section, a longer screw may be required.

MOUNTING IN AN AIR HANDLER

Metal support frames should be anchored to the air handler casing. Recommended fasteners for mounting the Ultra-sorb to a metal support frame are 1/4" - 20 nuts and bolts or #12 self drilling and tapping screws. Due to possible forces exerted on this application, fastener spacing should not exceed of 6" (150 mm).

FIGURE 4-1: PREVENTING DUCT STATIC PRESSURE LOSS

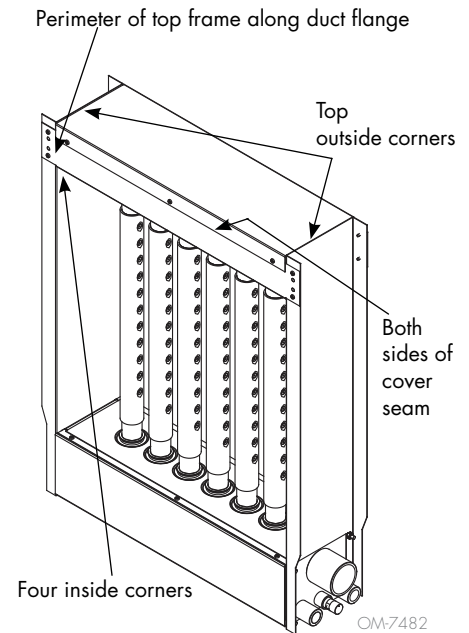

Ultra-sorb panels that penetrate a duct section must be sealed with HVAC caulking or a similar weather sealant to prevent air leakage.

Table 4-1:
Ultra-sorb XV air pressure loss

Duct air velocity (55 °F [13 °C] at sea level)		Tube spacing					
		3" (75 mm) - 1.5" (38 mm) tube		4" (102 mm) - 2" (50 mm) tubes		6" (150 mm) - 1.5" (38 mm) tube	
fpm	m/s	wc	Pa	wc	Pa	wc	Pa
500	2.54	0.033	8.3	0.033	8.3	0.005	1.3
1000	5.08	0.121	30.2	0.121	30.2	0.020	5.1
1500	7.62	0.237	59.2	0.237	59.2	0.046	11.5

Notes:

- Ultra-sorb panels with 9" (225 mm) or 12" (300 mm) tube spacings have no measurable air pressure loss.
- Use DriSteem's DriCalc sizing and selection software to calculate your specific air pressure loss.

Installation

HEAT EXCHANGER PRESSURIZED BOILER STEAM INLET

Steam pressure for steam entering the heat exchanger must be least 5 psig (35 kPa) to vaporize condensate in the header.

HUMIDIFICATION STEAM INLET

Humidification steam entering the header can be from a modulating steam valve or from an STS humidifier. See interconnecting piping requirements for STS humidifier applications in Table 6-1.

FIGURE 5-1: LIFTING CONDENSATE WITH ULTRA-SORB MODEL XV

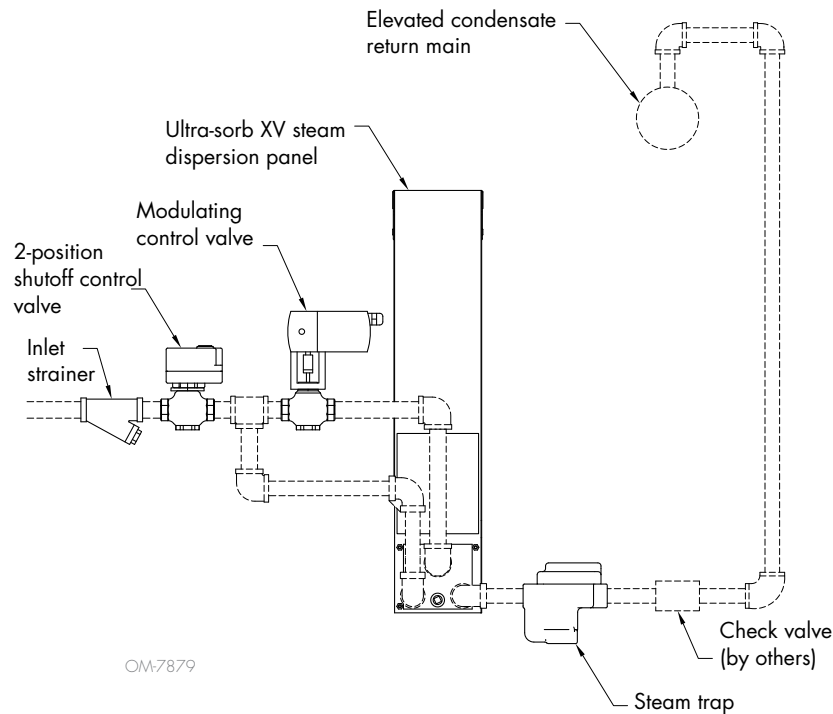

Installation

FIGURE 6-1: ULTRA-SORB MODEL XV PIPING COMPONENTS WITH ON/OFF SHUTOFF VALVE, FLOAT SWITCH, PRESSURIZED STEAM SOURCE

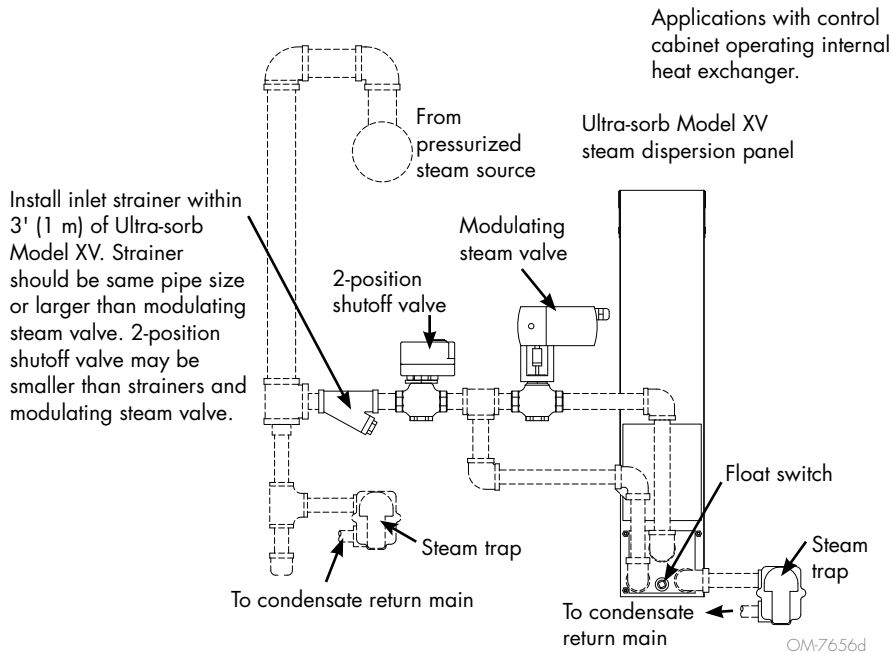

OPTIONAL HEADER OVERFLOW P-TRAP WATER SEAL

Ultra-sorb Model XV is designed to vaporize the condensate generated in a properly designed, installed, operated, and maintained system. An optional, header overflow P-trap may be installed as an option to the float switch.

FIGURE 6-2: ULTRA-SORB MODEL XV OPTIONAL HEADER OVERFLOW P-TRAP WATER SEAL

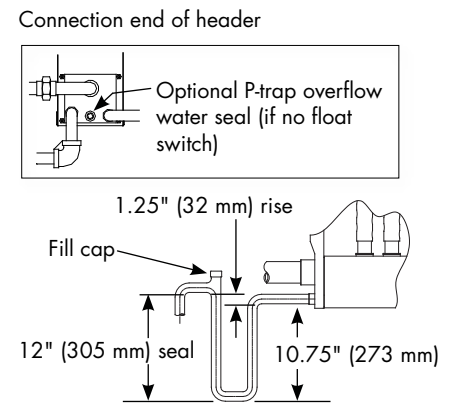

Table 6-1:

Maximum steam carrying capacity and length of interconnecting steam tubing¹

Copper or stainless steel tubing, nonpressurized steam from STS humidifier					
Tube size		Maximum capacity ²		Maximum developed length ³	
inches	DN	lbs/hr	kg/h	ft	m
2	50	220	100	30	9
3 ⁴	80 ⁴	450	204	80	24

1. Based on total maximum pressure drop in tubing of 5" wc (1250 Pa).
2. Insulate tubing to minimize loss of capacity and efficiency.
3. Developed length of tubing equals measured length plus 50% of measured length, to account for fittings. Longer tubing lengths are possible at capacities lower than listed maximums. Consult factory.
4. Requires flange connection.

Installation

FIGURE 7-1: ULTRA-SORB MODEL XV PIPING WITH STS HUMIDIFIER

Steam to heat exchanger from pressurized steam source, humidification steam from STS humidifier

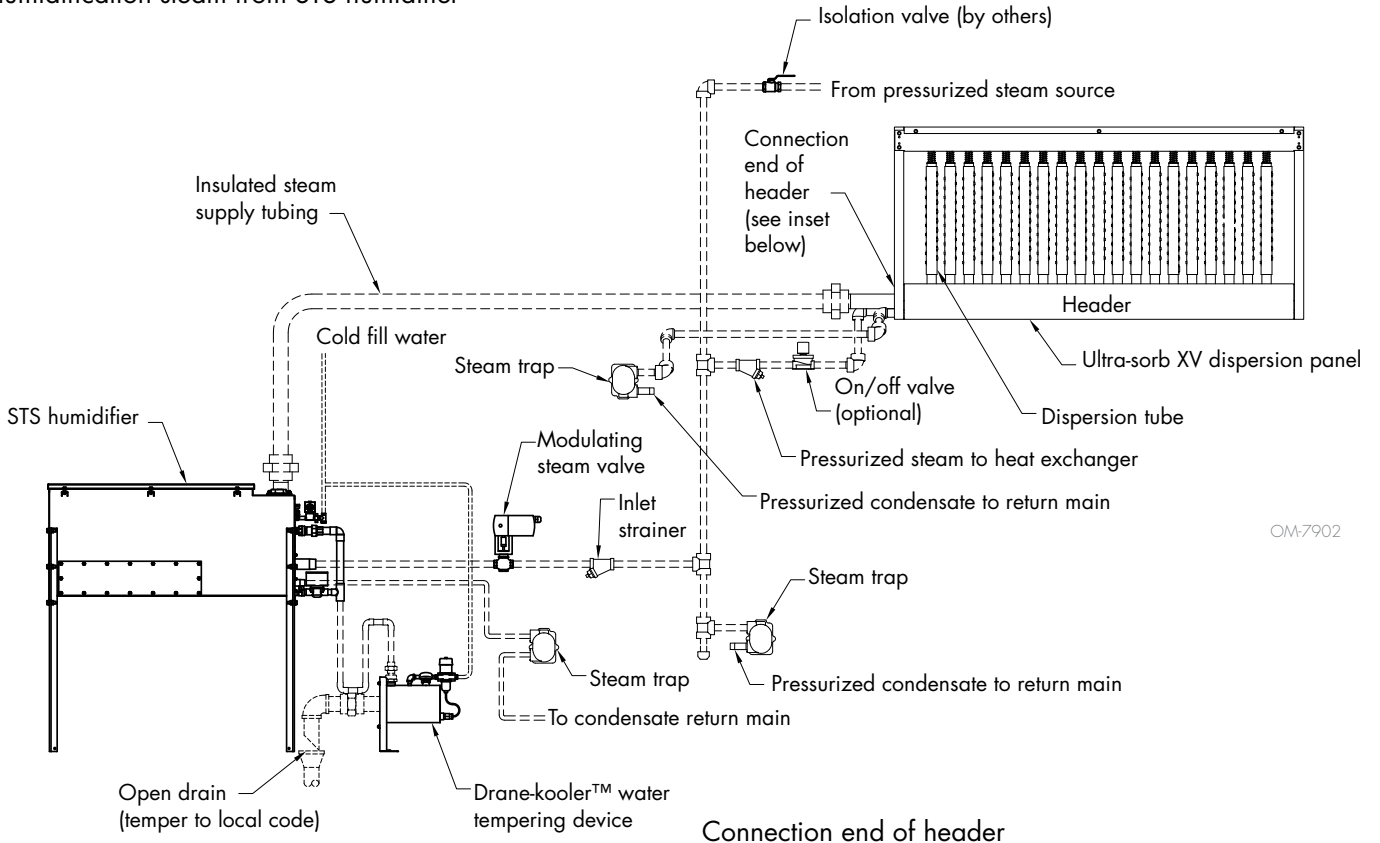

OM-7902

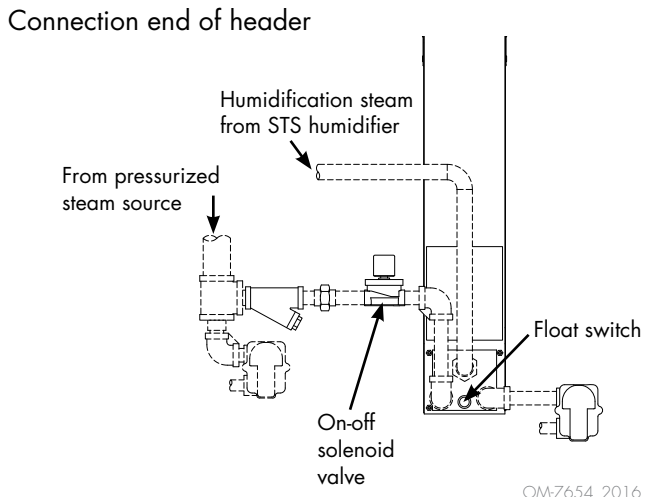

OM-7654_2016

Note: Tubing union shown at steam connection. For STS humidifier, connection may also be 3" (DN80) flange.

Installation

FIGURE 8-1: CONTROL OPTION #1 - DRISTEEM CONTROL CABINET (SEE PAGE 9)

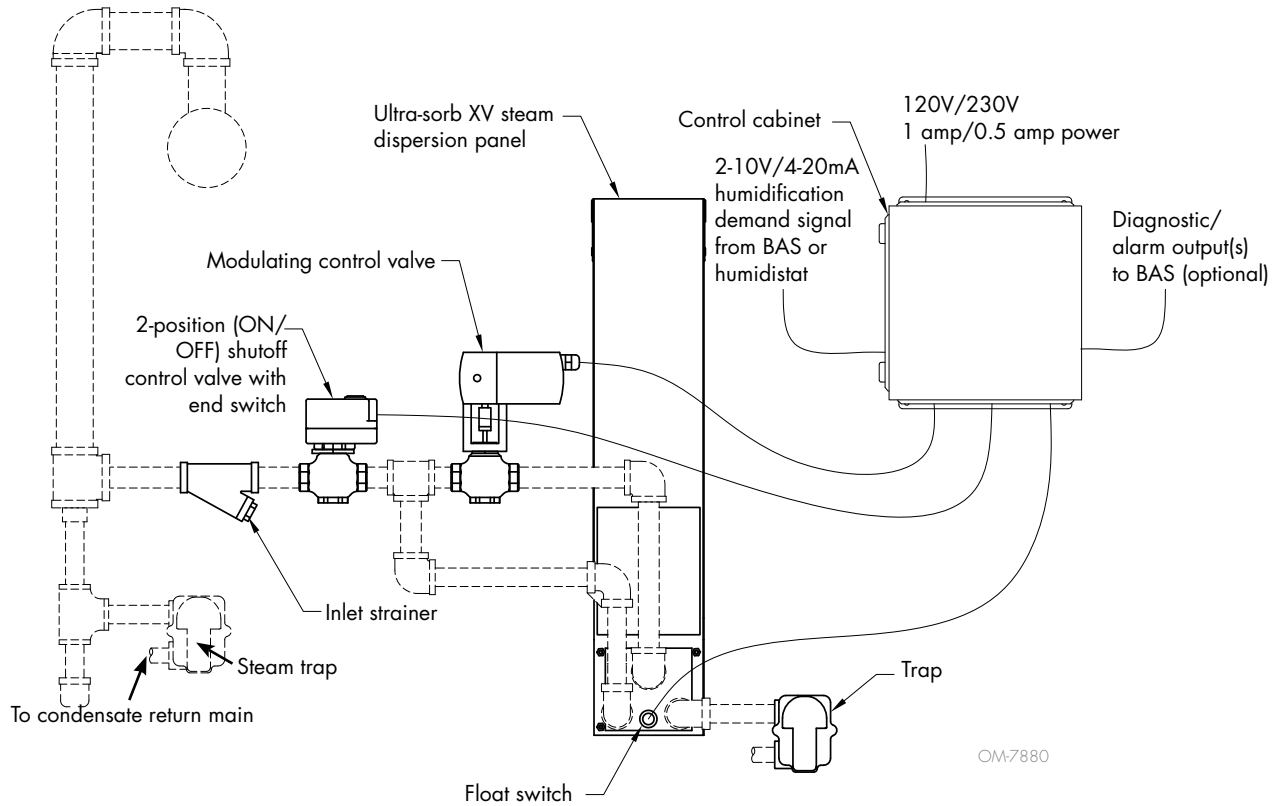
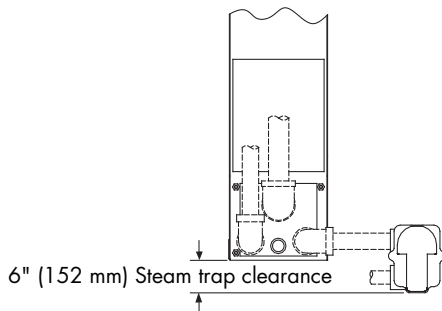

FIGURE 8-2: ULTRA-SORB MODEL XV STEAM TRAP DIMENSIONS



Note: Dashed lines indicate provided by installer.

OM-7655

FIGURE 8-3: ULTRA-SORB MODEL XV CONTROL CABINET

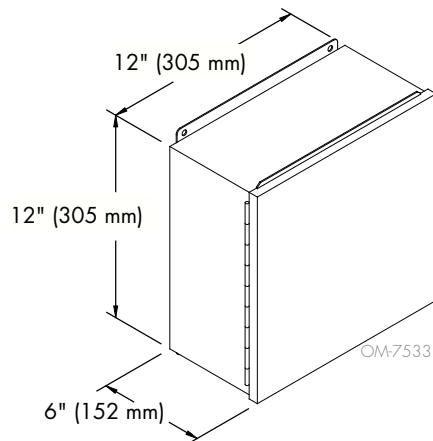

Notes:

- Electrical power requirements: 120 VAC, 1.0 Amps, or 230 VAC, 0.5 Amps
- Components are 24 VAC, powered by a transformer in the control cabinet. 50 VA available from internal transformer for operation of two 24 VAC control valves.
- Maximum distance from control cabinet to Ultra-sorb Model XV is 50' (15 m).

Controls

CONTROL OPTIONS

CONFIRMING STEAM DISPERSION PANEL CONFIGURATION

The Ultra-sorb XV steam dispersion panel utilizes a built-in heat exchanger to evaporate condensate generated in the humidification process. For maximum energy efficiency, a unique control sequence operates a 2-position shutoff valve for the heat exchanger, in addition to a modulating valve for humidification control. A float switch in the steam dispersion panel header, along with control sequence timings assure effective condensate management along with humidification output based on demand.

CONTROL OPTION #1 - DRISTEEM CONTROL CABINET

The Ultra-sorb XV dispersion panel is provided with controls by DriSteem. Operation of both the 2-position shutoff valve, and modulating control valve is coordinated by the electronic controller provided in the DriSteem control cabinet. A 4-20 mA or 2-10 VDC humidity demand signal is sent to the DriSteem controller, and the controller opens/closes the two steam valves based on the demand signal and inputs including the steam dispersion panel float switch, and (optionally) a duct air flow switch and humidity high limit control.

DEMAND SIGNAL FROM BAS

The demand signal to the controller is sent from a control system (BAS). Less than 2 VDC/4 mA represents no humidity demand, and 10 VDC/20 mA represents 100% demand.

DEMAND SIGNAL FROM MODULATING HUMIDISTAT

Alternately, the demand signal may be provided to the controller from a modulating humidistat with a 2-10 VDC/4-20 mA output. Set the humidistat proportional band (PB) at 10-20% for stable control range.

Connect the demand signal wiring to terminal block P11.

Configure the demand signal type for voltage (2-10 VDC) or current (4-20 mA) by choosing to include or remove the jumper at terminal block P15. A wiring diagram is included with the unit.

FLOAT SWITCH

Wire the float switch to the DriSteem control cabinet. A wiring diagram is included with the unit.

Under normal conditions the float switch in the Ultra-sorb Model XV header is closed, and the modulating steam valve or STS humidifier operates according to the humidification control system's call for humidity. In the event condensate levels rise in the humidifier header, the float switch rises and the circuit opens, activating a condensate mitigation sequence.

FIGURE 9-1: ORIENTATION MARK ON FLOAT SWITCH

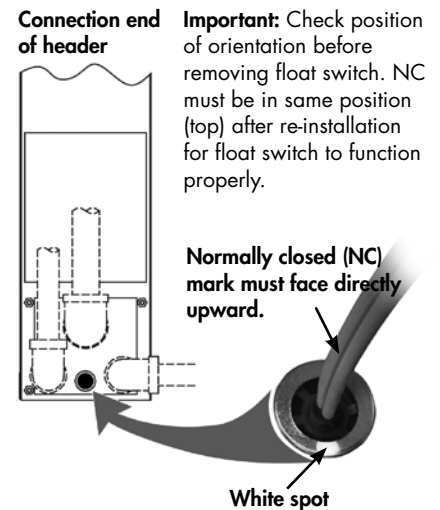

Important:

Failure to follow these wiring procedures can result in erratic operation or failure.

This product has been tested at the factory for proper operation. Product failures resulting from faulty handling, incorrect wiring, or shorting of wires together on external components are not covered under your DriSteem warranty. Review information and diagrams before proceeding.

Controls

TEMPERATURE SWITCH (OPTIONAL)

Install the temperature switch to prevent the header from flooding with condensate if the heat exchanger cools, such as if the condensate return main becomes flooded or the trap fails closed. DriSteem's temperature switch is a temperature-actuated make-break switch. The temperature at which it switches is adjustable and should be set at 210 °F (99 °C).

AIR FLOW SWITCH

Air flow indication is required. Indication can be provided by a BAS input or air flow switch wired to the DriSteem control cabinet. Wire the air flow switch to the DriSteem control cabinet as shown in the diagram included with the unit. If a duct high limit humidistat is also used, wire the air flow switch in series with the high limit humidistat. The steam dispersion panel will not run if the air flow switch/duct high limit input of the DriSteem controller is left open. A circuit-closing jumper is provided on the controller board input and must be removed to the air flow/high limit input.

HIGH LIMIT HUMIDISTAT

Wire the duct high limit humidistat to the DriSteem control cabinet.

Controls

CONTROL OPTION #2 – ELECTRIC TEMPERATURE SWITCH ONLY; CONTINUOUS HEAT EXCHANGER OPERATION

The DriSteem control cabinet is not provided. An electric modulating control valve is controlled by a 2-10 VDC/4-20 mA signal from a control system (BAS) or modulating humidistat. Optional air flow switch, high limit humidistat are wired in series with 24 VAC control circuit of the modulating control valve. See the wiring diagrams provided with the unit.

ELECTRIC TEMPERATURE SWITCH

Install the temperature switch to prevent the header from flooding with condensate if the heat exchanger cools, such as if the condensate return main becomes flooded or the trap fails closed. DriSteem's temperature switch is a temperature-actuated make-break switch. The temperature at which it switches is adjustable and should be set at 210 °F (99 °C).

- Install the sensing element of the temperature switch in the condensate return piping between the Ultra-sorb heat exchanger outlet and the inlet to the steam trap. Include a tee with a 1/2" (DN15) pipe thread opening to receive the sensing element. When steam surrounds the sensing element, the switch will "make," allowing the steam dispersion panel valve to open.
- Install all wiring according to national and local electrical codes, and size transformer VA to load VA.
- When using a temperature switch to control the on-off heat exchanger valve, follow the wiring instructions supplied with the modulating humidification-steam control valve.

CONTROL OPTION #3 – PNEUMATIC TEMPERATURE SWITCH ONLY; CONTINUOUS HEAT EXCHANGER OPERATION

The DriSteem control cabinet is not provided. A pneumatic modulating control valve is sent a 3-15 PSI signal from a pneumatic humidistat or other pneumatic device, to modulate the valve based on humidity demand.

- The 2-position shutoff valve is not used. Steam supply to the panel's internal heat exchanger is continuous.

PNEUMATIC TEMPERATURE SWITCH

The temperature switch will prevent the header from flooding with condensate by closing the modulating steam valve if the heat exchanger cools (if the condensate return main becomes flooded or the trap fails closed). DriSteem's pneumatic temperature switch is a temperature-actuated open-closed pneumatic switch. The pneumatic signal (3-15 PSI) is maintained above 210°F (99°C) and is opened (bled off) below 200°F (93°C).

Controls

CONTROL OPTION #4 – CONTROLS BY BAS/CONTROLS CONTRACTOR

The BAS or controls contractor will provide the necessary controller and programming logic to sequence the steam dispersion panel valves as described for Control Option #1. This includes providing control outputs for the modulating control valve and 2-position shutoff valve. Refer to the BAS controls contractor wiring diagrams for specific valve and float switch connection terminals.