

CRUV™ DI EVAPORATIVE HUMIDIFIER
WIRING DIAGRAM W/RELAY-DELAY

DATE	REV	RECORD	DR
3/14	D	E.C.# 6238	JK
4/17	E	E.C.# 6551	JK
4/21	F	E.C.# 6969	JK

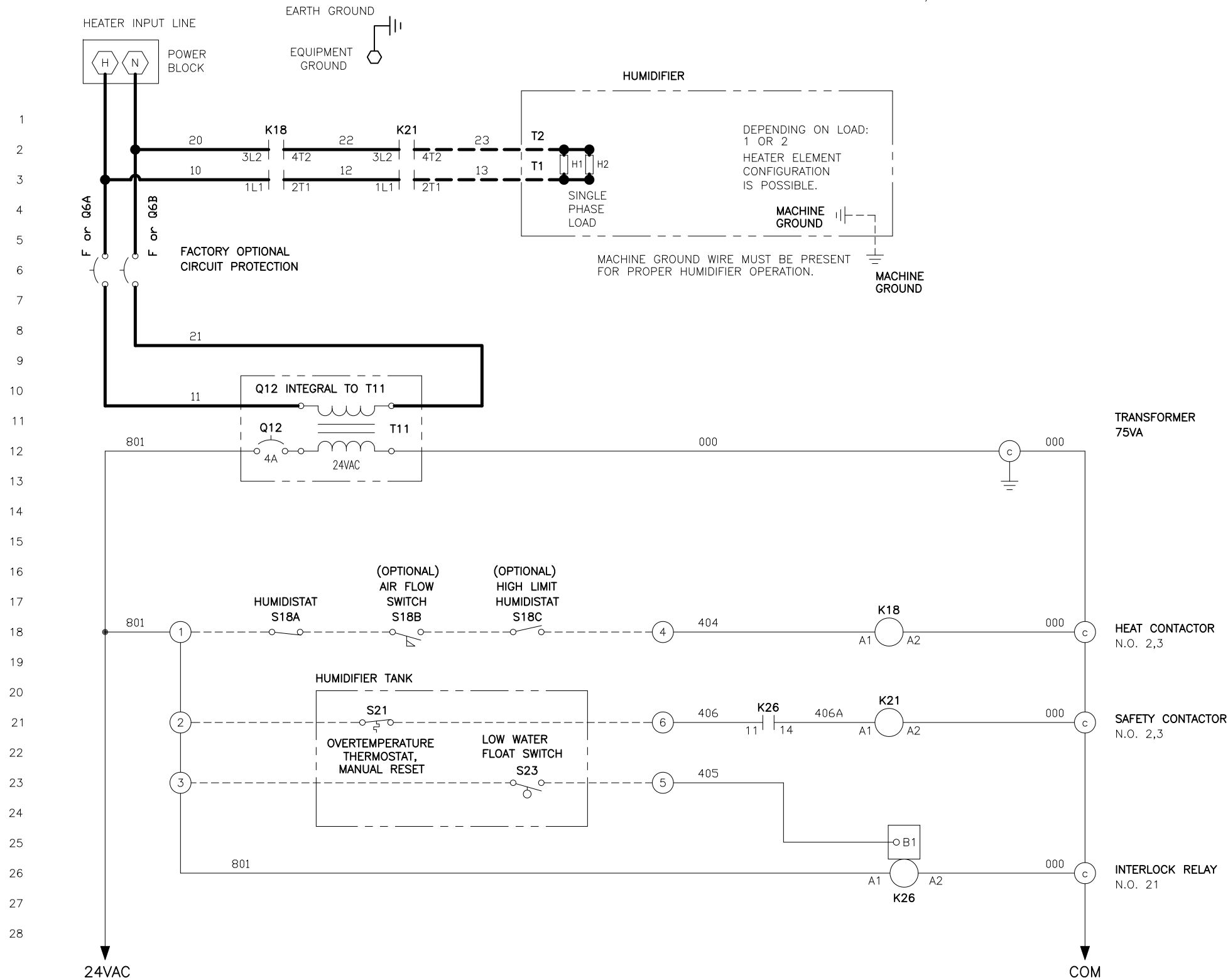

NOTES:

- FOR THREE PHASE SYSTEM, THE THREE PHASE LOAD IS USED AND THIS WIRE IS FACTORY INSTALLED.
- REFER TO CRUV ELECTRICAL DATA SHEET.

BREAK TO EXTERNAL CONNECTIONS DIAGRAM

LEGEND

POWER WIRING	K	RELAY/CONTACTOR	Y	SOLENOID
CONTROL CIRCUIT WIRING	T	TRANSFORMER	N	SENSOR
FIELD WIRING	Q	CIRCUIT BREAKER	J	JUMPER
	S	SWITCH	E	WATER PROBE
	H	HEATER	M	MOTOR/FAN

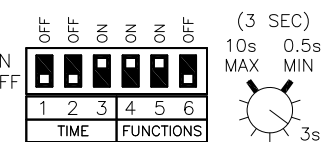

	CRUV, DI WATER, ON/OFF CTRL 120 V. DIAGRAM	
	SCALE:	P/N
DRAWN BY: KROG	CR-RELAY-2	
DATE: 5/11/05		