

CRUV™ DI EVAPORATIVE HUMIDIFIER
WIRING DIAGRAM W/RELAY-DELAY SHIPPED LOOSE

| DATE | REV | RECORD | DR |
|------|-----|------------|----|
| 5/12 | B | E.C.# 5803 | JK |
| 3/13 | C | E.C.# 6053 | JK |
| 3/14 | D | E.C.# 6238 | JK |

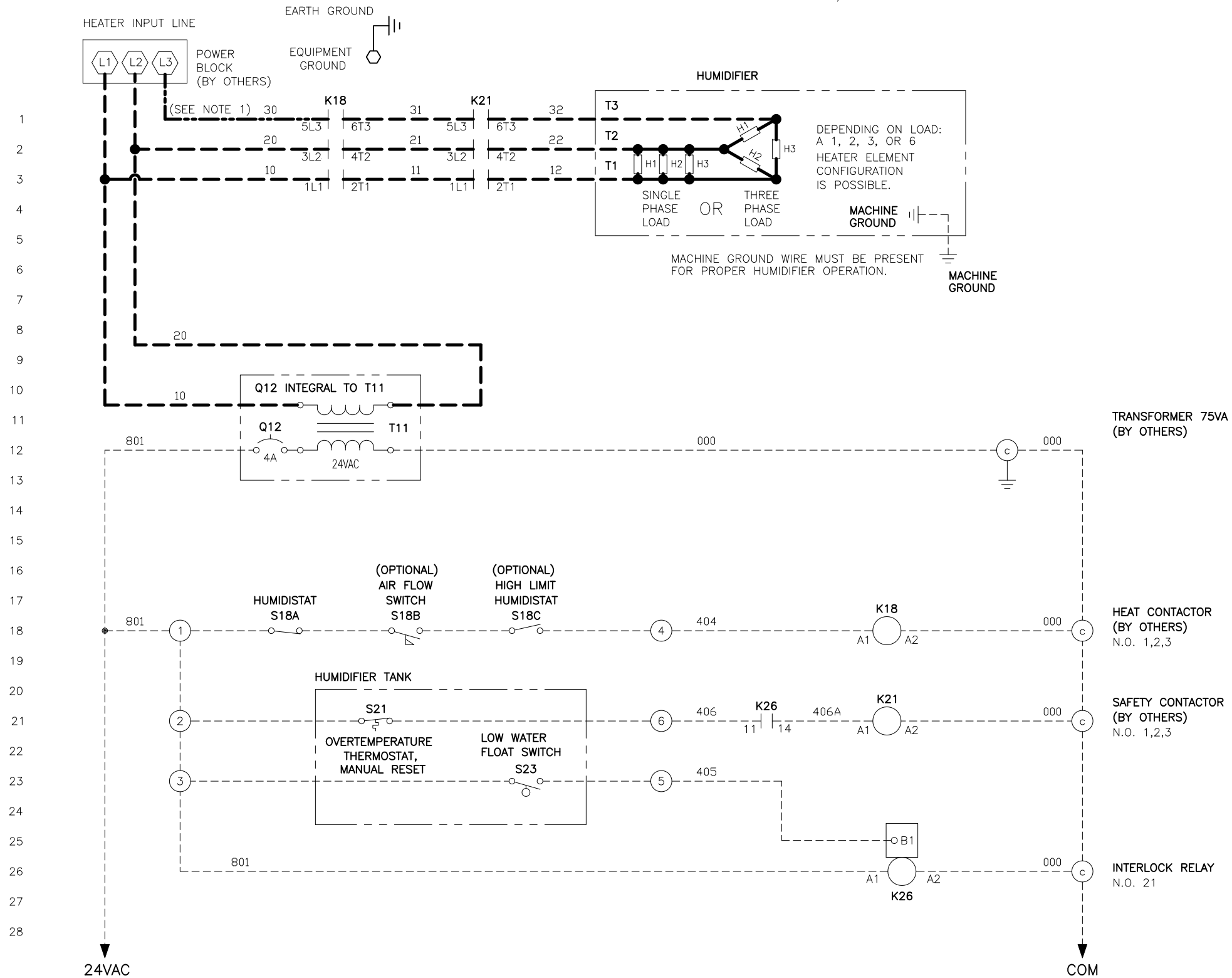

NOTES:

- FOR THREE PHASE SYSTEM, THE THREE PHASE LOAD IS USED AND THIS WIRE IS FACTORY INSTALLED.
- REFER TO CRUV ELECTRICAL DATA SHEET.

BREAK TO EXTERNAL CONNECTIONS DIAGRAM

| LEGEND | | |
|------------------------|---|-----------------|
| POWER WIRING | K | RELAY/CONTACTOR |
| CONTROL CIRCUIT WIRING | T | TRANSFORMER |
| FIELD WIRING | Q | CIRCUIT BREAKER |
| | S | SWITCH |
| | H | HEATER |
| | Y | SOLENOID |
| | N | SENSOR |
| | J | JUMPER |
| | E | WATER PROBE |
| | M | MOTOR/FAN |

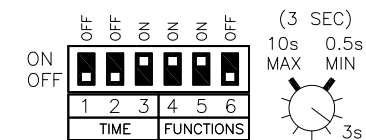

| | | |
|--|---|-------------------|
| | CRUV, DI WATER, ON/OFF CONTROLS DELAY & RELAY SHIPPED LOOSE | |
| | SCALE: DRAWN BY: KROG DATE: 12/22/08 | P/N CR-RELAY-3 |