

RTS EVAPORATIVE HUMIDIFIER

**OBSOLETE**

DATE	REV	RECORD	DR
7/21	D	E.C.# 7004	JK
7/23	D	E.C.# 7181	AJK

REFER TO FOLLOWING DOCUMENTS  
 -INSTALLATION REQUIREMENTS  
 -EXTERNAL CONNECTIONS  
 -HEATER ELEMENT WIRING ARRANGEMENTS

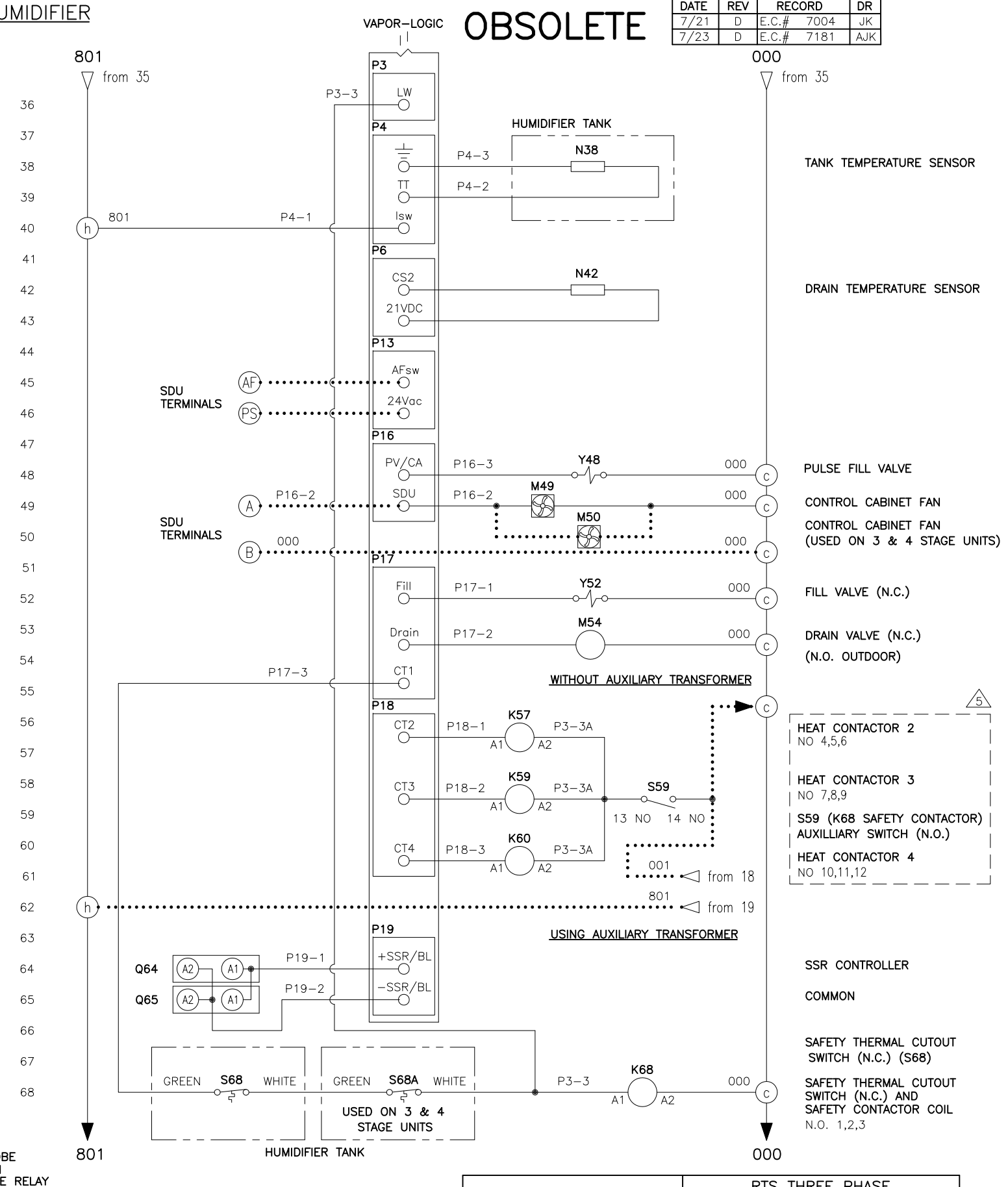
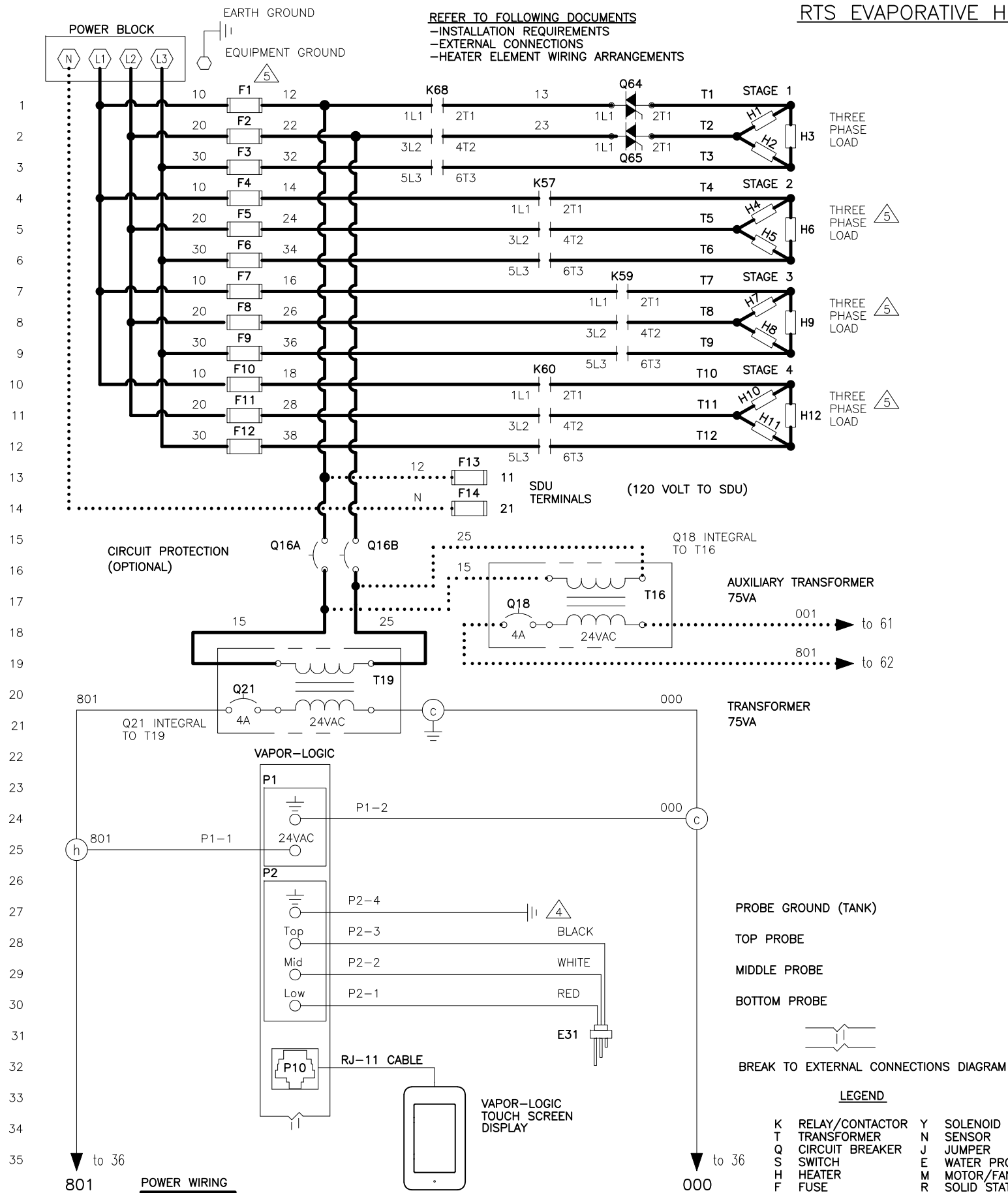

POWER WIRING  
 CONTROL CIRCUIT WIRING  
 FIELD WIRING  
 OPTIONAL FACTORY  
 OPTIONAL FIELD

NOTES:  
 1. WIRING AND BRANCH CIRCUIT PROTECTION PROVIDED BY INSTALLER AS PER NATIONAL ELECTRICAL CODE.  
 2. FOR SUPPLY HEATER AND MACHINE GROUND CONNECTIONS, SIZE WIRE USING 75°C WIRE TABLE PER NATIONAL ELECTRICAL CODE.

3. USE COPPER CONNECTORS RATED FOR 105°C.  
 4. WATER LEVEL PROBE GROUND MUST BE CONNECTED TO TANK FOR PROPER HUMIDIFIER OPERATION.

5. WIRING DIAGRAM SHOWS MAXIMUM NUMBER OF STAGES. YOUR PARTICULAR HUMIDIFIER MAY HAVE LESS. ON SINGLE STAGE UNITS, FUSES AND FUSE BLOCKS ARE OMITTED.

		RTS THREE PHASE WIRING DIAGRAM 208V	
		MAT'L:	P/N
SCALE:	DATE: 10/21/20	RTS-VL-4	