

STS® DI EVAPORATIVE HUMIDIFIER WIRING DIAGRAM W/VL®

DATE	REV	RECORD	DR
5/15	A	E.C.# 6396	JK
5/18	B	E.C.# 6686	JK

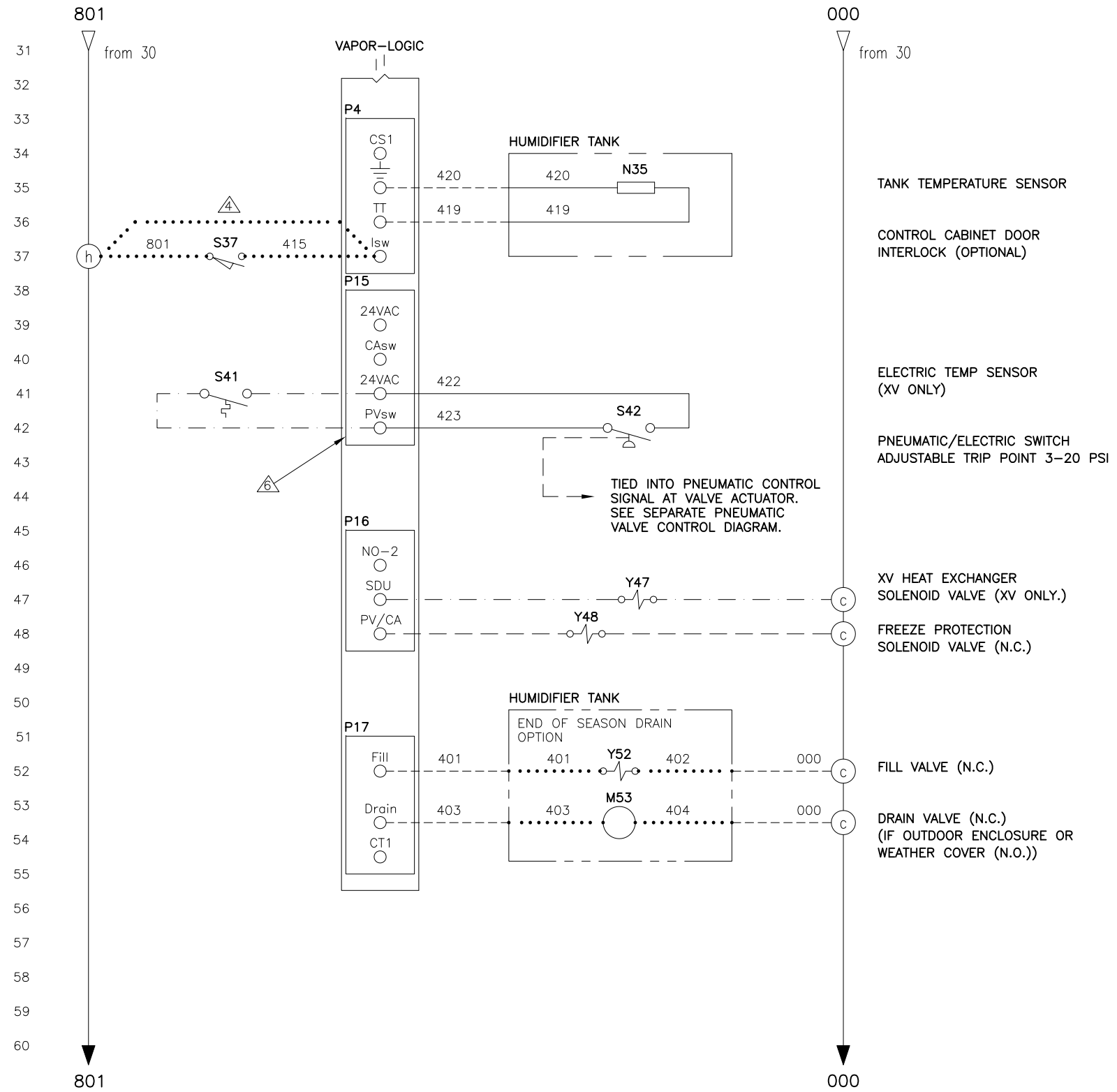
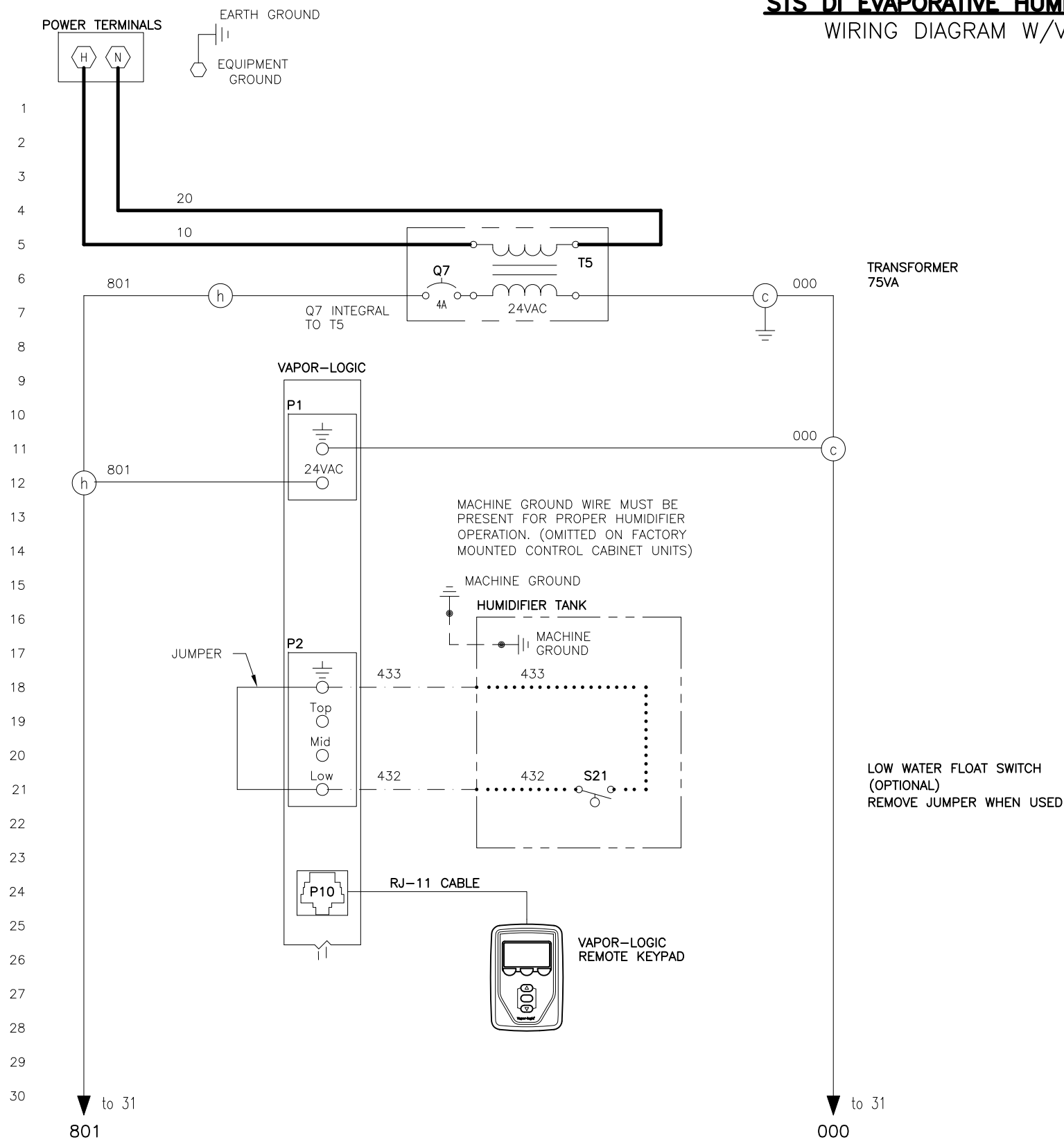

POWER WIRING
CONTROL CIRCUIT WIRING
FIELD WIRING
OPTIONAL FACTORY
OPTIONAL FIELD

- NOTES:**
1. WIRING AND BRANCH CIRCUIT PROTECTION PROVIDED BY INSTALLER AS PER NATIONAL ELECTRICAL CODE.
 2. FOR SUPPLY AND MACHINE GROUND CONNECTIONS, SIZE WIRE USING 75°C WIRE TABLE PER NATIONAL ELECTRICAL CODE.
 3. USE COPPER CONNECTORS RATED FOR 105°C.

4. IF THE INTERLOCK SWITCH IS NOT USED, THEN WIRE DIRECTLY TO TERMINAL SWITCH.
5. REFER TO STS ELECTRICAL DATA SHEET.
6. REMOVE SHUNT J404 FROM BOARD IF USING OPTIONAL ACCESSORY.

BREAK TO EXTERNAL CONNECTIONS DIAGRAM

LEGEND

K	RELAY/CONTACTOR	Y	SOLENOID
T	TRANSFORMER	N	SENSOR
Q	CIRCUIT BREAKER	J	JUMPER
S	SWITCH	E	WATER PROBE
H	HEATER	M	MOTOR/FAN

		STS, DI WATER PNEUMATIC ACTUATOR WIRING DIAGRAM	
		SCALE:	P/N
DRAWN BY: JK		STS-VL-2	
DATE: 5/21/15			