

VAPORSTREAM® VLC EVAPORATIVE HUMIDIFIER

100% (DUAL) SSR MOD WITH SDU/AREA & TRANSFORMER

REFER TO FOLLOWING DOCUMENTS
 -INSTALLATION REQUIREMENTS
 -EXTERNAL CONNECTIONS
 -HEATER ELEMENT WIRING ARRANGEMENTS

DATE	REV	RECORD	DR
5/05	D	E.C. # 4263	JK
2/07	E	E.C. # 4504	JK

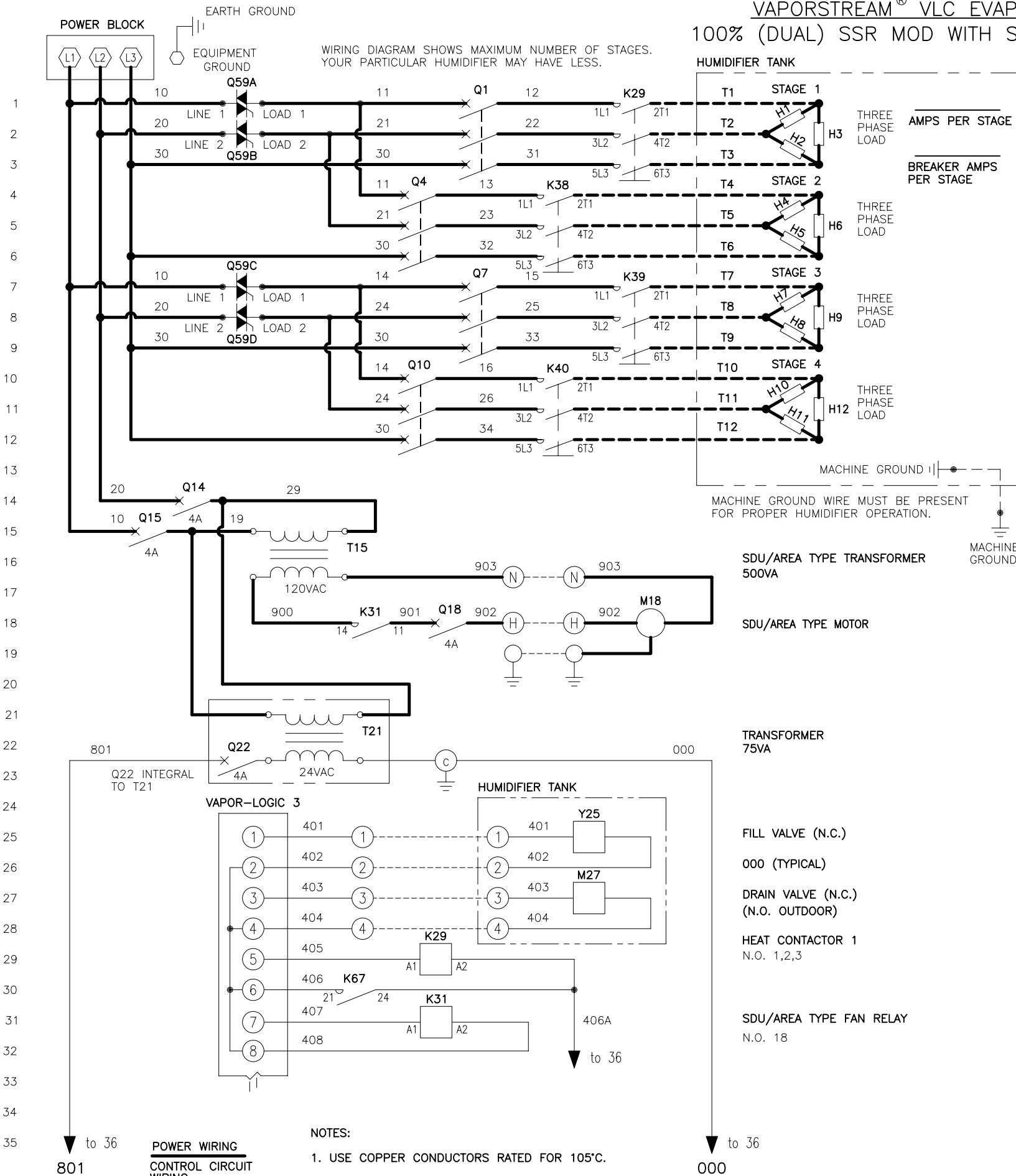

- NOTES:
- USE COPPER CONDUCTORS RATED FOR 105°C.
 - WIRING AND BRANCH CIRCUIT PROTECTION PROVIDED BY INSTALLER.

LEGEND

K	RELAY/CONTACTOR	Y	SOLENOID
T	TRANSFORMER	N	SENSOR
Q	CIRCUIT BREAKER	J	JUMPER
S	SWITCH	E	WATER PROBE
H	HEATER	M	MOTOR/FAN

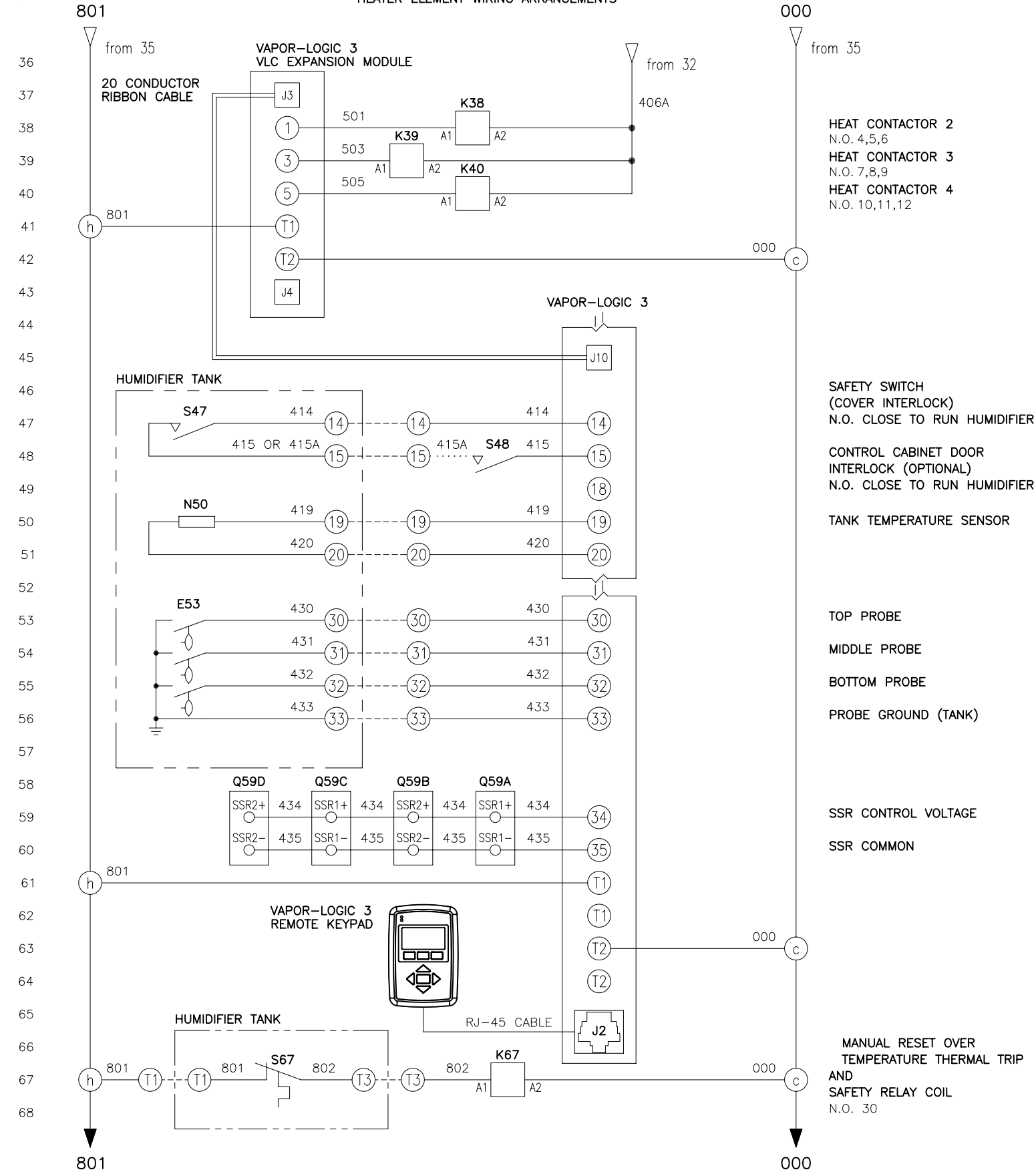

PROGRAM CODE: _____

MODEL: _____

ORDER NO: _____

PRIMARY VOLTAGE: _____ PH: 3 HZ: 50

TOTAL UNIT AMPS: _____

EUROPEAN VLC, STD WATER, (2) SSR'S, SDU W/TRANS DIAGRAM

MATL: _____

SCALE: _____ P/N

DRAWN BY: KR0G

DATE: 10/23/00

DRISTEEM®

VLC-CE-VL3-2

POWER WIRING
 CONTROL CIRCUIT WIRING
 FIELD WIRING
 OPTIONAL FACTORY
 OPTIONAL FIELD

BREAK TO EXTERNAL CONNECTIONS DIAGRAM