

XTPE TWO ELECTRODE STEAM HUMIDIFIER

REFER TO FOLLOWING DOCUMENTS
 -INSTALLATION REQUIREMENTS
 -EXTERNAL CONNECTIONS

DATE	REV	RECORD	DR
1/22	F	E.C.# 7049	JK
4/23	G	E.C.# 7128	JK
7/23	H	E.C.# 7195	SBK

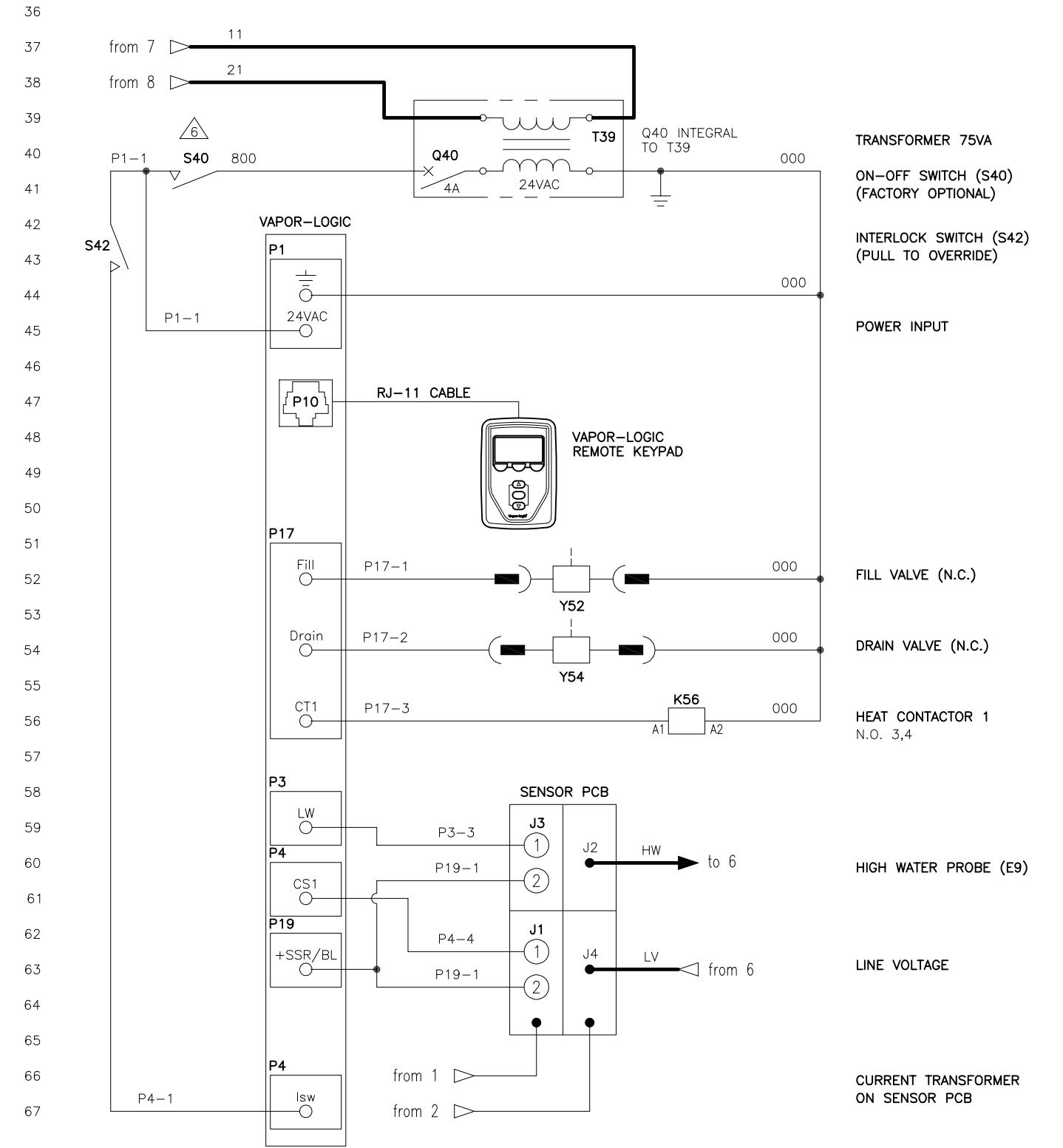
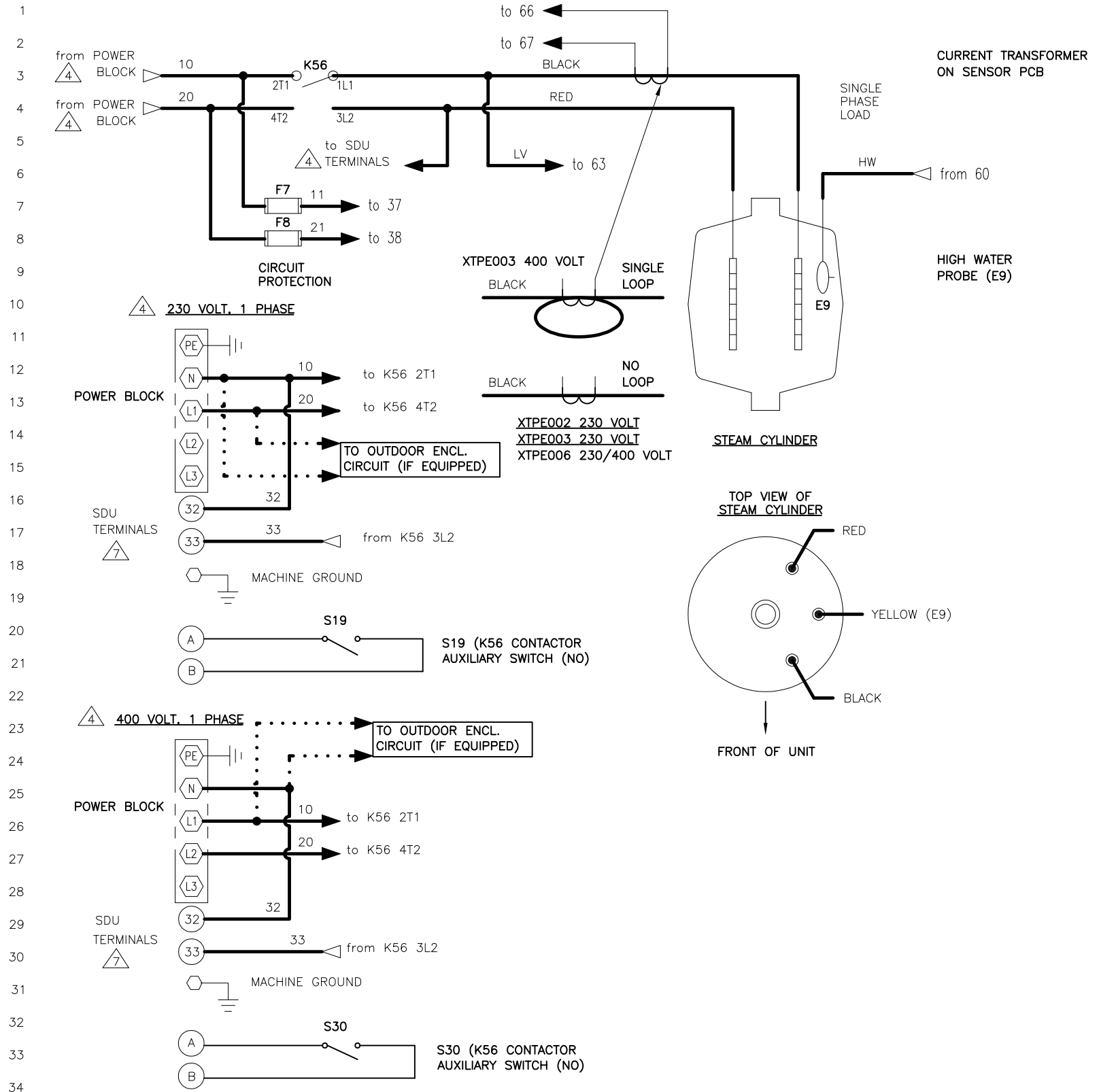

BREAK TO EXTERNAL CONNECTIONS DIAGRAM

- NOTES**
1. WIRING AND BRANCH CIRCUIT PROTECTION PROVIDED BY INSTALLER AS PER NATIONAL ELECTRICAL CODE.
 2. FOR SUPPLY HEATER AND MACHINE GROUND CONNECTIONS, SIZE WIRE USING 75°C WIRE TABLE PER NATIONAL ELECTRICAL CODE.
 3. USE COPPER CONNECTORS RATED FOR 105°C.

- △ SEE VOLTAGE SPECIFIC WIRING DETAIL
- △ INDOOR ENCLOSURE ONLY
- △ WIRES 32 AND 33 NOT INSTALLED ON OUTDOOR ENCLOSURE MODELS

XTPE TWO ELECTRODE	
	MAT'L: SCALE: DRAWN BY: ECR DATE: 5/18
P/N XTPE-VL-1	