

# XTS THREE ELECTRODE STEAM HUMIDIFIER

REFER TO FOLLOWING DOCUMENTS  
 -INSTALLATION REQUIREMENTS  
 -EXTERNAL CONNECTIONS

DATE	REV	RECORD	DR
1/14	I	E.C.# 6172	JK
5/17	J	E.C.# 6551	JK
6/17	K	E.C.# 6586	JK

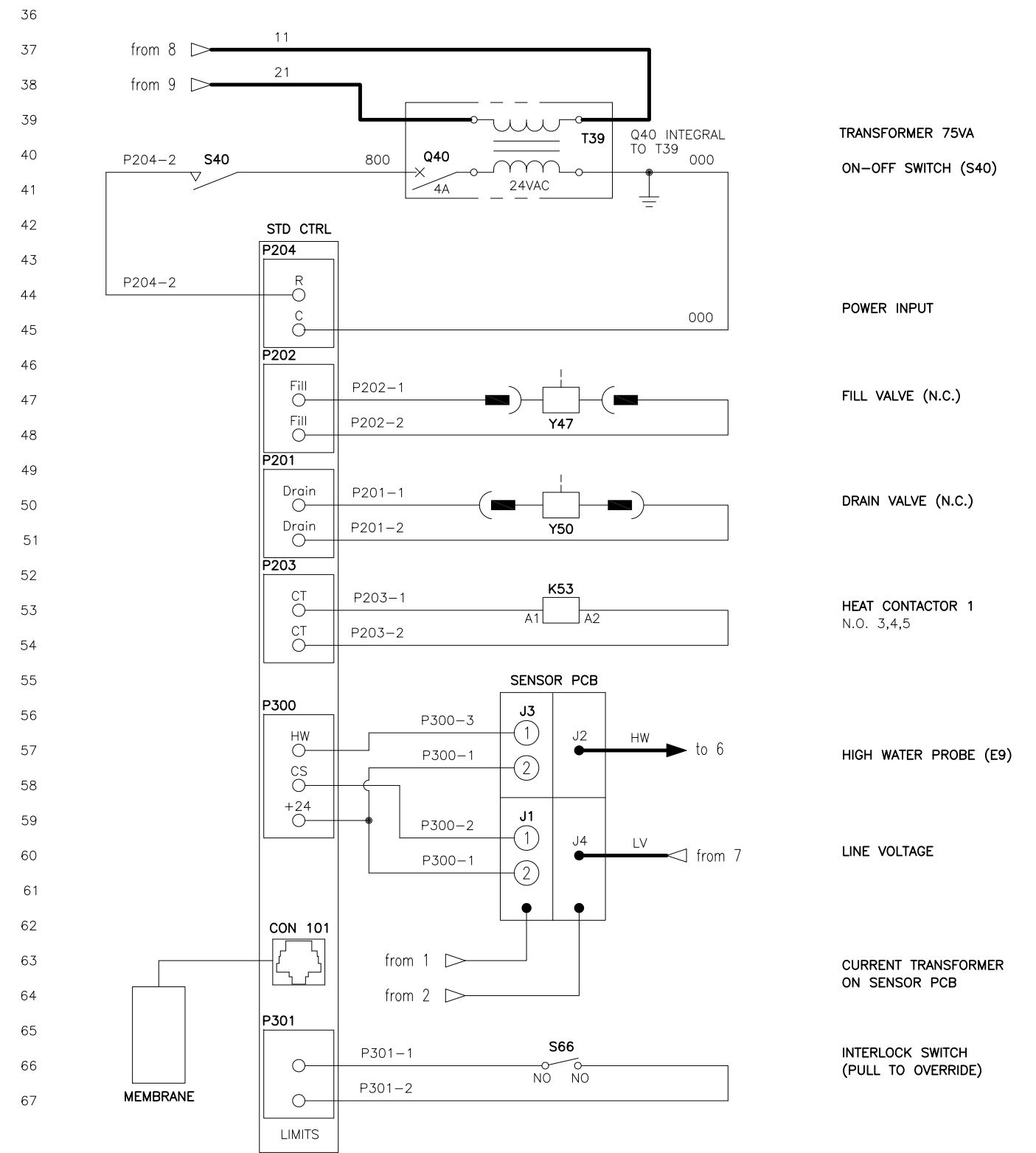
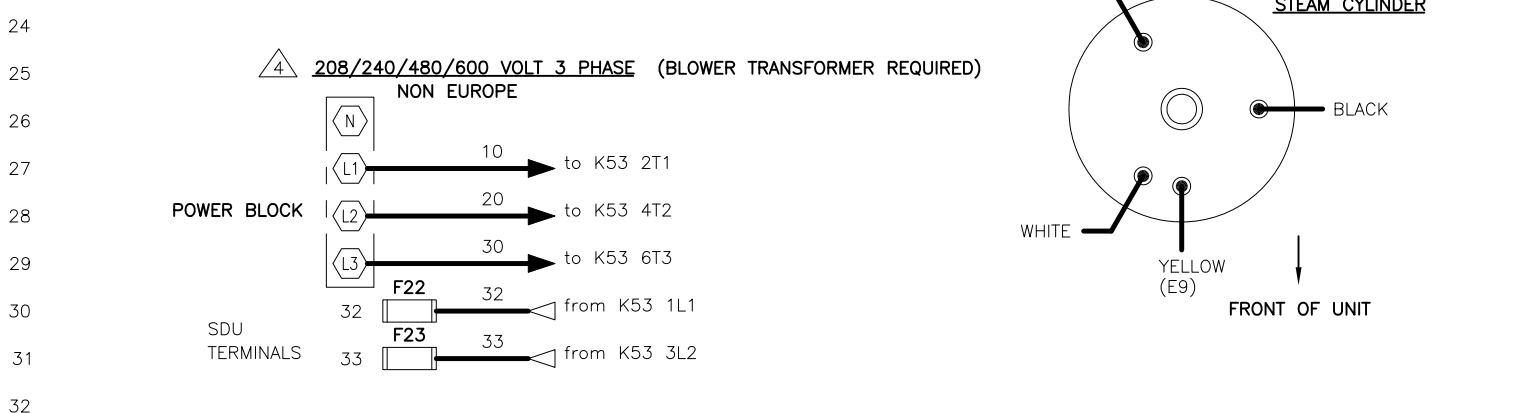
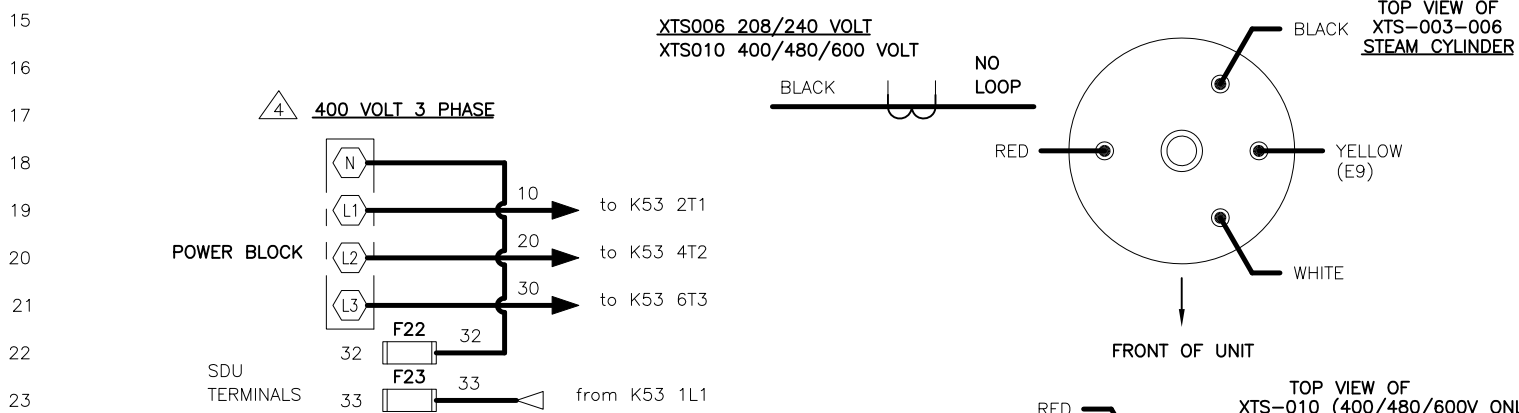
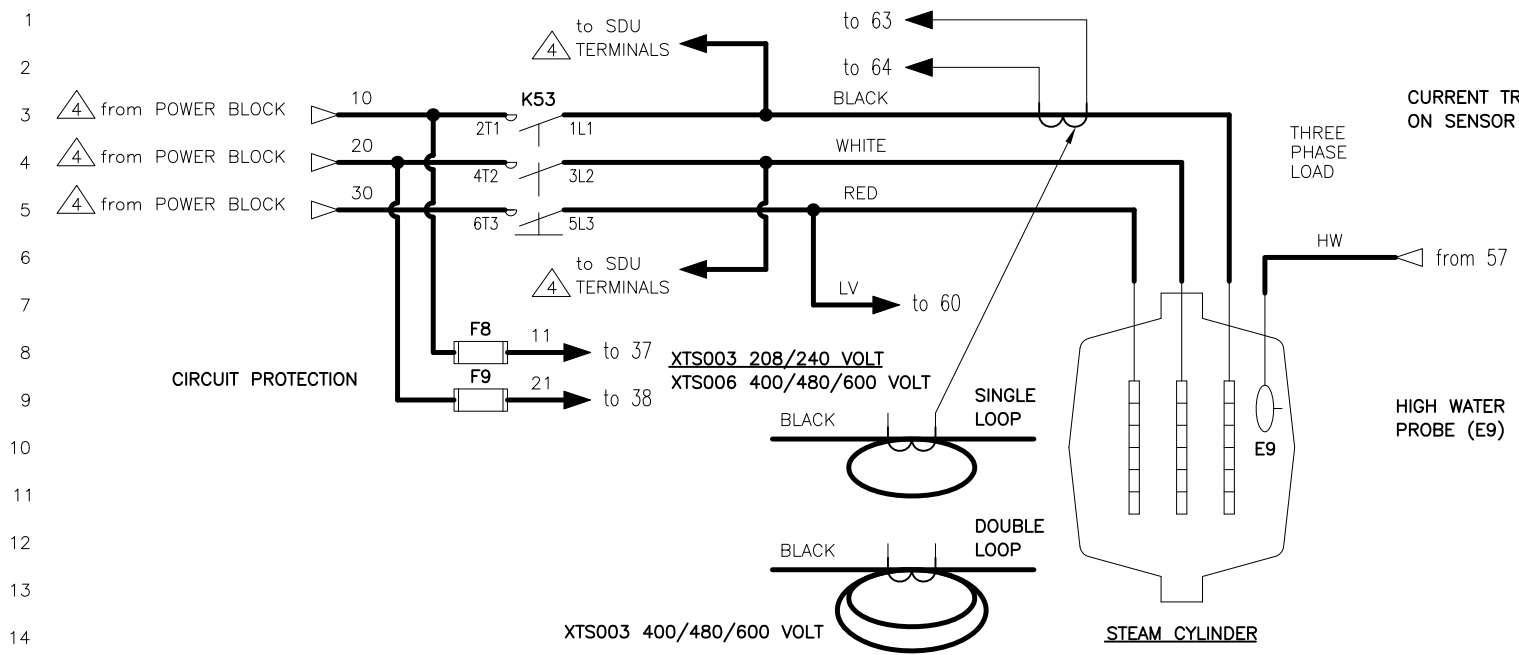

**POWER WIRING**  
 CONTROL CIRCUIT WIRING  
 FIELD WIRING  
 OPTIONAL FACTORY  
 OPTIONAL FIELD

**LEGEND**

K	RELAY/CONTACTOR	N	SOLENOID
T	TRANSFORMER	S	SENSOR
Q	CIRCUIT BREAKER	J	JUMPER
S	SWITCH	E	WATER PROBE
H	HEATER	M	MOTOR/FAN
F	FUSE		

- NOTES:**
1. WIRING AND BRANCH CIRCUIT PROTECTION PROVIDED BY INSTALLER AS PER NATIONAL ELECTRICAL CODE.
  2. FOR SUPPLY HEATER AND MACHINE GROUND CONNECTIONS, SIZE WIRE USING 75°C WIRE TABLE PER NATIONAL ELECTRICAL CODE.
  3. USE COPPER CONNECTORS RATED FOR 105°C.

4. SEE VOLTAGE SPECIFIC WIRING DETAIL.  
 5. REFER TO XTS ELECTRICAL DATA SHEET.

BREAK TO EXTERNAL CONNECTIONS DIAGRAM

		XTS THREE ELECTRODE	
		MAT'L:	P/N
SCALE:	DATE: 5/9/12	XTS-STD-2	
DRAWN BY: KROG			